



W55MID15



WINBOND MFID^{WB} TRANSPONDER

Table of Contents-

| | | |
|-------|-----------------------------------------------|---|
| 1. | GENERAL DESCRIPTION | 2 |
| 2. | FEATURES | 2 |
| 3. | PAD DESCRIPTION | 3 |
| 4. | BLOCK DIAGRAM | 3 |
| 5. | FUNCTIONAL DESCRIPTION..... | 4 |
| 5.1 | External Inductor Coupling Circuit..... | 4 |
| 5.2 | Voltage Regulator & System Power Supply | 4 |
| 5.3 | Power-On Control Circuit..... | 4 |
| 5.4 | Demodulation Control Circuit..... | 4 |
| 5.5 | System Clock Generator..... | 4 |
| 5.6 | Bonding-ID Decoder | 4 |
| 5.7 | Multiple Bonding-ID Arrays..... | 4 |
| 5.8 | Data Format and Framing Generator | 4 |
| 5.9 | Modulation Control Circuit | 4 |
| 6. | ELECTRICAL CHARACTERISTICS | 5 |
| 6.1 | Absolute Maximum Ratings..... | 5 |
| 6.2 | DC Characteristics..... | 5 |
| 7. | ORDERING INFORMATION..... | 5 |
| 8. | DESIGN INFORMATION | 6 |
| 8.1 | Reference Design | 6 |
| 8.1.1 | Demo Board..... | 6 |
| 9. | TYPICAL APPLICATION CIRCUIT | 6 |
| 10. | REVISION HISTORY | 7 |



1. GENERAL DESCRIPTION

MFID^{WB} (Magnetic Field Identification) is used in all areas of automatic data capture allowing contactless identification of objects using magnetic field. From ticketing to industrial automation and access control, the applications of MFID are burgeoning. In recent years automatic identification procedures have become very popular in many service industries, purchasing and distribution logistics, industry, manufacturing companies and material flow systems.

W55MID15 is one of Winbond *MFID^{WB}* (Magnetic Field Identification) series in *WinRF^{WB}* family that focus on toy and consumer related applications meanwhile W55MID15 provides manufacture bonding-ID transponder. Regarding the *MFID^{WB}* Reader series, the W55MID50 supports multi-functional *MFID^{WB}* Reader solution. Besides the single transponder application, W55MID35 offers multi-transponder recognition function for intelligent and smart toy applications.

W55MID15 provides total 243 different bonding-IDs in manufacture and 10bit ID length in each ID. That can extremely save customer's design investment in consumer MFID related products.

2. FEATURES

- Magnetic field resonance frequency: 13.56 MHz
- Data clock: 32 KHz
- Read-only bonding-ID transponder
- Inductive coupled power supply for no battery operation
- On-chip rectifier, voltage limiter, clock extraction
- 10bit bonding-ID length
- Provides Manchester coding data format
- RS0, RS1, RS2, RS3, and RS4 the 3-state bonding finger for the total 243 bonding-ID option in manufacture
- Low power, low voltage operation
- Operating distance: 0 ~ 5cm
- Operating temperature: 0 ~ 70 °C
- Package: Dice form
- Reference design PC board Size: 1.0 x 1.0cm² (with PCB antenna)
- Winbond patented "3-state Bonding Finger" for multiple bonding-ID option
- Minimize external component: capacitor and PCB antenna only



3. PAD DESCRIPTION

| SYMBOL | PAD NO. | I/O | FUNCTIONAL DESCRIPTION |
|--------|---------|--------|----------------------------------------------|
| NC | 1 | -- | Testing only, no connection |
| RS4 | 2 | I | 3-state bonding finger |
| RS3 | 3 | I | 3-state bonding finger |
| RS2 | 4 | I | 3-state bonding finger |
| RS1 | 5 | I | 3-state bonding finger |
| RS0 | 6 | I | 3-state bonding finger |
| Vss | 7 | Ground | Ground return path |
| COIL0 | 8 | I/O | Coupling energy input and customer-ID output |
| COIL1 | 9 | I/O | Coupling energy input and customer-ID output |
| NC | 10 | -- | Testing only, no connection |
| VDD | 11 | Power | Power path |

4. BLOCK DIAGRAM

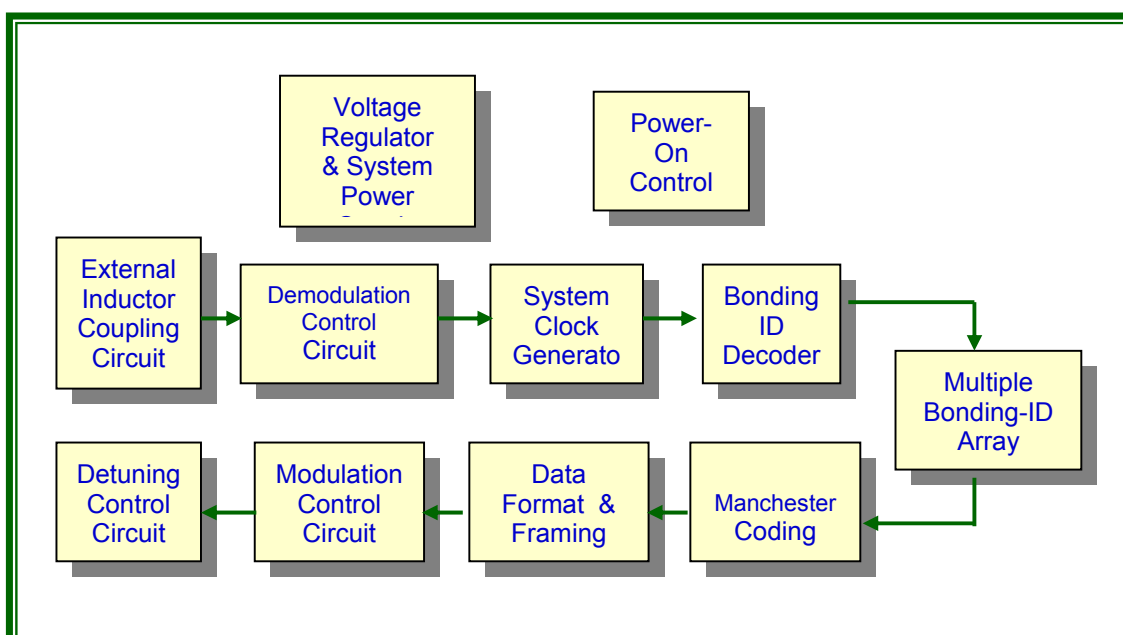



5. FUNCTIONAL DESCRIPTION

5.1 External Inductor Coupling Circuit

The external inductor coupling circuit is designed for 13.56MHz magnetic field resonance. The coupled center frequency will depend on equivalent inductor of external PCB inductor and a paralleled capacitor.

5.2 Voltage Regulator & System Power Supply

The voltage regulator generates the need of device power supply.

5.3 Power-On Control Circuit

System power-on control circuit initiates the device to get into initial state.

5.4 Demodulation Control Circuit

The demodulation control circuit demodulates the signal of command, which is magnetic field coupling from W55MID50 *MFID^{WB}* Reader system.

5.5 System Clock Generator

The system clock generator generates the need of device system clock.

5.6 Bonding-ID Decoder

The memory array decoder circuit decodes the mapping location of memory array, which indicates by external RS0, RS1, RS2, RS3, and RS4 the 3-state Bonding Finger (Winbond patented).

5.7 Multiple Bonding-ID Arrays

The multiple Bonding-IDs array provides total up to 243 different bonding-ID and 10bit in each ID.

5.8 Data Format and Framing Generator

The data format and framing generator is in charge of the entire bonding-ID and command data into a Winbond defined *MFID^{WB}* tag format.

5.9 Modulation Control Circuit

The modulation control circuit modulates the Winbond defined *MFID^{WB}* transponder format into the magnetic field resonance.

W55MID15



6. ELECTRICAL CHARACTERISTICS

6.1 Absolute Maximum Ratings

| PARAMETER | RATING | UNIT |
|-------------------------------|------------|------|
| Maximum Current in COIL | 10 | mA |
| Power Dissipation (TA = 70°C) | 100 | mW |
| Ambient Operating Temperature | 0 to +70 | °C |
| Storage Temperature | -40 to +85 | °C |

Note: Exposure to conditions beyond those listed under Absolute Maximum Ratings may adversely affect the life and reliability of the device.

6.2 DC Characteristics

(V_{DD} - V_{SS} = 4.5V, T_A = 25°C; unless otherwise specified)

| PARAMETER | SYM. | CONDITIONS | MIN. | TYP. | MAX. | UNIT |
|---------------------------|------------------|-----------------------------|------|-------|------|------|
| Operating Magnetic Field | f _{OP} | Field in resonation | - | 13.56 | - | MHz |
| Operating Voltage | V _{DD} | Field in resonation | 3 | - | 5.5 | V |
| Operating Temperature | T _{amb} | Ambient operating temp | 0 | 25 | 70 | °C |
| Operating Current | I _{OP} | f _{OP} = 13.56 MHz | - | 2 | - | μA |
| Magnetic Resonant Voltage | V _M | | 6 | - | 9 | V |

7. ORDERING INFORMATION

W55MID15 provides two types of package in shipment: Dice form & Wafer

| PART NUMBER | PACKAGE | REMARKS |
|-------------|------------|--------------|
| W55MID15 | Dice form | |
| W55MID15 | Wafer form | MOQ required |



8. DESIGN INFORMATION

8.1 Reference Design

This W55MID15 application schematic is subject to modify for target specification evaluation. Some components are due to system specification evaluation purpose only which will be removed once the system evaluation is done. The magnetic field coupling strength is subject to the appropriate value of inductor and capacitor.

8.1.1 Demo Board

$$f_{op} = \frac{1}{2\pi\sqrt{LC}} = 13.56\text{MH}$$

The value of "L" will depend on PCB coil layout and the value of "C" needs to fine-tune and matches the magnetic field resonance center $f_{OP} = 13.56\text{ MHz}$

9. TYPICAL APPLICATION CIRCUIT

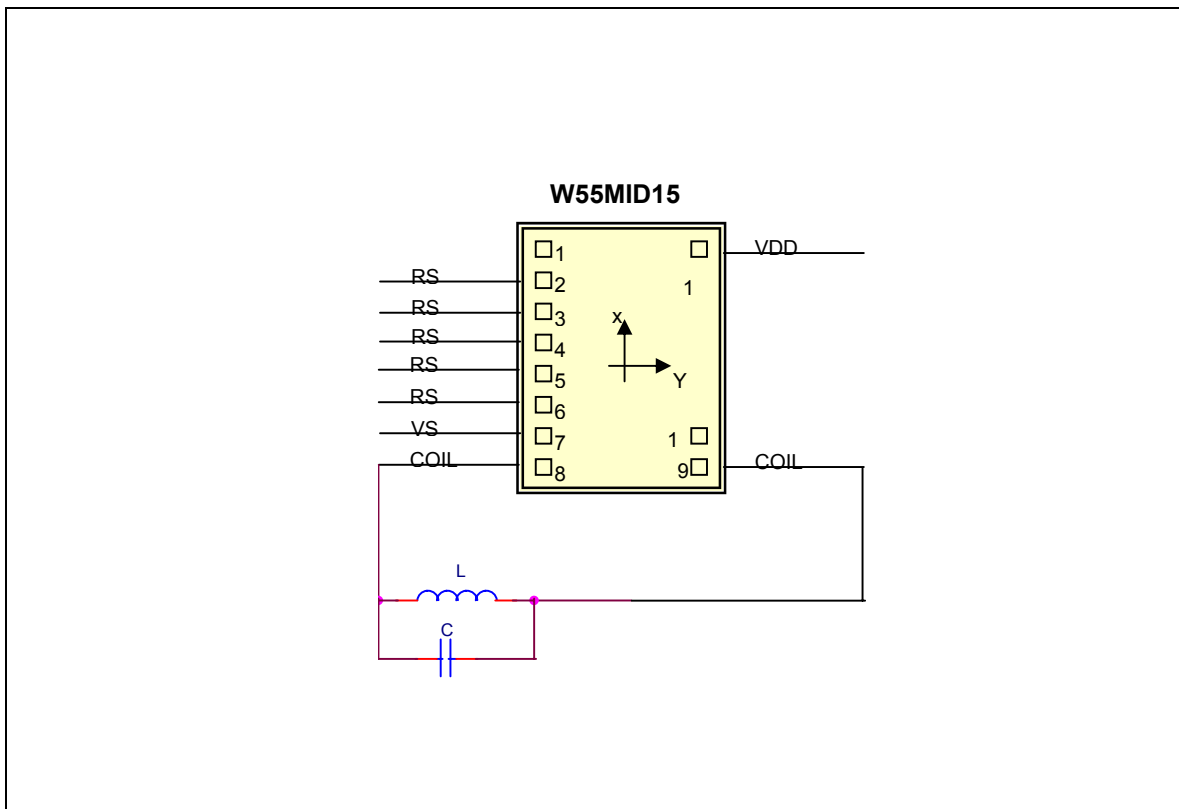



10. REVISION HISTORY

| VERSION | DATE | PAGE | DESCRIPTION |
|---------|----------------|------|-----------------------------------|
| A0 | Sep. 15, 2002 | - | Preliminary version |
| A1 | Dec. 29, 2002 | - | Pin functional description update |
| A2 | May 14, 2003 | - | Application schematic update |
| A3 | April 18, 2005 | 7 | ADD IMPORTANT NOTICE |

Important Notice

Winbond products are not designed, intended, authorized or warranted for use as components in systems or equipment intended for surgical implantation, atomic energy control instruments, airplane or spaceship instruments, transportation instruments, traffic signal instruments, combustion control instruments, or for other applications intended to support or sustain life. Further more, Winbond products are not intended for applications wherein failure of Winbond products could result or lead to a situation wherein personal injury, death or severe property or environmental damage could occur.

Winbond customers using or selling these products for use in such applications do so at their own risk and agree to fully indemnify Winbond for any damages resulting from such improper use or sales.



Headquarters
No. 4, Creation Rd. III,
Science-Based Industrial Park,
Hsinchu, Taiwan
TEL: 886-3-5770066
FAX: 886-3-5665577
<http://www.winbond.com.tw/>

Taipei Office
9F, No.480, Rueiguang Rd.,
Neihu District, Taipei, 114,
Taiwan, R.O.C.
TEL: 886-2-8177-7168
FAX: 886-2-8751-3579

Winbond Electronics Corporation America
2727 North First Street, San Jose,
CA 95134, U.S.A.
TEL: 1-408-9436666
FAX: 1-408-5441798

Winbond Electronics Corporation Japan
7F Daini-ueno BLDG, 3-7-18
Shinyokohama Kohoku-ku,
Yokohama, 222-0033
TEL: 81-45-4781881
FAX: 81-45-4781800

Winbond Electronics (Shanghai) Ltd.
27F, 2299 Yan An W. Rd. Shanghai,
200336 China
TEL: 86-21-62365999
FAX: 86-21-62365998

Winbond Electronics (H.K.) Ltd.
Unit 9-15, 22F, Millennium City,
No. 378 Kwun Tong Rd.,
Kowloon, Hong Kong
TEL: 852-27513100
FAX: 852-27552064

*Please note that all data and specifications are subject to change without notice.
All the trade marks of products and companies mentioned in this data sheet belong to their respective owners.*