

[查询W83195BR-101供应商](#)

[捷多邦，专业PCB打样工厂，24小时加急出货](#)



Winbond Clock Generator
W83195BR/G-101
For Intel 915/925 Chipsets

Date: March/10/2006 Revision: 0.7



W83195BR/G-101



STEPLESS FOR INTEL 915/925 CHIPSETS

W83195BR/G-101 Data Sheet Revision History

	Pages	Dates	Version	Web Version	Main Contents
1	n.a.	09/30/2004	0.5	n.a.	All of the versions before 0.5 are for internal use
2	6-11, 13	11/24/2004	0.6	n.a.	Correction IC version, add register default value and correction some description and default value
3	1-5, 7-15	3/10/2006	0.7	n.a.	Please see blue color text
4					
5					
6					
7					
8					
9					

Please note that all data and specifications are subject to change without notice. All the trademarks of products and companies mentioned in this data sheet belong to their respective owners.

LIFE SUPPORT APPLICATIONS

These products are not designed for use in life support appliances, devices, or systems where malfunction of these products can reasonably be expected to result in personal injury. Winbond customers using or selling these products for use in such applications do so at their own risk and agree to fully indemnify Winbond for any damages resulting from such improper use or sales.



STEPLESS FOR INTEL 915/925 CHIPSETS

Tables of Content-

1.	GENERAL DESCRIPTION	1
2.	PRODUCT FEATURES	1
3.	PIN CONFIGURATION	2
4.	BLOCK DIAGRAM	3
5.	PIN DESCRIPTION.....	4
5.1	Crystal I/O.....	4
5.2	CPU, SRC, PCIF, and PCI Clock Outputs	4
5.3	Frequency select, and Fixed Frequency Outputs.....	5
5.4	I2C Control Interface.....	5
5.5	Power Management Pins	6
5.6	Power Pins	6
6.	FREQUENCY SELECTION BY HARDWARE OR SOFTWARE	7
7.	I ² C CONTROL AND STATUS REGISTERS	8
7.1	Register 0: Frequency Select Register (Default = 10h).....	8
7.2	Register 1: CPU Clock Control (1 = Enable, 0 = Stopped) (Default: E7h).....	8
7.3	Register 2: PCI Clock Control (1 = Enable, 0 = Stopped) (Default: FFh)	9
7.4	Register 3: PCI Clock Control (1 = Enable, 0 = Stopped) (Default: FFh)	9
7.5	Register 4: 48MHz, DOT, REF Control (1 = Enable, 0 = Stopped) (Default: FFh).....	9
7.6	Register 5: Watchdog Control (Default: 02h).....	10
7.7	Register 6: SRC Control (1 = Enable, 0 = Stopped) (Default: FEh).....	10
7.8	Register 7: Winbond Chip ID (Default: 22h) (Read Only).....	10
7.9	Register 8: M/N Program (Default: D0h).....	11
7.10	Register 9: M/N Program Register (Default: 7Ah)	11
7.11	Register 10: Reserved (Default: 3Bh)	12
7.12	Register 11: Spread Spectrum Programming (Default: 0Bh).....	12
7.13	Register 12: Divisor Control (Default: 72h)	12
7.14	Register 13: Step-less Enable Control (Default: 0Fh)	13
7.15	Register 14: Control (Default: 10h).....	14
7.16	Register 15: Reserved (Default: ECh).....	14
7.17	Register 16: Skew Control (Default: E4h).....	14
7.18	Register 17: Reserved (Default: 00h).....	14
7.19	Register 18: Reserved (Default: 00h).....	14
7.20	Register 19: Reserved (Default: DAh).....	15



STEPLESS FOR INTEL 915/925 CHIPSETS

- 7.21 Register 20: Watch dog timer (Default: 88h)..... 15
- 7.22 Register21: Control (Default: 4Bh) 15
- 8. ACCESS INTERFACE 16
 - 8.1 Block Write protocol 16
 - 8.2 Block Read protocol..... 16
 - 8.3 Byte Write protocol..... 16
 - 8.4 Byte Read protocol 16
- 9. SPECIFICATIONS 17
 - 9.1 ABSOLUTE MAXIMUM RATINGS 17
 - 9.2 General Operating Characteristics 17
 - 9.3 Skew Group timing clock 18
 - 9.4 CPU 0.7V Electrical Characteristics 18
 - 9.5 SRC 0.7V Electrical Characteristics 18
 - 9.6 PCIF, PCI Electrical Characteristics 19
 - 9.7 48M Electrical Characteristics 19
 - 9.8 REF Electrical Characteristics 20
 - 9.9 DOT 0.7V Electrical Characteristics 20
- 10. ORDERING INFORMATION..... 21
- 11. HOW TO READ THE TOP MARKING 21
- 12. PACKAGE DRAWING AND DIMENSIONS..... 22

W83195BR/G-101



STEPLESS FOR INTEL 915/925 CHIPSETS

1. GENERAL DESCRIPTION

The W83195BR/G-101 is a Clock Synthesizer for Intel P4 processors and Intel Grandsdale chipsets. W83195BR/G-101 provides all clocks required for high-speed microprocessor and provides step-less frequency programming, 32 different frequencies of CPU, PCI, SRC clocks setting. Simultaneously W83194BR-101 supports SRC_SATA 100MHz clock output for SATA and DOT 96MHz clock outputs for integrated graphic chipsets. All clocks are externally selectable with smooth transitions.

The W83195BR/G-101 programs the registers to enable or disable each clock outputs through I²C serial bus interface and provides -0.5% down type spread spectrum or programmable spread spectrum scale to reduce EMI.

The W83195BR/G-101 is driven with a 14.318 MHz reference crystal and runs on a 3.3V supply.

2. PRODUCT FEATURES

- 2 pair 0.7 V current mode Differential clock outputs for CPU
- 6 pair 0.7V current mode Differential clock outputs for SRC and SRC_SATA.
- 1 pair 0.7V current mode Differential 96MHz clock outputs for DOT.
- 6 PCI clock outputs for PCI
- 3 PCI clock free running outputs for PCI
- 1 48 MHz clock output for USB.
- 1 14.318MHz REF clock outputs.
- Step-less frequency programming
- I²C 2-Wire serial interface and support byte read/write and block read/write.
- -0.5% down type spread spectrum in H/W and software select mode.
- Programmable S.S.T. scale to reduce EMI in M/N mode.
- Programmable registers to enable/stop each output.
- Programmable clock outputs to control skew.
- Watch Dog Timer output
- 56 pin SSOP package

W83195BR/G-101



STEPLESS FOR INTEL 915/925 CHIPSETS

3. PIN CONFIGURATION

VDDPCI	1	●	56	PCI2
GND	2		55	PCI1
PCI3	3		54	PCI0/ [♠] FS_4
PCI4	4		53	*FS_2
PCI5	5		52	REF0/ [♠] FS_3
GND	6		51	GND
VDDPCI	7		50	XIN
PCICLK_F0	8		49	XOUT
PCICLK_F1	9		48	VDDREF
PCICLK_F2	10		47	*SDATA
VDD48	11		46	*SCLK
48MHZ	12		45	GND
GND	13		44	CPUCLKT0
DOTT_96MHZ	14		43	CPUCLKC0
DOTC_96MHZ	15		42	VDDCPU
*FS_1	16		41	CPUCLKT1
Vtt_PWRGd#/PD	17		40	CPUCLKC1
*FS_0	18		39	IREF
SRCT1	19		38	GND
SRCC1	20		37	VDDA
VDDSRC	21		36	SRCT7
SRCT2	22		35	SRCC7
SRCC2	23		34	VDDSRC
SRCT3	24		33	SRCT6
SRCC3	25		32	SRCC6
SRCT4_SATA	26		31	SRCT5
SRCC4_SATA	27		30	SRCC5
VDDSRC	28		29	GND

#: Active low

*: Internal pull up resistor 120KΩ to VDD

&: Internal Pull-down resistor 120KΩ to GND



STEPLESS FOR INTEL 915/925 CHIPSETS

4. BLOCK DIAGRAM

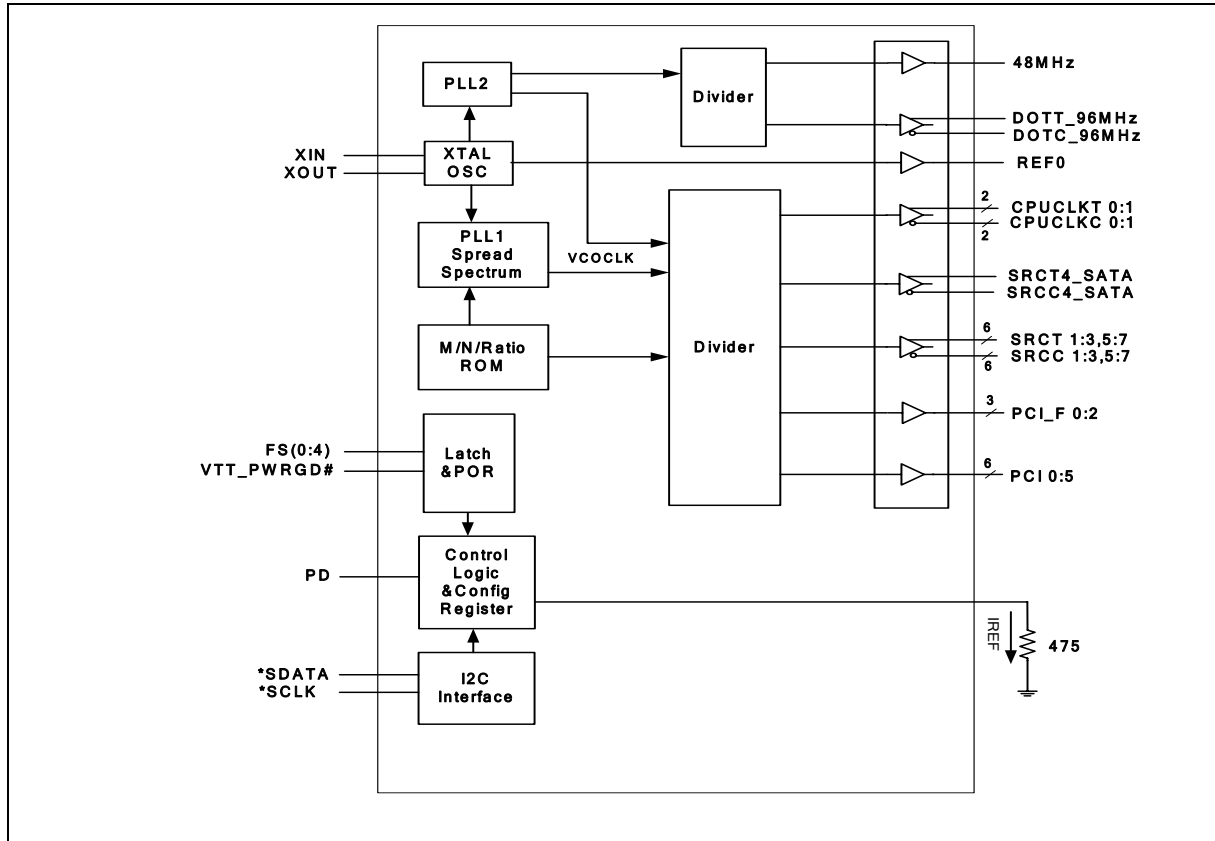



STEPLESS FOR INTEL 915/925 CHIPSETS

5. PIN DESCRIPTION

BUFFER TYPE SYMBOL	DESCRIPTION
IN	Input
IN _{tp120k}	Latched input at power up, internal 120kΩ pull up.
IN _{td120k}	Latched input at power up, internal 120kΩ pull down.
OUT	Output
I/OD	Bi-directional Pin, Open Drain.
#	Active Low
*	Internal 120kΩ pull-up
&	Internal 120kΩ pull-down

5.1 Crystal I/O

PIN	PIN NAME	TYPE	DESCRIPTION
50	XIN	IN	Crystal input with internal loading capacitors (18pF) and feedback resistors.
49	XOUT	OUT	Crystal output at 14.318MHz nominally with internal loading capacitors (18pF).

5.2 CPU, SRC, PCIF, and PCI Clock Outputs

PIN	PIN NAME	TYPE	DESCRIPTION
44,43,41,40	CPUT [0:1] CPUC [0:1]	OUT	Low skew (< 125ps) 0.7V current mode differential clock outputs for host frequencies of CPU
19,20,22,23,24,25,31,30,33,32,36,35	SRCT[1:3,5:7] SRCC[1:3,5:7]	OUT	Low skew (<125ps)0.7V current mode differential clock outputs for PCI-E
8,9,10	PCI_F[0:2]	OUT	3.3V free running PCI clock output.
54	PCI0	OUT	3.3V PCI clock output.
	&FS4	IN _{td120k}	Latched input for FS4 at initial power up for H/W selecting the output frequency. Latched voltage level refers to Vil_FS and Vih_FS voltage level. This is internal 120K pull down.
55,56,3,4,5	PCI [1:5]	OUT	Low skew (< 500ps) 3.3V PCI clock outputs



STEPLESS FOR INTEL 915/925 CHIPSETS

5.3 Frequency select, and Fixed Frequency Outputs

PIN	PIN NAME	TYPE	DESCRIPTION
18	*FS0	IN _{tp120k}	Latched input for FS0 at initial power up for H/W selecting the output frequency. Latched voltage level refers to Vil_FS and Vih_FS voltage level. This is internal 120K pull up.
16	*FS1	IN _{tp120k}	Latched input for FS1 at initial power up for H/W selecting the output frequency. Latched voltage level refers to Vil_FS and Vih_FS voltage level. This is internal 120K pull up.
53	*FS2	IN _{tp120k}	Latched input for FS2 at initial power up for H/W selecting the output frequency. Latched voltage level refers to Vil_FS and Vih_FS voltage level. This is internal 120K pull up.
52	REF0	OUT	3.3V REF0 14.318MHz clock output.
	&FS3	IN _{td120k}	Latched input for FS3 at initial power up for H/W selecting the output frequency. Latched voltage level refers to Vil_FS and Vih_FS voltage level. This is internal 120K pull down.
12	48MHz	OUT	48MHz clock output for USB.
14,15	DOTT/C_96MHz	OUT	0.7V current mode 96MHz differential clock outputs for DOT
26,27	SRCT/C4_SATA	OUT	0.7V current mode 100MHz differential clock outputs for SATA

5.4 I2C Control Interface

PIN	PIN NAME	TYPE	DESCRIPTION
47	*SDATA	I/OD	Serial data of I ² C 2-wire control interface with internal pull-up resistor.
46	*SCLK	IN	Serial clock of I ² C 2-wire control interface with internal pull-up resistor.



STEPLESS FOR INTEL 915/925 CHIPSETS

5.5 Power Management Pins

PIN	PIN NAME	TYPE	DESCRIPTION
39	IREF	OUT	Deciding the reference current for the differential pairs. The pin was connected to the precision resistor tied to ground to decide the appropriate current; 475 ohm is the standard value.
17	VTT_PWRGD#	IN	Power good is a low active input signal used to determine when FS [4:0] are valid to be sample.
	PD	IN _{td120k}	Power Down Function. This is power down pin, high active (PD). Internal 120K pull down

5.6 Power Pins

PIN	PIN NAME	TYPE	DESCRIPTION
37	VDDA	PWR	3.3V power supply for PLL core.
1,7	VDDP	PWR	3.3V power supply for PCI.
21,28,34	VDDS	PWR	3.3V power supply for SRC pair.
11	VDD48	PWR	3.3V power supply for 48MHz.
42	VDDC	PWR	3.3V power supply for CPU.
48	VDDR	PWR	3.3V power supply for REF.
38	GNDA	PWR	Ground pin for PLL core.
2,6,13,29,45,51	GND	PWR	Ground pin

W83195BR/G-101



STEPLESS FOR INTEL 915/925 CHIPSETS

6. FREQUENCY SELECTION BY HARDWARE OR SOFTWARE

This frequency table is used at power on latched FS [4:0] value or software programming at SSEL [4:0] (Register 0 bit 7 ~ 3).

FS4	FS3	FS2	FS1	FS0	CPU (MHZ)	DOT (MHZ)	SRC (MHZ)	PCI (MHZ)
0	0	0	0	0	266.66	96.00	100.00	33.34
0	0	0	0	1	133.33	96.00	100.00	33.34
0	0	0	1	0	200.00	96.00	100.00	33.34
0	0	0	1	1	166.66	96.00	100.00	33.34
0	0	1	0	0	333.33	96.00	100.00	33.34
0	0	1	0	1	100.00	96.00	100.00	33.34
0	0	1	1	0	400.00	96.00	100.00	33.34
0	0	1	1	1	200.00	96.00	100.00	33.34
0	1	0	0	0	266.66	96.00	100.00	33.34
0	1	0	0	1	133.33	96.00	100.00	33.34
0	1	0	1	0	200.00	96.00	100.00	33.34
0	1	0	1	1	166.66	96.00	100.00	33.34
0	1	1	0	0	333.33	96.00	100.00	33.34
0	1	1	0	1	100.00	96.00	100.00	33.34
0	1	1	1	0	400.00	96.00	100.00	33.34
0	1	1	1	1	200.00	96.00	100.00	33.34
1	0	0	0	0	269.33	96.00	100.00	33.34
1	0	0	0	1	134.66	96.00	100.00	33.34
1	0	0	1	0	202.00	96.00	100.00	33.34
1	0	0	1	1	168.33	96.00	100.00	33.34
1	0	1	0	0	274.66	96.00	100.00	33.34
1	0	1	0	1	137.33	96.00	100.00	33.34
1	0	1	1	0	206.00	96.00	100.00	33.34
1	0	1	1	1	171.66	96.00	100.00	33.34
1	1	0	0	0	279.99	96.00	100.00	33.34
1	1	0	0	1	140.00	96.00	100.00	33.34
1	1	0	1	0	210.00	96.00	100.00	33.34
1	1	0	1	1	174.99	96.00	100.00	33.34
1	1	1	0	0	287.99	96.00	100.00	33.34
1	1	1	0	1	144.00	96.00	100.00	33.34
1	1	1	1	0	216.00	96.00	100.00	33.34
1	1	1	1	1	179.99	96.00	100.00	33.34



STEPLESS FOR INTEL 915/925 CHIPSETS

7. I²C CONTROL AND STATUS REGISTERS

7.1 Register 0: Frequency Select Register (Default = 10h)

BIT	NAME	PWD	DESCRIPTION	TYPE
7	SSEL [4]	0	Frequency selection by software via I ² C	R/W
6	SSEL [3]	0		
5	SSEL [2]	0		
4	SSEL [1]	1		
3	SSEL [0]	0		
2	EN_SSEL	0	Enable software frequency table selection SSEL [4:0]. 0 = Select frequency by hardware. 1 = Select frequency by software I ² C - Bit 7~ 3.	R/W
1	SPSPEN	0	Enable Spread Spectrum 0 = Normal 1 = Spread Spectrum enabled	R/W
0	EN_SAFE_FREQ	0	Enable reload safe frequency when the watchdog is timeout. 0 = reload the FS [2:0] latched pins when watchdog time out. 1 = reload the safe frequency bit defined at Register 5 bit 4~0.	R/W

7.2 Register 1: CPU Clock Control (1 = Enable, 0 = Stopped) (Default: E7h)

BIT	PIN NO	PWD	DESCRIPTION	TYPE
7	36,35	1	SRC7 output control	R/W
6	41,40	1	CPUT1 / C1 output control	R/W
5	44,43	1	CPUT0 / C0 output control	R/W
4	-	X	Power on latched value of FS4 pin, Default: 0 (Read only).	R
3	-	X	Power on latched value of FS3 pin, Default: 0 (Read only).	R
2	-	X	Power on latched value of FS2 pin, Default: 1 (Read only).	R
1	-	X	Power on latched value of FS1 pin, Default: 1 (Read only).	R
0	-	X	Power on latched value of FS0 pin, Default: 1 (Read only).	R



STEPLESS FOR INTEL 915/925 CHIPSETS

7.3 Register 2: PCI Clock Control (1 = Enable, 0 = Stopped) (Default: FFh)

BIT	PIN NO	PWD	DESCRIPTION	TYPE
7	Reserved	1	Reserved	R/W
6	9,10	1	PCI_F1/PCI_F2 output control	R/W
5	8	1	PCI_F0 output control	R/W
4	Reserved	1	Reserved	R/W
3	Reserved	1	Reserved	R/W
2	5	1	PCI5 output control	R/W
1	Reserved	1	Reserved	R/W
0	3,4	1	PCI3, PCI4 output control	R/W

7.4 Register 3: PCI Clock Control (1 = Enable, 0 = Stopped) (Default: FFh)

BIT	PIN NO	PWD	DESCRIPTION	TYPE
7	56	1	PCI2 output control	R/W
6	55	1	PCI1 output control	R/W
5	54	1	PCI0 output control	R/W
4	Reserved	1	Reserved	R/W
3	Reserved	1	Reserved	R/W
2	Reserved	1	Reserved	R/W
1	Reserved	1	Reserved	R/W
0	Reserved	1	Reserved	R/W

7.5 Register 4: 48MHz, DOT, REF Control (1 = Enable, 0 = Stopped) (Default: FFh)

BIT	PIN NO	PWD	DESCRIPTION	TYPE
7	Reserved	1	Reserved	R/W
6	14,15	1	DOT_T/C 96MHz output control	R/W
5	12	1	48MHz output control	R/W
4	Reserved	1	Reserved	R/W
3	Reserved	1	Reserved	R/W
2	52	1	REF0 output control	R/W
1	Reserved	1	Reserved	R/W
0	Reserved	1	Reserved	R/W



STEPLESS FOR INTEL 915/925 CHIPSETS

7.6 Register 5: Watchdog Control (Default: 02h)

BIT	NAME	PWD	DESCRIPTION	TYPE
7	Reserved	X	Reserved	R/W
6	EN_WD	0	Program this bit => 1: Enable Watchdog Timer feature. 0: Disable Watchdog Timer feature. Read-back this bit => During timer count down the bit read back to 1. If count to zero, this bit read back to 0.	R/W
5	WD_TIMEOUT	0	Read Back only. Timeout Flag. This bit is Read Only. 1: Watchdog has ever started and counts to zero. 0: Watchdog is restarted and counting.	R
4	SAF_FREQ [4]	0	These bits will be reloaded in Reg-0 to select frequency table. As the watchdog is timeout and EN_SAFE_FREQ=1.	R/W
3	SAF_FREQ [3]	0		
2	SAF_FREQ [2]	0		
1	SAF_FREQ [1]	1		
0	SAF_FREQ [0]	0		

7.7 Register 6: SRC Control (1 = Enable, 0 = Stopped) (Default: FEh)

BIT	NAME	PWD	DESCRIPTION	TYPE
7	Reserved	1	Reserved	R/W
6	33,32	1	SRCT/C 6 outputs control	R/W
5	31,30	1	SRCT/C 5 outputs control	R/W
4	26,27	1	SRCT/C 4_SATA outputs control	R/W
3	24,25	1	SRCT/C 3 outputs control	R/W
2	22,23	1	SRCT/C 2 outputs control	R/W
1	19,20	1	SRCT/C 1 outputs control	R/W
0	Reserved	0	Reserved	R/W

7.8 Register 7: Winbond Chip ID (Default: 22h) (Read Only)

BIT	NAME	PWD	DESCRIPTION	TYPE
7	CHPI_ID [7]	0	Winbond Chip ID. W83195BR/G-101	R
6	CHPI_ID [6]	0	Winbond Chip ID.	R
5	CHPI_ID [5]	1	Winbond Chip ID.	R



STEPLESS FOR INTEL 915/925 CHIPSETS

Register 7: Winbond Chip ID (Default: 22h) (Read Only), continued

BIT	NAME	PWD	DESCRIPTION	TYPE
4	CHPI_ID [4]	0	Winbond Chip ID.	R
3	CHPI_ID [3]	0	Winbond Chip ID.	R
2	CHPI_ID [2]	0	Winbond Chip ID.	R
1	CHPI_ID [1]	1	Winbond Chip ID.	R
0	CHPI_ID [0]	0	Winbond Chip ID.	R

7.9 Register 8: M/N Program (Default: D0h)

BIT	NAME	PWD	DESCRIPTION	TYPE
7	N_DIV [8]	1	Programmable N divisor value. Bit7~0 are defined in the Register 9	R/W
6	N_DIV [9]	1	Programmable N divisor value. Bit7~0 are defined in the Register 9	R/W
5	M_DIV [5]	0	Programmable M divisor value.	R/W
4	M_DIV [4]	1		R/W
3	M_DIV [3]	0		R/W
2	M_DIV [2]	0		R/W
1	M_DIV [1]	0		R/W
0	M_DIV [0]	0		R/W

7.10 Register 9: M/N Program Register (Default: 7Ah)

BIT	NAME	PWD	DESCRIPTION	TYPE
7	N_DIV [7]	0	Programmable N divisor value bit 7 ~0. The bit 8 is defined in Register 8.	R/W
6	N_DIV [6]	1		R/W
5	N_DIV [5]	1		R/W
4	N_DIV [4]	1		R/W
3	N_DIV [3]	1		R/W
2	N_DIV [2]	0		R/W
1	N_DIV [1]	1		R/W
0	N_DIV [0]	0		R/W

W83195BR/G-101



STEPLESS FOR INTEL 915/925 CHIPSETS

7.11 Register 10: Reserved (Default: 3Bh)

BIT	NAME	PWD	DESCRIPTION	TYPE
7	SRC_SPSPEN	0	Enable SRC spread spectrum feature, 1: Enable, 0: Disable	R/W
6	N3VAL<6>	0	Programmable N3 divisor 6~0 for programmable SATA clock.	R/W
5	N3VAL<5>	1		R/W
4	N3VAL<4>	1		R/W
3	N3VAL<3>	1		R/W
2	N3VAL<2>	0		R/W
1	N3VAL<1>	1		R/W
0	N3VAL<0>	1		R/W

7.12 Register 11: Spread Spectrum Programming (Default: 0Bh)

BIT	NAME	PWD	DESCRIPTION	TYPE
7	SP_UP [3]	0	Spread Spectrum Up Counter bit 3 ~ bit 0.	R/W
6	SP_UP [2]	0		R/W
5	SP_UP [1]	0		R/W
4	SP_UP [0]	0		R/W
3	SP_DOWN [3]	1	Spread Spectrum Down Counter bit 3 ~ bit 0 2's complement representation. Ex: 1 -> 1111; 2 -> 1110; 7 -> 1001; 8 -> 1000	R/W
2	SP_DOWN [2]	0		R/W
1	SP_DOWN [1]	1		R/W
0	SP_DOWN [0]	1		R/W

7.13 Register 12: Divisor Control (Default: 72h)

BIT	NAME	PWD	DESCRIPTION	TYPE
7	Reserved	0	Reserved	R/W
6	KVAL6	X	Reserved	R/W
5	KVAL5	X		R/W
4	KVAL4	X	Reserved	R/W
3	KVAL3	X		R/W
2	KVAL2	X	Define the CPU divider ratio Refer to Table-2	R/W
1	KVAL1	X		R/W
0	KVAL0	X		R/W



STEPLESS FOR INTEL 915/925 CHIPSETS

Table-2 CPU, SRC, PCI divider ratio selection Table

LSB		CPU			
		Bit1, 0			
MSB		00	01	10	11
Bit2/ Bit4/ Bit6	0	Div2	Div3	Div4	Div6
	1	Div0	Div0	Div0	Div0

7.14 Register 13: Step-less Enable Control (Default: 0Fh)

BIT	NAME	PWD	DESCRIPTION	TYPE
7	EN_MN_PROG	0	0: Output frequency depend on frequency table 1: Program all clock frequency by changing M/N value The equation is $VCO = 14.318MHz * (N+4) / M$ Once the watchdog timer timeout, the bit will be clear. Then the frequency will be decided by hardware default FS<2:0> or desired frequency select SAF_FREQ [4:0] depend on EN_SAFE_FREQ (Reg0 - bit 0).	R/W
6	N<10>	0	Programmable N divisor bit 10.	R/W
5	Reserved	0	Reserved	R/W
4	Reserved	0	Reserved	R/W
3	IVAL<3>	1	Charge pump current selection	R/W
2	IVAL<2>	1		R/W
1	IVAL<1>	1		R/W
0	IVAL<0>	1		R/W



STEPLESS FOR INTEL 915/925 CHIPSETS

7.15 Register 14: Control (Default: 10h)

BIT	NAME	PWD	DESCRIPTION	TYPE
7	DRI_CONT	0	CPUT / SRCT / DOT_T output state in during POWER DOWN assertion. 1: Driven (2*Iref), 0: Tristate (Floating) CPUT / SRCT / DOT_T output state in during STOP Mode assertion. 1: Driven (6*Iref), 0: Tristate (Floating) Complementary parts always tri-state (floating) in power down or stop mode.	R/W
6	Reserved	0	Reserved	R/W
5	SPCNT [5]	0	Spread Spectrum Programmable time, the resolution is 280ns. Default period is 11.8us	R/W
4	SPCNT [4]	1		R/W
3	SPCNT [3]	0		R/W
2	SPCNT [2]	0		R/W
1	SPCNT [1]	0		R/W
0	SPCNT [0]	0		R/W

7.16 Register 15: Reserved (Default: ECh)

7.17 Register 16: Skew Control (Default: E4h)

BIT	NAME	PWD	DESCRIPTION	TYPE
7	Reserved	1	Reserved	R/W
6	Reserved	1	Reserved	R/W
5	Reserved	1	Reserved	R/W
4	Reserved	0		R/W
3	Reserved	0		R/W
2	PSKEW [2]	1	CPU1 to PCI skew control, Skew resolution is 300ps	R/W
1	PSKEW [1]	0	The decision of skew direction is same as PSKEW [2:0] setting	R/W
0	PSKEW [0]	0		R/W

7.18 Register 17: Reserved (Default: 00h)

7.19 Register 18: Reserved (Default: 00h)



STEPLESS FOR INTEL 915/925 CHIPSETS

7.20 Register 19: Reserved (Default: DAh)

7.21 Register 20: Watch dog timer (Default: 88h)

BIT	NAME	PWD	DESCRIPTION	TYPE
7	Reserved	1	Reserved	R/W
6	WD_TIME [6]	0	Setting the down count depth (Failure decision). One bit resolution represents 250ms. Default time depth is 8*250ms = 2.0 second. If the watchdog timer is counting, this register will return present down count value.	R/W
5	WD_TIME [5]	0		R/W
4	WD_TIME [4]	0		R/W
3	WD_TIME [3]	1		R/W
2	WD_TIME [2]	0		R/W
1	WD_TIME [1]	0		R/W
0	WD_TIME [0]	0		R/W

7.22 Register21: Control (Default: 4Bh)

BIT	NAME	PWD	DESCRIPTION	TYPE
7	Tri-state	0	Tri-state all output if set 1	R/W
6	Reserved	1	Reserved	R/W
5	Reserved	0	Reserved	R/W
4	Reserved	0	Reserved	R/W
3	Reserved	1	Reserved	R/W
2	Reserved	0	Reserved	R/W
1	Reserved	1	Reserved	R/W
0	Reserved	1	Reserved	R/W



STEPLESS FOR INTEL 915/925 CHIPSETS

8. ACCESS INTERFACE

The W83195BR/G-101 provides I²C Serial Bus for microprocessor to read/write internal registers. In the W83195BR/G-101 is provided Block Read/Block Write and Byte-Data Read/Write protocol. The I²C address is defined at 0xD2.

Block Read and Block Write Protocol

8.1 Block Write protocol

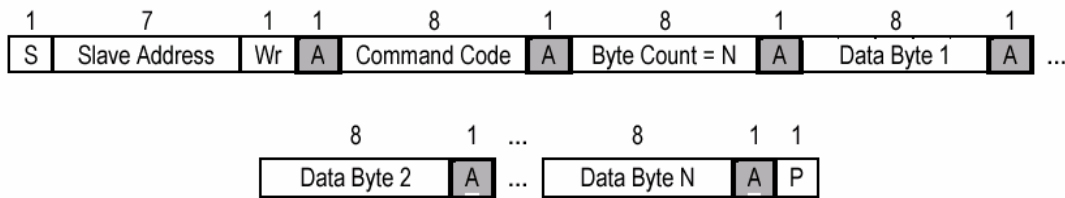

8.2 Block Read protocol

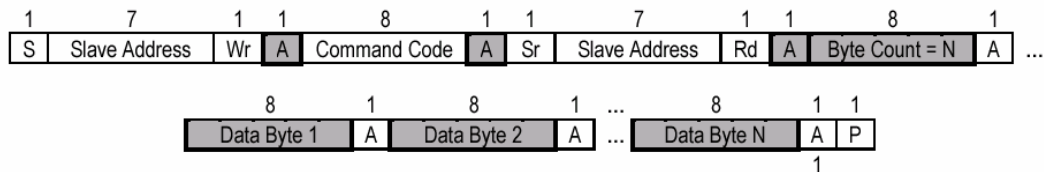

In block mode, the command code must filled 8'h00

8.3 Byte Write protocol

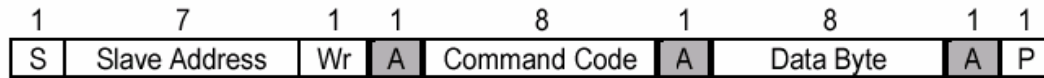

8.4 Byte Read protocol

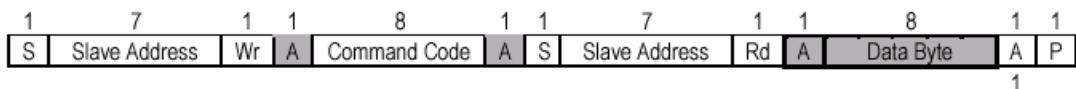

PS: In byte Mode program register Byte number is datasheet register Byte number+1



STEPLESS FOR INTEL 915/925 CHIPSETS

9. SPECIFICATIONS

9.1 ABSOLUTE MAXIMUM RATINGS

Stresses greater than those listed in this table may cause permanent damage to the device. Precautions should be taken to avoid application of any voltage higher than the maximum rated voltages to this circuit. Subjection to maximum conditions for extended periods may affect reliability. Unused inputs must always be tied to an appropriate logic voltage level (Ground or VDD).

Parameter	Rating
Absolute 3.3V Core Supply Voltage	-0.5V to +4.6V
Absolute 3.3V I/O Supply Voltage	- 0.5V to + 4.6V
Operating 3.3V Core Supply Voltage	3.135V to 3.465V
Operating 3.3V I/O Supply Voltage	3.135V to 3.465V
Storage Temperature	- 65°C to + 150°C
Ambient Temperature	- 55°C to + 125°C
Operating Temperature	0°C to + 70°C
Input ESD protection (Human body model)	2000V

9.2 General Operating Characteristics

<i>VDD= 3.3V ± 5 %, TA = 0°C to +70°C,</i>					
Parameter	Symbol	Min	Max	Units	Test Conditions
Input Low Voltage	V _{IL}		0.8	V _{dc}	
Input High Voltage	V _{IH}	2.0		V _{dc}	
Output Low Voltage	V _{OL}		0.4	V _{dc}	
Output High Voltage	V _{OH}	2.4		V _{dc}	
Operating Supply Current	I _{dd}		350	mA	CPU = 100 to 400 MHz PCI = 33.3 Mhz with load 10pF
Input pin capacitance	C _{in}		5	pF	
Output pin capacitance	C _{out}		6	pF	
Input pin inductance	L _{in}		7	nH	



STEPLESS FOR INTEL 915/925 CHIPSETS

9.3 Skew Group timing clock

<i>VDD = 3.3V ± 5 %, TA = 0°C to +70°C, Cl=10pF</i>				
Parameter	Min	Max	Units	Test Conditions
CPU pair to CPU pair Skew		125	ps	Measure Crossing point
SRC pair to SRC pair Skew		125	ps	Measure Crossing point
PCI to PCI Skew		500	ps	Measured at 1.5V

9.4 CPU 0.7V Electrical Characteristics

<i>VDDC= 3.3V ± 5 %, TA = 0°C to +70°C, Test load Rs=33, Rp=49.9 Cl=2pF, Vol=0.175V, Voh=0.525V, Vr=475, IREF=2.32mA, loh=6*IREF</i>				
Parameter	Min	Max	Units	Test Conditions
Rise Time	175	700	ps	Measure Single Ended waveform
Fall Time	175	700	ps	Measure Single Ended waveform
Absolute crossing point Voltages	250	550	mV	Measure Single Ended waveform
Voltage High	660	850	mV	Measure Single Ended waveform
Voltage Low	-150		mV	Measure Single Ended waveform
Cycle to Cycle jitter		100	ps	Measure Differential waveform
Duty Cycle	45	55	%	Measure Differential waveform

9.5 SRC 0.7V Electrical Characteristics

<i>VDDs= 3.3V ± 5 %, TA = 0°C to +70°C, Test load Rs=33, Rp=49.9 Cl=2pF, Vol=0.175V, Voh=0.525V, Vr=475, IREF=2.32mA, loh=6*IREF</i>				
Parameter	Min	Max	Units	Test Conditions
Rise Time	175	700	ps	Measure Single Ended waveform
Fall Time	175	700	ps	Measure Single Ended waveform
Absolute crossing point Voltages	250	550	mV	Measure Single Ended waveform
Voltage High	660	850	mV	Measure Single Ended waveform
Voltage Low	-150		mV	Measure Single Ended waveform
Cycle to Cycle jitter		125	ps	Measure Differential waveform
Duty Cycle	45	55	%	Measure Differential waveform



STEPLESS FOR INTEL 915/925 CHIPSETS

9.6 PCIF, PCI Electrical Characteristics

<i>VDDP= 3.3V ± 5 %, TA = 0°C to +70°C, Test load, CI=10pF,</i>				
Parameter	Min	Max	Units	Test Conditions
Rise Time	500	2000	ps	Vol=0.4V, Voh=2.4V
Fall Time	500	2000	ps	Voh=2.4V, Vol=0.4V
Cycle to Cycle jitter		250	ps	Measured at 1.5V
Duty Cycle	45	55	%	Measured at 1.5V
Pull-Up Current Min	-33		mA	Vout=1.0V
Pull-Up Current Max		-33	mA	Vout=3.135V
Pull-Down Current Min	30		mA	Vout=1.95V
Pull-Down Current Max		38	mA	Vout=0.4V

9.7 48M Electrical Characteristics

<i>VDD48= 3.3V ± 5 %, TA = 0°C to +70°C, Test load, CI=10pF,</i>				
Parameter	Min	Max	Units	Test Conditions
Rise Time	500	2000	ps	Vol=0.4V, Voh=2.4V
Fall Time	500	2000	ps	Voh=2.4V, Vol=0.4V
Long term jitter		500	ps	Measured at 1.5V
Duty Cycle	45	55	%	Measured at 1.5V
Pull-Up Current Min	-33		mA	Vout=1.0V
Pull-Up Current Max		-33	mA	Vout=3.135V
Pull-Down Current Min	30		mA	Vout=1.95V
Pull-Down Current Max		38	mA	Vout=0.4V



STEPLESS FOR INTEL 915/925 CHIPSETS

9.8 REF Electrical Characteristics

<i>VDD= 3.3V ± 5 %, TA = 0°C to +70°C, Test load, CI=10pF,</i>				
Parameter	Min	Max	Units	Test Conditions
Rise Time	500	2000	ps	Vol=0.4V, Voh=2.4V
Fall Time	500	2000	ps	Voh=2.4V, Vol=0.4V
Cycle to Cycle jitter		1000	ps	Measured at 1.5V
Duty Cycle	45	55	%	Measured at 1.5V
Pull-Up Current Min	-29		mA	Vout=1.0V
Pull-Up Current Max		-23	mA	Vout=3.135V
Pull-Down Current Min	29		mA	Vout=1.95V
Pull-Down Current Max		27	mA	Vout=0.4V

9.9 DOT 0.7V Electrical Characteristics

<i>VDD= 3.3V ± 5 %, TA = 0°C to +70°C, Test load Rs=33, Rp=49.9 CI=2pF, Vol=0.175V, Voh=0.525V, Vr=475, IREF=2.32mA, loh=6*IREF</i>				
Parameter	Min	Max	Units	Test Conditions
Rise Time	175	700	ps	Measure Single Ended waveform
Fall Time	175	700	ps	Measure Single Ended waveform
Absolute crossing point Voltages	250	550	mV	Measure Single Ended waveform
Voltage High	660	850	mV	Measure Single Ended waveform
Voltage Low	-150		mV	Measure Single Ended waveform
Cycle to Cycle jitter		250	ps	Measure Differential waveform
Duty Cycle	45	55	%	Measure Differential waveform

W83195BR/G-101



STEPLESS FOR INTEL 915/925 CHIPSETS

10. ORDERING INFORMATION

PART NUMBER	PACKAGE TYPE	PRODUCTION FLOW
W83195BR-101	56 PIN SSOP	Commercial, 0°C to +70°C
W83195BG-101	56 PIN SSOP(Lead free)	Commercial, 0°C to +70°C

11. HOW TO READ THE TOP MARKING

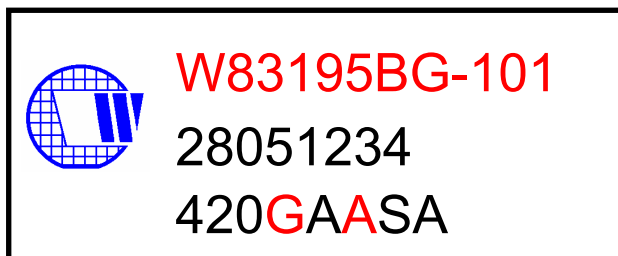
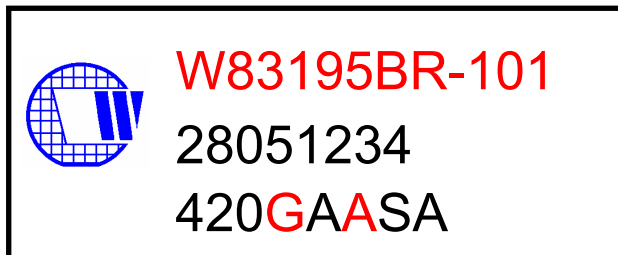

1st line: Winbond logo and the type number:

Normal part: W83195BR-101, Lead free part: W83195BG-101

2nd line: Tracking code 2 8051234

2: wafers manufactured in Winbond FAB 2

8051234: wafer production series lot number

3rd line: Tracking code 420 G A A SA

420: packages made in '2004, week 20

G: assembly house ID; O means OSE, G means GR

A: Internal use code

A: IC revision

SA: mask version

All the trademarks of products and companies mentioned in this data sheet belong to their respective owners.

W83195BR/G-101



STEPLESS FOR INTEL 915/925 CHIPSETS

12. PACKAGE DRAWING AND DIMENSIONS

56 PIN SSOP-300mil

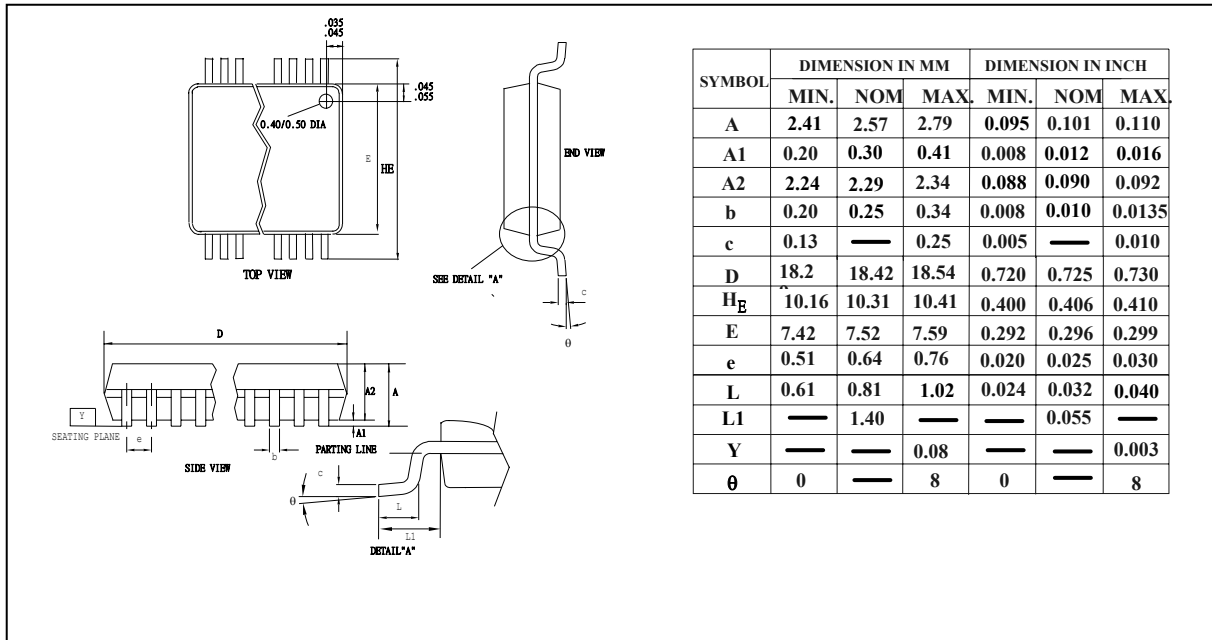

W83195BR/G-101



STEPLESS FOR INTEL 915/925 CHIPSETS

Important Notice

Winbond products are not designed, intended, authorized or warranted for use as components in systems or equipment intended for surgical implantation, atomic energy control instruments, airplane or spaceship instruments, transportation instruments, traffic signal instruments, combustion control instruments, or for other applications intended to support or sustain life. Further more, Winbond products are not intended for applications wherein failure of Winbond products could result or lead to a situation wherein personal injury, death or severe property or environmental damage could occur.

Winbond customers using or selling these products for use in such applications do so at their own risk and agree to fully indemnify Winbond for any damages resulting from such improper use or sales.

Please note that all data and specifications are subject to change without notice.
All the trademarks of products and companies mentioned in this datasheet belong to their respective owners.