

Programmable Timer/Counter

GENERAL DESCRIPTION

The XR-2240 Programmable Timer/Counter is a monolithic controller capable of producing ultra-long time delays without sacrificing accuracy. In most applications, it provides a direct replacement for mechanical or electromechanical timing devices and generates programmable time delays from micro-seconds up to five days. Two timing circuits can be cascaded to generate time delays up to three years.

As shown in Figure 1, the circuit is comprised of an internal time-base oscillator, a programmable 8-bit counter and a control flip-flop. The time delay is set by an external R-C network and can be programmed to any value from 1 RC to 255 RC.

In astable operation, the circuit can generate 256 separate frequencies or pulse-patterns from a single RC setting and can be synchronized with external clock signals. Both the control inputs and the outputs are compatible with TTL and DTL logic levels.

FEATURES

- Timing from micro-seconds to days
- Programmable delays: 1 RC to 255 RC
- Wide supply range; 4V to 15V
- TTL and DTL compatible outputs
- High accuracy: 0.5%
- External Sync and Modulation Capability
- Excellent Supply Rejection: 0.2 %N

APPLICATIONS

- Precision Timing
- Long Delay Generation
- Sequential Timing
- Binary Pattern Generation
- Frequency Synthesis
- Pulse Counting/Summing
- A/D Conversion
- Digital Sample and Hold

ABSOLUTE MAXIMUM RATINGS

Supply Voltage	18V
Power Dissipation Ceramic Package	750 mW
Derate above + 25°C	6 mw/°C
Operating Temperature XR-2240	-55°C to + 125°C
Storage Temperature	-65°C to + 150°C

FUNCTIONAL BLOCK DIAGRAM

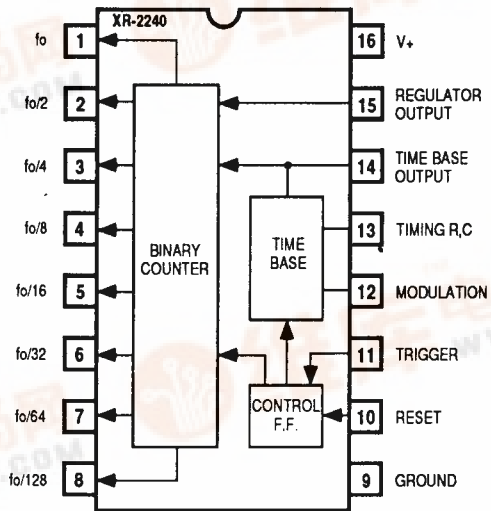

SYSTEM DESCRIPTION

The XR-2240 is a combination timer/counter capable of generating accurate timing intervals ranging from microseconds through several days. The time base works as an astable multivibrator with a period equal to RC. The eight bit counter can divide the time base output by any integer value from 1 to 255. The wide supply voltage range of 4.5 to 15 V, TTL and DTL logic compatibility, and 0.5% accuracy allow wide applicability. The counter may operate independently of the time base. Counter outputs are open collector and may be wire- OR connected.

The circuit is triggered or reset with positive going pulses. By connecting the reset pin (Pin 10) to one of the counter outputs, the time base will halt at timeout. If none of the outputs are connected to the reset, the circuit will continue to operate in the astable mode. Activating the trigger terminal (Pin 11) while the timebase is stopped will set all counter outputs to the

XR-2240

ELECTRICAL PERFORMANCE CHARACTERISTICS - XR-2240

TEST	CONDITIONS	TEMPERATURE	LIMITS		UNIT	GROUP A SUBGROUP
			MIN	MAX		
Supply Current	V+ = 5V	TA = +25°C -55°C ≤ TAS ≤ +125°C		6	mA	1
				8	mA	2, 3
Supply Current	V+ = 15V	TA = +25°C -55°C ≤ TAS ≤ +125°C		16	mA	1
				20	mA	
Regulator Output	V+ = 5V	TA = +25°C -55°C ≤ TAS ≤ +125°C	4.1		V	1
			3.7		V	2, 3
Regulator Output	V+ = 15V	TA = +25°C -55°C ≤ TAS ≤ +125°C	6.0	6.6	V	1
			5.2	7.0	V	2, 3
Timing Accuracy	R = 10KΩ, C = 0.1μF	TA = +25°C -55°C ≤ TAS ≤ +125°C		2.0	%	9
				6.0	%	10, 11
Supply Drift	8V ≤ V+ ≤ 15V	TA = +25°C -55°C ≤ TAS ≤ +125°C		0.2	%/V	9
				0.4	%/V	10, 11
Maximum Frequency	R = 1 KΩ, C = 0.007μF	TA = +25°C -55°C ≤ TAS ≤ +125°C	100		KHz	9
			85		KHz	10, 11
Modulation Voltage Level	V+ = 5V	TA = +25°C -55°C ≤ TAS ≤ +125°C	3	4	V	1
			3	4	V	2, 3
Trigger Threshold		TA = +25°C -55°C ≤ TAS ≤ +125°C		2.0	V	1
				2.3	V	2, 3
Reset Threshold		TA = +25°C -55°C ≤ TAS ≤ +125°C		2.0	V	1
				2.3	V	2, 3
Max Toggle Rate		TA = +25°C	0.5		MHz	9
Input Threshold	V+ = 5V	TA = +25°C -55°C ≤ TAS ≤ +125°C	1.0		V	1
			0.5		V	2, 3
Output Sink Threshold	VOL ≤ 0.4V VREG = V+ = 5V	TA = +25°C -55°C ≤ TAS ≤ +125°C	3		mA	1
			2		mA	2, 3
Output Leakage Current	VOH = 15V	TA = +25°C -55°C ≤ TAS ≤ +125°C		8	μA	1
				8	μA	2, 3

Quad Line Driver/Receiver

GENERAL DESCRIPTION

The XR-1488 is a monolithic quad line driver designed to interface data terminal equipment with data communications equipment in conformance with the specifications of EIA Standard No. RS232C. This extremely versatile integrated circuit can be used to perform a wide range of applications. Features such as output current limiting, independent positive and negative power supply driving elements, and compatibility with all DTL and TTL logic families greatly enhance the versatility of the circuit.

The XR-1489A is a monolithic quad line receiver designed to interface data terminal equipment with data communications equipment. The XR-1489A quad receiver along with its companion circuit, the XR-1488 quad driver, provide a complete interface system between DTL or TTL logic levels and the RS232C defined voltage and impedance levels.

ABSOLUTE MAXIMUM RATINGS

Power Supply		
XR-1488	± 15 Vdc	
XR-1489A	+ 10 Vdc	
Power Dissipation		
Ceramic Package	1000 mW	
Derate above +25°C	6.7 mW/°C	
Plastic Package	650 mW/°C	
Derate above +25°C	5 mW/°C	

ORDERING INFORMATION

Part Number	Package	Operating Temperature
XR-1488N	Ceramic	0°C to +70°C
XR-1488P	Plastic	0°C to +70°C
XR-1489AN	Ceramic	0°C to +70°C
XR-1489AP	Plastic	0°C to +70°C

FUNCTIONAL BLOCK DIAGRAMS

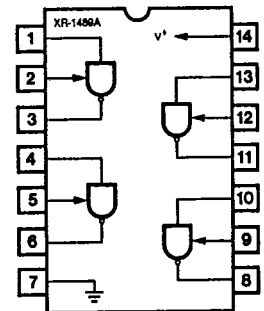
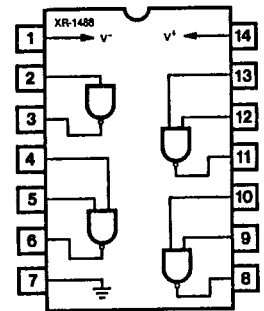

SYSTEM DESCRIPTION

The XR-1488 and XR-1489A are a matched set of quad line drivers and line receivers designed for interfacing between TTL/DTL and RS232C data communication lines.

The XR-1488 contains four independent split supply drivers, each with a ± 10 mA current limited output. In RS232C applications, the slew rate can be reduced to the 30 V/ μ S limit by shunting the output to ground with a 410 pF capacitor. The XR-1489A contains four independent line receivers, designed for interfacing RS232C TTL/DTL. Each receiver features independently programmable switching thresholds with hysteresis, input protection to ± 30 V. The output can typically source 3 mA and sink 20 mA.