

Description

The YB1314 charge pump drive up to 4 white LEDs with regulated constant current. The devices can be used to produce current levels up to 30mA for each output from a 2.7V to 5.5V input. The 1MHz fix-frequency switching allows for tiny external components, and the regulation scheme is optimized to ensure low EMI and low input ripple.

Serial data input control is used to enable, disable and set the LED drive current for a 32 level logarithmic scale LED brightness control. Internal softstart circuitry effectively reduces the in-rush current. YB1314 also provides short circuit protection, over-temperature protection and over-voltage protection. In shutdown mode, the shutdown current is less than 1 μ A. YB1314 is available in a QFN-16 3*3 package.

Features

- Input Range : 2.7V to 5.5V
- Drives up to 4 LEDs at 30mA Each
- 1MHz Internal Oscillator
- Thermal Protection Shutdown
- Output Short-circuit Current Limit and Overvoltage Protection
- Undervoltage Lockout With Hysteresis
- Automatic Soft-Start Reduces In-Rush Current
- Three Charge Pump Mode : 1x/1.5x/2x
- 3mm x 3mm QFN package

Applications

- White LED Backlighting
- Handheld PCs and PDAs
- Mobile Phone

Typical Application Circuit

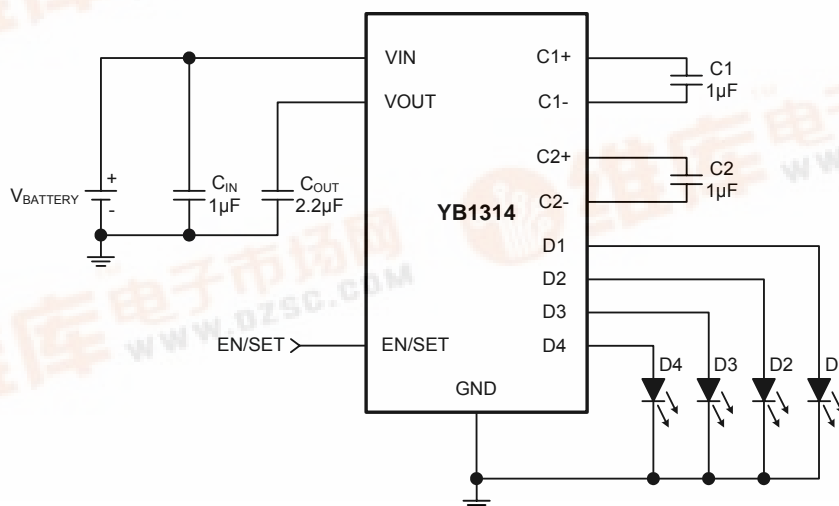

Figure 1. Typical application circuit