



YDA131

D-1

STEREO 2.5W DIGITAL AUDIO POWER AMPLIFIER

■ Outline

The YDA131 is the high efficient digital audio power amplifier IC that operates on a single 5V power supply. This IC is capable of providing output power of 2.5W/channel, which is at the highest level as a device on a single 5V power supply. By adopting Yamaha's proprietary modulation system, the device provides low distortion and high signal to noise ratio at the highest level among digital amplifiers in the equivalent class. This IC accepts analog signal, converts it into digital pulse by the digital modulation circuitry and outputs the signal from the large current capacity buffers. The digital pulse signal that is outputted from the output buffer is converted into audio signal through an external low pass filter, and sent to the speakers. This IC has the overcurrent detection function that detects short-circuiting of speaker terminal end and the high temperature detection function that detects abnormal high temperature. With the overcurrent detection function, this IC generates a warning signal when the current that flows in the output buffers of left and right channels exceeds a fixed value. With the high temperature detection function, this IC generates a warning signal when the junction temperature becomes abnormal. Furthermore, this IC builds in function that mute an audio output and shut off all functions of the IC. By this function, power consumption is restrained at the minimum.

■ Features

- High output power
2.5 W @ VDD=5.0V, 4Ω (THD+N<10%)
- High efficiency operation
85 % @ VDD=5.0V, RL=8Ω
75 % @ VDD=5.0V, RL=4Ω
- Low distortion(THD+N)
0.018 % @ Po=1.0W, 1kHz, RL=4Ω
- High signal to noise ratio
103dB @ VDD=5.0V, Input sensitivity =1.0V, RL=4Ω
97dB @ VDD=5.0V, Input sensitivity=150mV, RL=4Ω
- Low consumption current
14.0 mA @ VDD=5.0V, no signal(no filter)
7.0 mA @ VDD=5.0V, at mute
1 μA @ VDD=5.0V, at sleep
- Channel separation
80dB @ 1kHz
- Any gain setting by external resistor
- Any setting of starting time by VREF capacitor
- Sleep function by SLEEP terminal
- Output mute function by MUTE terminal
- Over current detection function of speaker terminal end (Ground short-circuiting, Load short-circuiting)
- High temperature detection function
- Pop noise suppression function at turn-on and turn-off
- Analog input/BTL(Bridge-Tied Load)output
- 24-pin plastic SSOP
Pin lead plating with Pd free (YDA131-EZ)

YAMAHA CORPORATION

YDA131 CATALOG
CATALOG No.:LSI-4DA131A40
2004.12

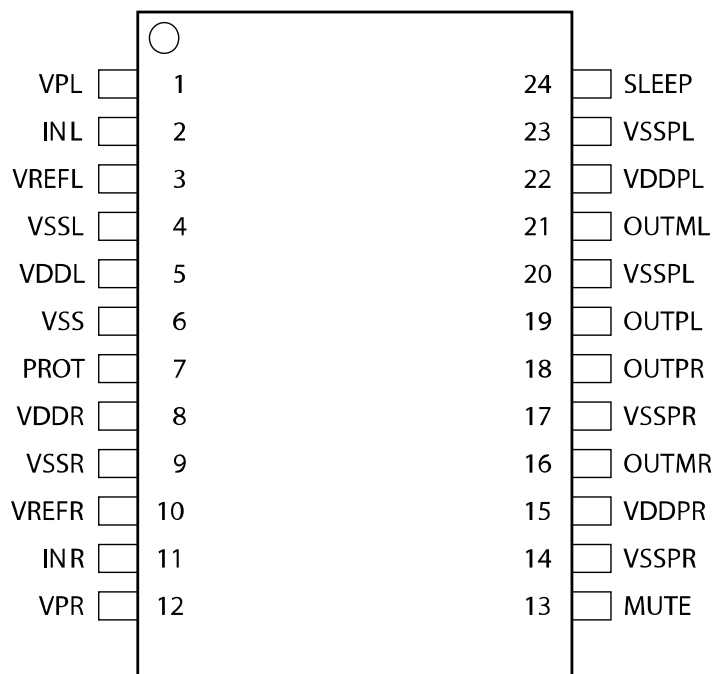

■ Terminal configuration

<24 pin SSOP Top View>

■ Terminal function

No.	Name	I/O	Function
1	VPL	AO	Lch gain control
2	INL	AI	Lch audio input
3	VREFL	AO	Lch voltage reference
4	VSSL	-	VSS for analog circuit of Lch
5	VDDL	-	VDD for analog circuit of Lch
6	VSS	-	VSS for control circuit and protection circuit
7	PROT	O	Warning output for protection function
8	VDDR	-	VDD for analog circuit of Rch
9	VSSR	-	VSS for analog circuit of Rch
10	VREFR	AO	Rch voltage reference
11	INR	AI	Rch audio input
12	VPR	AO	Rch gain control
13	MUTE	I	Output shut off control
14	VSSPR	-	VSS for output buffer of Rch
15	VDDPR	-	VDD for output buffer of Rch
16	OUTMR	O	Negative output of Rch
17	VSSPR	-	VSS for output buffer of Rch
18	OUTPR	O	Positive output of Rch
19	OUTPL	O	Positive output of Lch
20	VSSPL	-	VSS for output buffer of Lch
21	OUTML	O	Negative output of Lch
22	VDDPL	-	VDD for output buffer of Lch
23	VSSPL	-	VSS for output buffer of Lch
24	SLEEP	I	Operation shut off control

Note. A: Analog terminal

YDA131



Internal block diagram

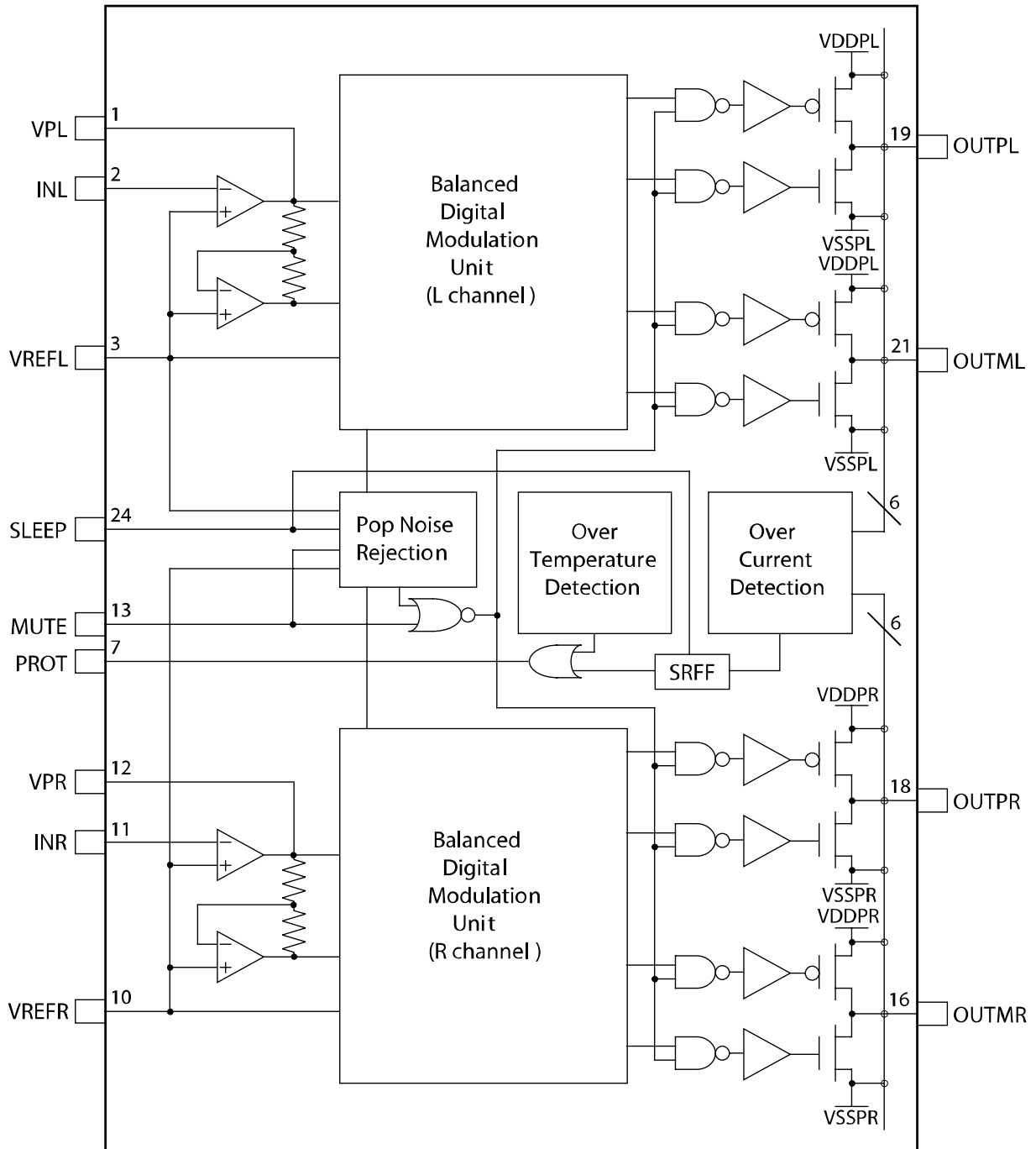

■ Description of terminal functions

VDDPL, VSSPL, VDDPR, VSSPR (Pin No.22, 20&23, 15, 14&17)

These are the power supply and ground terminals for the output buffers.

VDDPL and VSSPL are the power supply and ground terminals for the left channel, and VDDPR and VSSPR are the power supply and ground terminals for the right channel.

There are two VSSPL terminals and two VSSPR terminals, both of which are to be connected with similar impedance (length of patterns on the printed circuit board).

OUTPL, OUTML, OUTPR, OUTMR (Pin No.19, 21, 18, 16) [Digital-OUT]

These are the output buffer terminals and output digital pulse signal that has been modulated by PWM system.

OUTPL and OUTML are the output buffer terminals for the left channel, OUTPL is the positive terminal and OUTML is the negative terminal.

OUTPR and OUTMR are the output buffer terminals for the right channel, OUTPR is the positive terminal and OUTMR is the negative terminal.

Since both channels are BTL (Bridge-Tied Load) output, the minus terminal is not at the ground potential.

Connect the IC with the speakers through an LC filter as shown in the "Application circuit" for the purpose of removing the carrier frequency signal.

VDDL, VSSL, VDDR, VSSR (Pin No.5, 4, 8, 9)

These are the power supply and ground terminals for the circuitries other than the output buffers.

VDDL and VSSL are the power supply and ground terminals for the left channel circuit.

VDDR and VSSR are the power supply and ground terminals for the right channel circuit.

VSS (Pin No.6)

This is the ground terminal for the protection circuitry and the control circuitry.

Connect VSS to the left-channel analog ground near the terminal.

INL, VPL, INR, VPR (Pin No.2, 1, 11, 12) [Analog]

These are the audio signal input and gain adjustment terminals.

INL and VPL are the audio signal input and gain adjustment terminals for the left channel.

INR and VPR are the audio signal input and gain adjustment terminals for the right channel.

The terminals are connected respectively to the inversion input and output of the first stage inversion operational amplifiers.

The amplifier gain is set by connecting an input resistor and a feedback resistor to both terminals as shown the "Application circuit". The use of this inversion operational amplifier allows making a simple filter.

For the details, refer to "Gain setting" on page 6.

VREFL, VREFR (Pin No.3, 10) [Analog]

These are reference voltage output terminals.

VREFL is the reference voltage output terminal for the left channel, and VREFR is the reference voltage output terminal for the right channel. Connect the same capacitors to these terminals. The starting time is set by changing the capacitance connected to VREFL and VREFR terminals.

For the details, refer to "Pop noise reduction function" on page 9.

SLEEP (Pin No.24) [Digital-IN]

This is the operation shut off control terminal.

The terminal controls both channels at the same time. When SLEEP terminal is set at "H" level, all of the internal circuits are placed in the shut off state, output is placed in the muted state, and the IC is placed in the sleep state.

At this time the power consumption is minimized, and warning signal (PROT terminal output) is set at "L" level.

When SLEEP terminal is set at "L" level, this IC goes into normal operation after sufficient time (starting time) to make each reference voltage reaches a fixed potential.

MUTE (Pin No.13) [Digital-IN]

This is the output shut-off control terminal.

The terminal controls both channels at the same time. When MUTE terminal is set at "H" level, all of the output buffer terminals, OUTPL, OUTML, OUTPR and OUTMR output "L" level, and this IC changes in mute state.

When MUTE terminal is set at "L" level, all of the output buffer terminals, OUTPL, OUTML, OUTPR and OUTMR output the digital pulse signal.

PROT (Pin No.7) [Digital-OUT]

This is the warning signal output terminal for both overcurrent detection and high temperature detection. PROT terminal outputs "H" level when either of those detection circuitries detects a hazardous state.

For the method of controlling MUTE terminal and SLEEP terminal by using PROT terminal, refer to "Overcurrent detection function and high temperature detection function" on page 7.

■ **Description of operation functions**

Refer to "Connection circuit example" on page 11, when reading the following descriptions.

● **Gain setting**

This IC consists of the first stage inversion operational amplifier, and the fixed-gain digital power amplifier. The gain of the digital power amplifier is fixed at 8 dB.

The gain of the first stage inversion operational amplifier is set with the resistance values of the input resistor (R1) and feedback resistor (RF) as described by "Formula 1". To reduce pop noise, it is necessary to observe the restrictions described in "Pop noise reduction function" on page 9. Use the feedback resistor (RF) of 10kΩ or higher, because the driving capability of the operational amplifier is limited.

In "Application circuit", input resistor (R1)=7.5kΩ and feedback resistor (RF)=47kΩ and the gain of the first stage inversion operational amplifier is set at 16 dB, as described in "Figure 1: First stage inversion operational amplifier input circuit example". Therefore, the total gain at this case is given as described below.

8dB (fixed gain of the digital power amplifier) + 16dB (gain of the first stage inversion operational amplifier) = 24dB

In the "Application circuit", low pass filter capacitor (CF) is added to limit the band width of the input signal, as described in "Figure 1: First stage inversion operational amplifier input circuit example", whereby the value can be adjusted as necessary. To limit the input DC current, DC cutting capacitor (CI) is added, whereby this capacitor and input resistor (R1) constitute a high pass filter.

The cut off frequency fc of this high pass filter is set as necessary, and can be decided by "Formula 2".

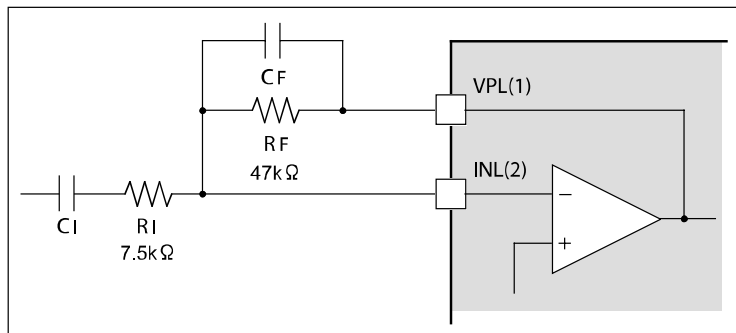

Figure 1: First stage inversion operational amplifier input circuit example

Formula 1: Gain of first stage inversion operational amplifier $A_v(\text{dB}) = 20 \cdot \log(R_F/R_1)$

Formula 2: Cut off frequency $f_c(\text{Hz}) = 1/(2 \cdot \pi \cdot R_1 \cdot C_I)$

When low band boost function is needed due to a reason such as small diameter speaker, the low boost function can be realized by making the circuit of the first stage operational amplifier as shown in "Figure 2: Low band boost circuit example". For this circuit, the gain is increased by +3dB at the frequency fb of "Formula 3", and the low band boost quantity Ab is decided by "Formula 4". At this time, the frequency characteristic is as shown in "Figure 3: Frequency characteristic at low band boost".

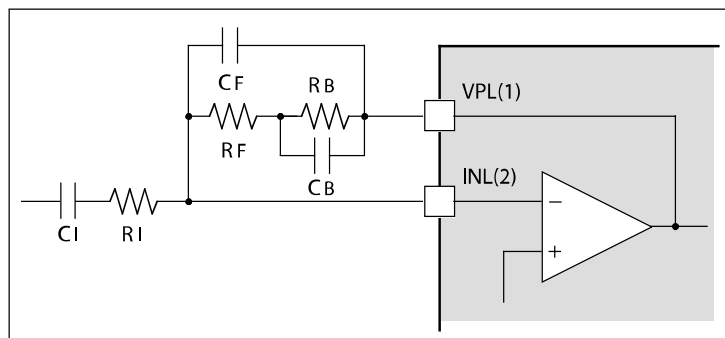

Figure 2: Low band boost circuit example

Formula 3: Frequency at which the gain increased by +3dB $f_b(\text{Hz}) = 1/(2 \cdot \pi \cdot R_F \cdot C_B)$

Formula 4: Boost quantity $A_b(\text{dB}) = 20 \cdot \log((R_F + R_B)/R_F)$

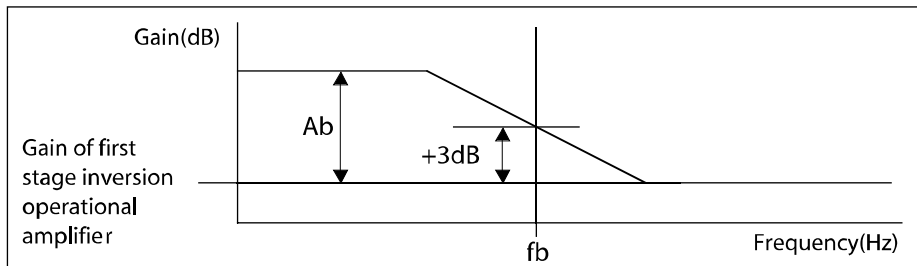

Figure 3: Frequency characteristic at low band boost

● Mute function

When MUTE terminal is set at "H" level, all of the output buffer terminals, OUTPL, OUTML, OUTPR and OUTMR, output "L" level, and this IC changes into mute state. When MUTE terminal is set at "L" level, all of the output buffer terminals, OUTPL, OUTML, OUTPR and OUTMR, output digital pulse signal.

This IC includes a pop noise reduction function circuitry in both cases the mute control is enabled and disabled.

In the mute mode, the overcurrent detecting function is disabled. However, all the output buffers outputting "L" level, the electric current is at a safe level even if the buffer terminals are short-circuited.

● Sleep function

When SLEEP terminal is set at "H" level, all of the internal circuitries are placed in the shut-off state, output is placed in the mute state, and this IC is placed in the sleep state. In this state, the power consumption is minimized, overcurrent detection function and high temperature detection function are disabled, and warning signal (PROT terminal output) is set at "L" level.

When SLEEP terminal is set at "L" level, this IC goes into normal operation state after sufficient time (starting time) to make each reference voltage reaches an established potential.

This IC includes a pop noise reduction function in both cases the sleep control is enabled and disabled.

● Overcurrent detection function and high temperature detection function

This IC includes the output buffer overcurrent detection function and high temperature detection function. When either detection circuit detects an abnormality, warning signal (PROT terminal) output is set at "H" level.

• Overcurrent detection function

When either of four speakers terminal end (between LC filter and speaker) short-circuits with VSS terminal or reverse polarity speaker terminal end, this IC determines that the overcurrent state has occurred and outputs warning signal (PROT terminal ="H" level).

When a warning is signaled, MUTE terminal or SLEEP terminal should be controlled externally to place this IC in the muted state or sleep state immediately to protect this IC.

And it does not cope with over current protection that short-circuiting of output terminals (OUTPL, OUTML, OUTPR, OUTMR) and VSS terminal, and short-circuiting between each output terminal.

When the warning signal (PROT terminal ="H" level) is outputted due to overcurrent detection, this IC keeps the warning signal output after the current return to normal state.

The warning signal is cancelled by changing the state of SLEEP terminal as "L" level, "H" level and "L" level in this order or by turning on the power supply again.

When this IC is used with application that speaker terminal is likely to short-circuit during operation, use the following over current detection and protection circuit.

(1) Connecting PROT terminal output to MUTE terminal.

When an overcurrent is detected, the output goes into mute state. In this case, warning signal output and mute state cannot be cancelled unless otherwise the power supply is turned on again or the state of SLEEP terminal is changed as "L" level, "H" level and "L" level in this order.

(2) Attaching a fall delay circuit to PROT terminal, and connecting it to SLEEP terminal.

For the connection, refer to "Figure 4: PROT terminal output connection circuit example" in the following "Restrictions" section.

When overcurrent is detected, this IC goes into sleep state, and the output goes into mute state, and warning signal output is cancelled. The sleep state is cancelled after the elapse of the fall delay time, and return to normal operation.

If the overcurrent state remains even after the restart, the sleep and start are repeated.

(3) If the current capacity of used power supply exceeds 1.5A, connect shottkey-diode between output terminals (OUTPL, OUTML, OUTPR, OUTMR) and VSS, and connect between PROT and MUTE terminal or SLEEP terminal as (1), (2).

•High temperature detection function

When this IC operates with its internal temperature exceeding the maximum rating (junction temperature), it determines itself as a high temperature state, and outputs the warning signal (PROT terminal ="H" level).

When a warning is signaled, MUTE terminal or SLEEP terminal should be controlled externally to place this IC in muted state or sleep state immediately to protect this IC. If the internal overheating is due to the overload output, the temperature rise is avoided by aforesaid control.

When the warning signal is generated due to the high temperature detection, and then, the temperature is reduced sufficiently by the protection action with the control of MUTE terminal or SLEEP terminal, this IC cancels the warning signal. The warning signal is also cancelled by setting the state of SLEEP terminal at "L" level or by turning on the power supply again.

The control through the use of PROT terminal, MUTE terminal or SLEEP terminal is made also for the case of high temperature detection like the case of the overcurrent detection.

In case of high temperature detection, this IC cancels the warning signal if the temperature is reduced sufficiently.

Thus, this IC can return to the normal operation even if PROT terminal and MUTE terminal are connected.

•Restrictions

A pulse as short as about 1 μ s may be outputted from PROT terminal when the power supply is turned on or the state of SLEEP terminal is changed from "H" level to "L" level.

When this IC is controlled using SLEEP terminal and PROT terminal, connect an LPF (low pass filter) that can cut pulse about 10 μ s to PROT terminal.

"Figure 4: PROT terminal output connection circuit example" is the connection circuit example for the case LPF (low pass filter) and fall delay circuit are attached to PROT terminal and connected to SLEEP terminal.

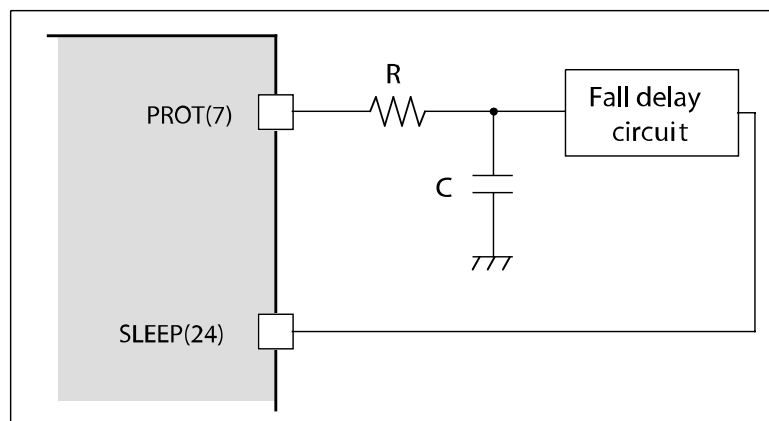

Figure 4: PROT terminal output connection circuit example

● Pop noise reduction function

This IC includes pop noise reduction function that works when turning on and shutting off the power supply, and controlling the mute or sleep functions.

• When turn on the power supply

This IC is in mute state immediately after turning on the power supply.

The starting process is performed at the power on (sleep cancellation), and after the internal operation stabilizes, the mute state is cancelled. This operation minimizes the generation of pop noise at turning on the power supply.

To make this function operate effectively, it is necessary to use the input resistor "R1" of the first stage inversion operational amplifier, the input AC coupling capacitor "C1" of the first stage inversion operational amplifier, and reference voltage stabilizing capacitor "CR1" under the following condition.

These values must be same for both channels.

$$\text{Condition: } CR1 > (R1 * C1)/5000$$

To make the pop noise reduction function operate effectively when turning on the power supply, the capacitors (CR1) of VREFL and VREFR terminals must be discharged sufficiently before turning on the power supply again. If you turn on the power supply again without discharged sufficiently these capacitors, this function does not operate effectively, and there is a possibility that pop noise generates.

• Starting time

Starting time is a period for each reference voltage to reach the specified potential (for charging capacitors (CR1) of VREFL and VREFR terminals) when the power supply is turned on or is turned on again. This period varies in relation to the capacitance (CR1) of VREFL and VREFR terminals.

The table of starting time is as follows:

Table: Starting time

CR1capacitor(μF)	Starting time (sec)
2	0.13
10	0.33
30	0.85
50	1.40

• When shutting off the power supply

This IC performs muting processing internally when the power supply voltage has changed by more than 10% in a very short period or when the power supply voltage is reduced below 3.0V to reduce the pop noise when the IC is shut off.

To make this function operate efficiently, it is necessary to fall the power voltage quickly when shutting off the power supply.

When the power is supplied to the IC through a voltage regulator and a large capacitance is connected after the regulator, such as the case shown in "Figure 5: Power supply fall acceleration circuit example", the voltage of VDD can be reduced quicker if a diode is connected to it.

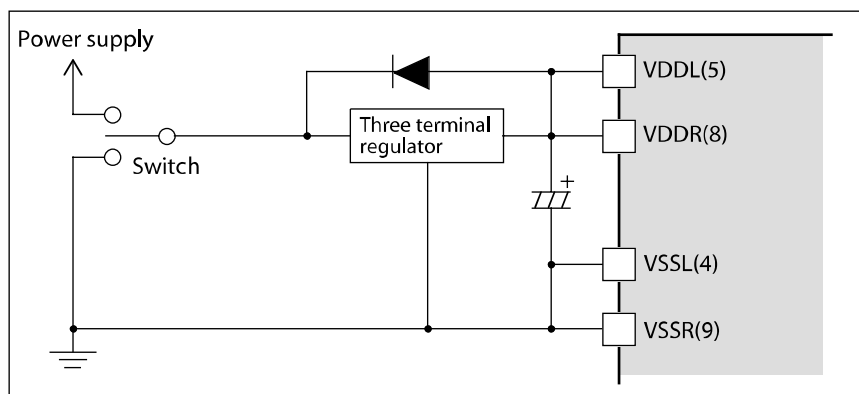

Figure 5: Power supply fall acceleration circuit example

If power supply voltage changes exceeding 10% in a very short period, this IC may go into mute state internally due to the pop noise reduction function described before. Therefore, it is recommended to use this IC in normal operation so that the change of power supply voltage in a very short period wouldn't exceed 10%.

This IC may also go into mute state internally when the power supply voltage is reduced temporarily below 3.0V.

Therefore, it is recommended to use this IC in normal operation so that the power supply voltage wouldn't fall below 3.0V.

● Power consumption

This IC is capable of outputting up to 5W in total, or 2.5W per one channel. Digital amplifiers can be used without heat sink because their operation efficiency is higher than conventional linear amplifiers.

When using this IC, ensure that the power consumption does not exceed the maximum allowable loss that is defined as the absolute maximum rating.

The power consumption of this device can be obtained by using "Formula 5".

In the following formula, P_D represents the power consumption, P_o represents average output power, R_L represents the output load impedance, and P_{ic} represents the internal control circuit loss.

$$\text{Formula 5: } P_D(W) = P_o(W) * 1.05 / R_L(\Omega) + P_{ic}(W)$$

$$P_{ic} = 0.09W \text{ (VDD=5.0V)}$$

$$P_{ic} = 0.04W \text{ (VDD=3.3V)}$$

The maximum allowable loss P_{Dmax} is obtained by using "Formula 6" based on the absolute maximum rating of the junction temperature of this IC.

In the following formula, T_{jmax} represents the absolute maximum rating of the junction temperature, θ_{ja} represents thermal resistance of SSOP24 package, and T_a represents the ambient temperature.

$$\text{Formula 6: } P_{Dmax}(W) = (T_{jmax}(^{\circ}C) - T_a(^{\circ}C)) / \theta_{ja}$$

$$\theta_{ja} = 96.7^{\circ}C/W$$

$$T_{jmax} = 125^{\circ}C$$

For example, when VDD=5.0V, output load=4Ω, and 2.5W * 2ch is outputted continuously, the maximum allowable loss is exceeded. However, this IC can deal with reproduction of normal music signal sources sufficiently because it is believed to be sufficient that average output power of the normal music signal sources is estimated at 1/8 of the maximum output.

● Load impedance and filter constant

The speaker that is connected to this IC is to have the load impedance (R_L) of 4Ω or higher.

Typical filter constants for load impedance (R_L) when the cut-off frequency is set at 50kHz are as shown in the following table.

Table: Filter constant example

Load impedance R_L	L	C
4Ω	10 μH	1 μF
8Ω	22 μH	0.47 μF
16Ω	39 μH	0.27 μF

YDA131



Application circuit

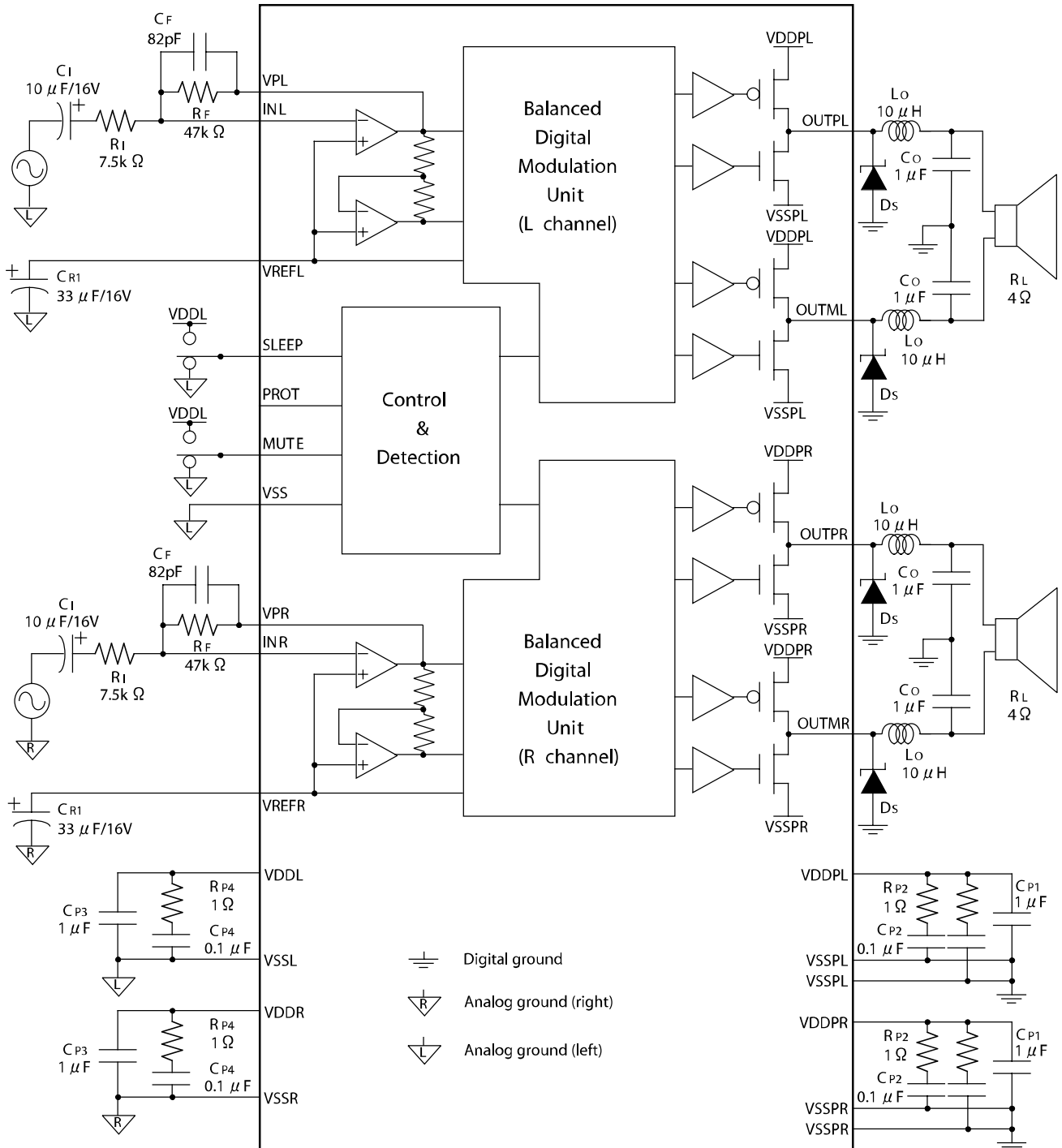

Outline of components that are connected externally to this IC.

CP1, CP3	Capacitors for stabilization of the power supply
CP2, CP4, RP2, RP4	Capacitors and resistors for stabilization of the power supply (snubber)
CR1	Capacitor for stabilization of reference voltage, and capacitor for stabilization of starting.
Ci	Input AC coupling capacitor: Ri and Ci form a high pass filter.
Ri	Inversion input resistor that determines the gain.
Rf	Feedback resistor for determining the gain.
Cf	Capacitor for input low pass filter.
Lo	Output inductance: Being combined with Co, the component forms the secondary filter that removes the high frequency and delivers an amplified audio signal to the load.
Co	Output capacitor
Ds	Shottky-diode for terminal protection (equivalent to 11EQS04)

■ Application notes

Warning for the device which makes sound using speaker.

A speaker radiates heat in a voice-coil by air flow accompanying vibration of a diaphragm. When DC signal (several Hz or less) is input, heat radiation characteristics falls rapidly.

In addition, even if it is used lower than rated input, it may lead to voice-coil burnout, smoke or ignition of a speaker.

In order to avoid such situations, be sure to implement one or more preventive measures from the following.

- 1) Do not select settings (sound creation, sound generation stop with DC offset) which may generate DC signal.
(Since thoroughness of this preventive measure is generally difficult, we recommend the combined use with the following 2, 3 and 4)
- 2) Add the equivalent of DC cut digital filter for cutting DC signal in the digital section.
(As long as "Built-in" is not mentioned in the manual, there is no such built-in circuit inside of a device).
- 3) Add a DC cut capacitor for cutting DC signal in the analog section.
(When addition is specified in the example of a recommended circuit diagram, be sure to add)
- 4) When a latter stage device exists in the signal path from this device to speaker, be sure to realize the DC cut in a latter stage device.

In addition, the above-mentioned measures are based on the assumption that the device itself, DC cut capacitor, and the latter stage device will be in a normal operation. Therefore, it is also necessary to implement measures based on the assumption of these part failures.

■Electrical characteristics

1. Absolute maximum rating

Item	Symbol	Rating	Unit
VDD terminal power supply voltage *1	VDD	$V_{SS} - 0.5 \sim V_{SS} + 6.0$	V
Digital input terminal voltage	VDIN	$V_{SS} - 0.5 \sim V_{DD} + 0.5$	V
Analog input terminal voltage	VAIN	$V_{SS} - 0.5 \sim V_{DD} + 0.5$	V
Storage temperature	TSTG	-50~125	°C
Maximum allowable loss (Ta=85°C)	PD85	413	mW
Maximum allowable loss (Ta=25°C)	PD25	1034	mW
Junction temperature	Tjmax	125	°C

Note. *1:VDD covers all of VDD terminals, including VDDPL, VDDPR, VDDL and VDDR.
Vss covers all of VSS terminals, including VSSPL, VSSPR, VSSL, VSSR and VSS.

2. Recommended operating conditions

Item	Symbol	Min.	Typ.	Max.	Unit
Power supply voltage	VDD	3.15	5.0	5.25	V
Operating ambient temperature (ambient temperature Ta)	TOP	-40	25	85	°C
Output load impedance	RL	4			Ω

3. DC characteristics (VDD=5V±0.25V, Ta=-40 to 85°C)

Item	Symbol	Condition	Min.	Typ.	Max.	Unit
Output voltage "H" level	VOH	IOH= -80μA, PROT terminal	VDD-1.0			V
Output voltage "L" level	VOL	IOL= 1.6mA, PROT terminal			VSS+0.4	V
Input voltage "H" level	VIH	SLEEP, MUTE terminal	3.5			V
Input voltage "L" level	VIL	SLEEP, MUTE terminal			1.0	V
Consumption current 1	IDD1	at SLEEP mode		1		μA
Consumption current 2	IDD2	at MUTE mode		7		mA
Consumption current 3	IDD3	no signal, no filter		14		mA

Note. These values do not guarantee the characteristics at VDD=3.3V±0.15V.

4. Analog characteristics (VDD=5.0V, Ta=25°C, Frequency=1kHz)

Item	Symbol	Condition	Min.	Typ.	Max.	Unit
Maximum output	Po	THD+N=10%, RL=4Ω		2.5		W
Voltage gain (RI=7.5kΩ, RF=47kΩ)	Av	RL=4Ω		24		dB
Total harmonic distortion (20kHz Band Width)	THD+N	RL=4Ω, Po=1.0W		0.018		%
Signal/noise ratio (A-Filter)	SNR	Input sensitivity 1.0V RL=4Ω Input sensitivity 150mV RL=4Ω		103 97		dB dB
Channel separation	CS	RL=4Ω		80		dB
Maximum efficiency	η	RL=8Ω RL=4Ω		85 75		% %
Output offset voltage	Vo	RL=4Ω		6		mV

Note. All the analog characteristics shown above are the values obtained on the DMB-D1, Yamaha's YDA131 evaluation board.

The characteristics may vary according to the coils and capacitors that are used, pattern layout and other factors.

These values do not guarantee the characteristics at VDD=3.3±0.5V.

Characteristics example

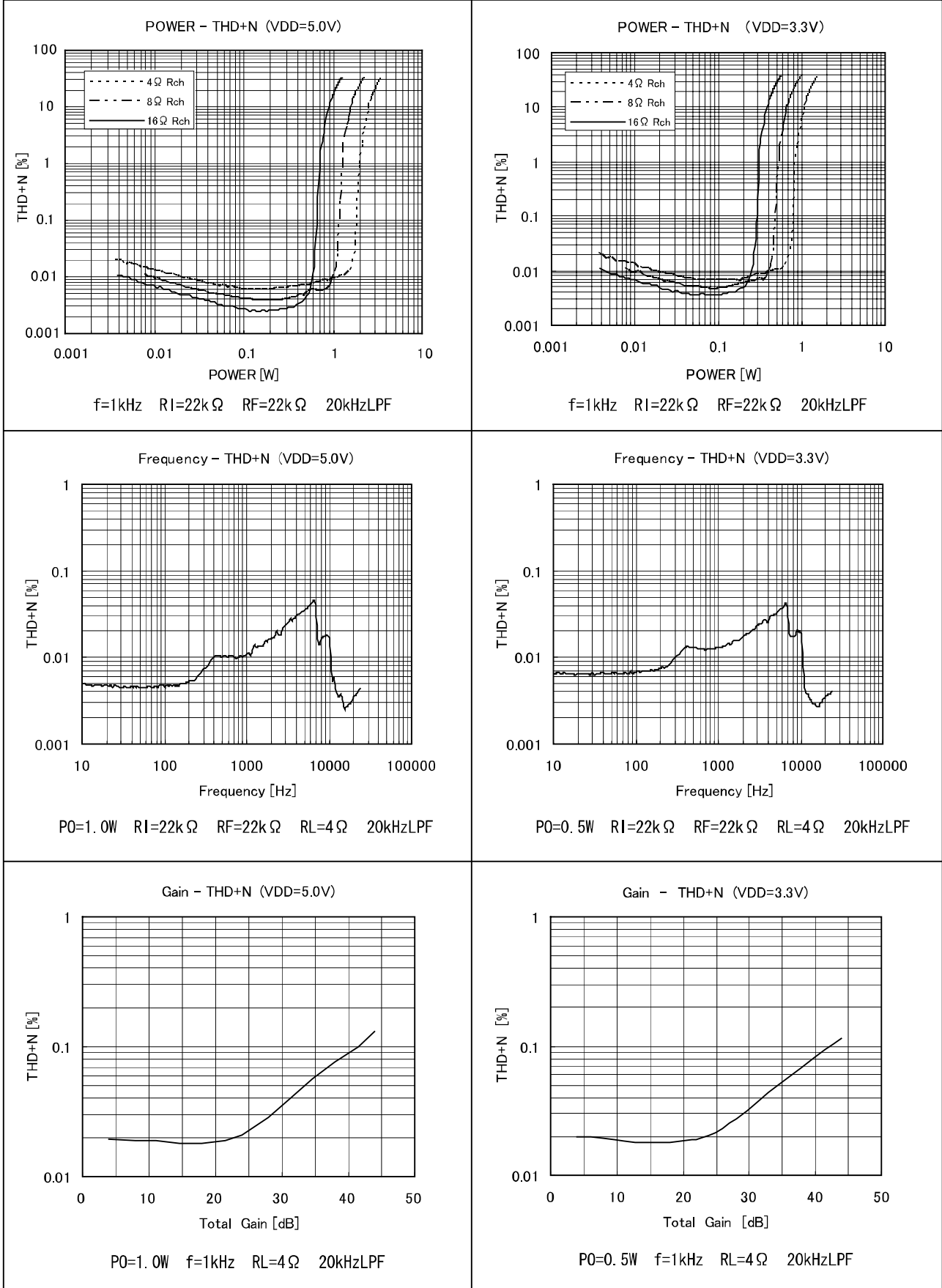

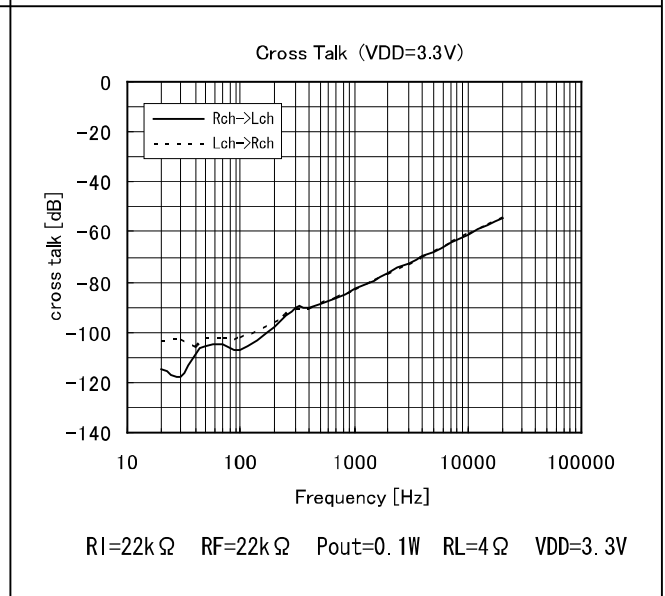
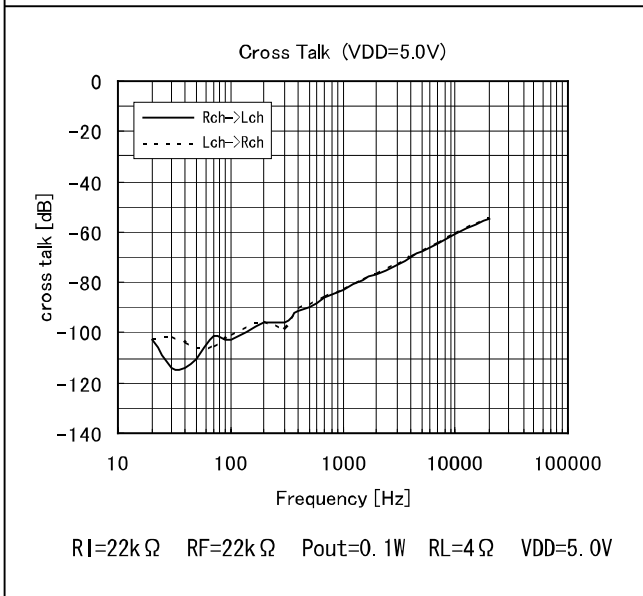
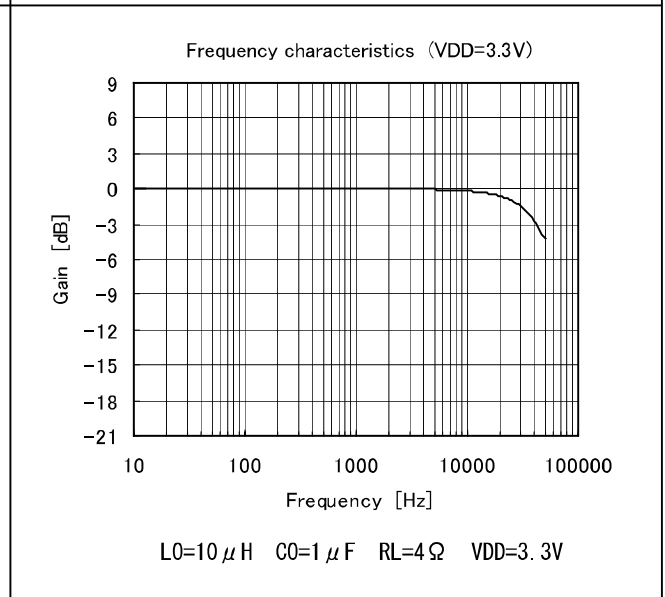
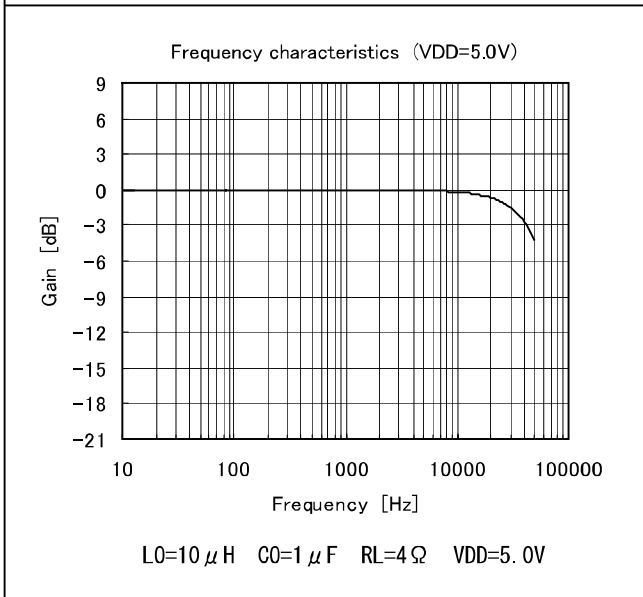
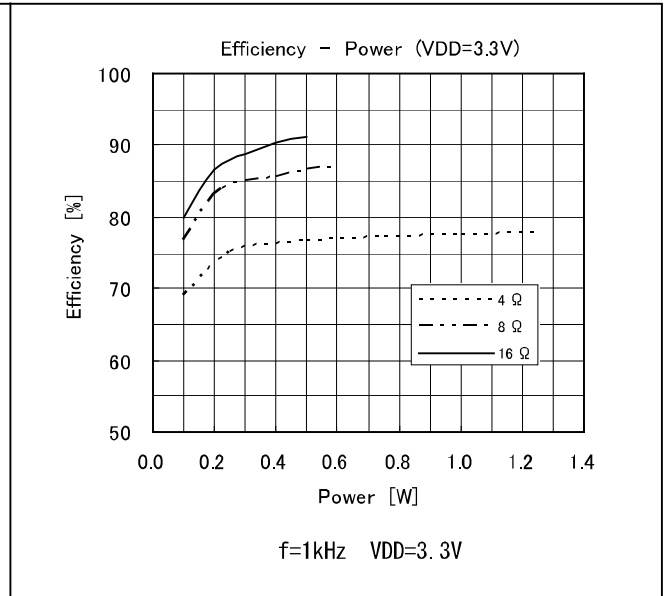
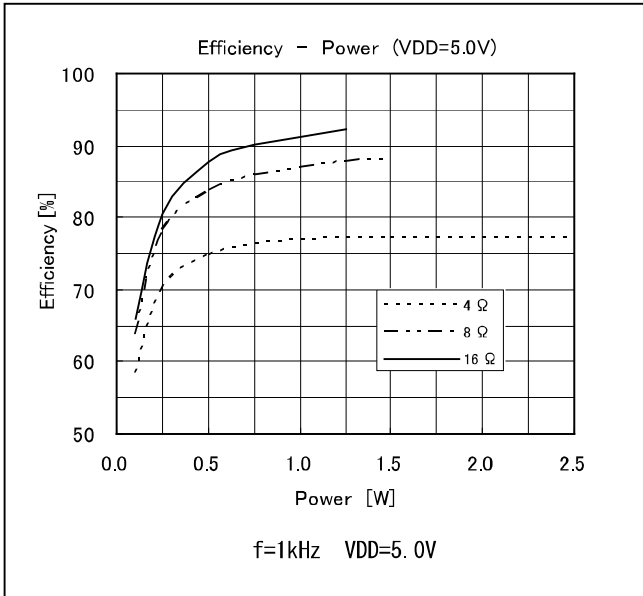

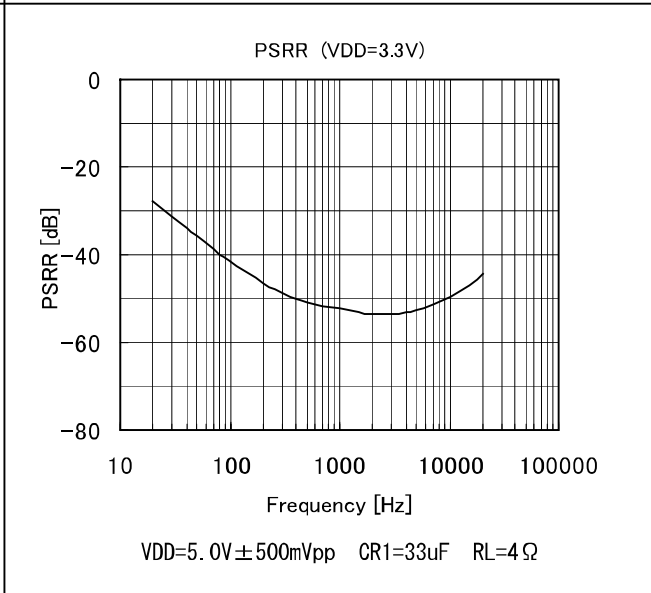
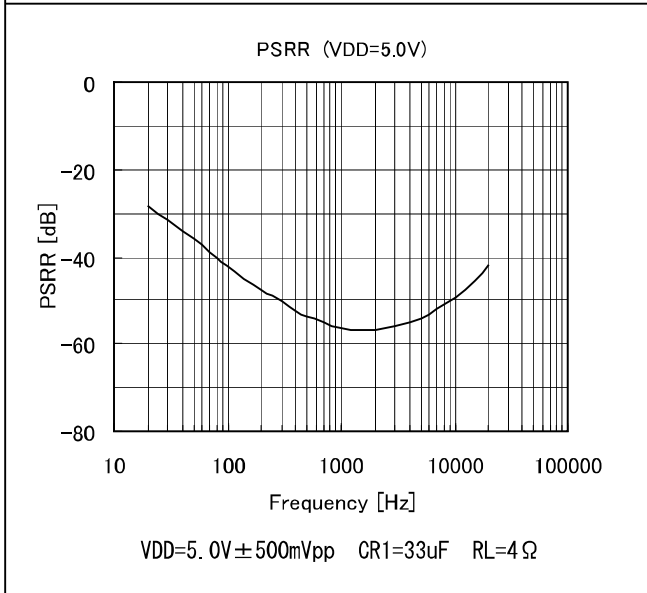
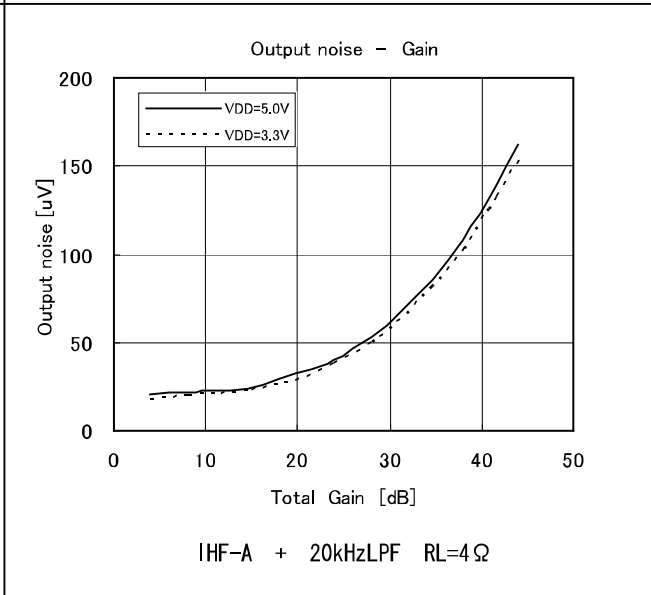
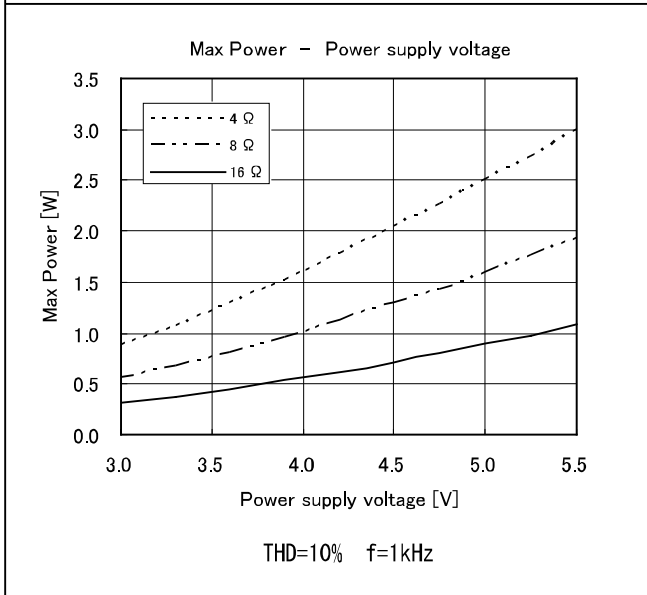
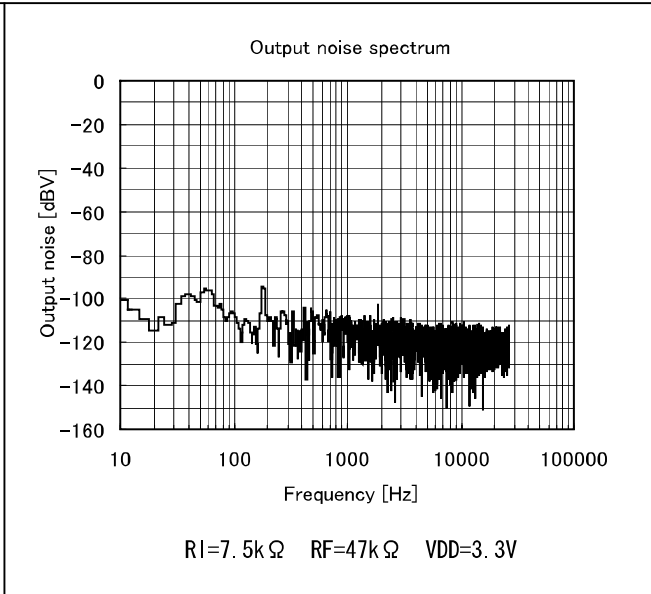
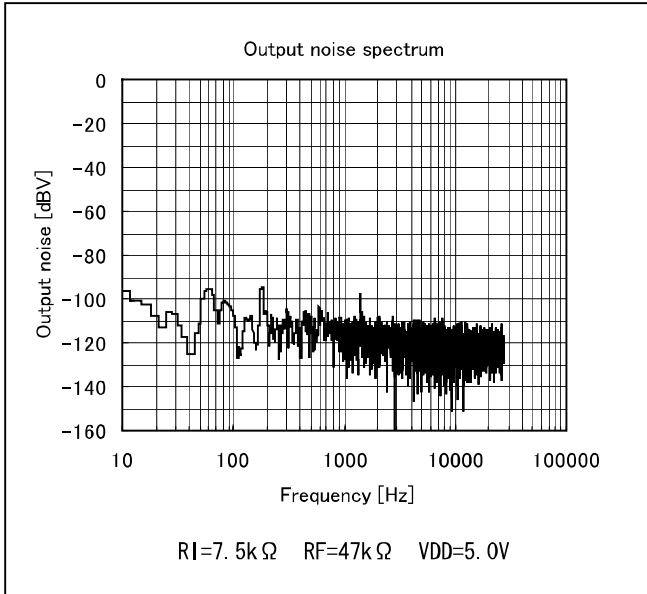

YDA131



External dimensions of package

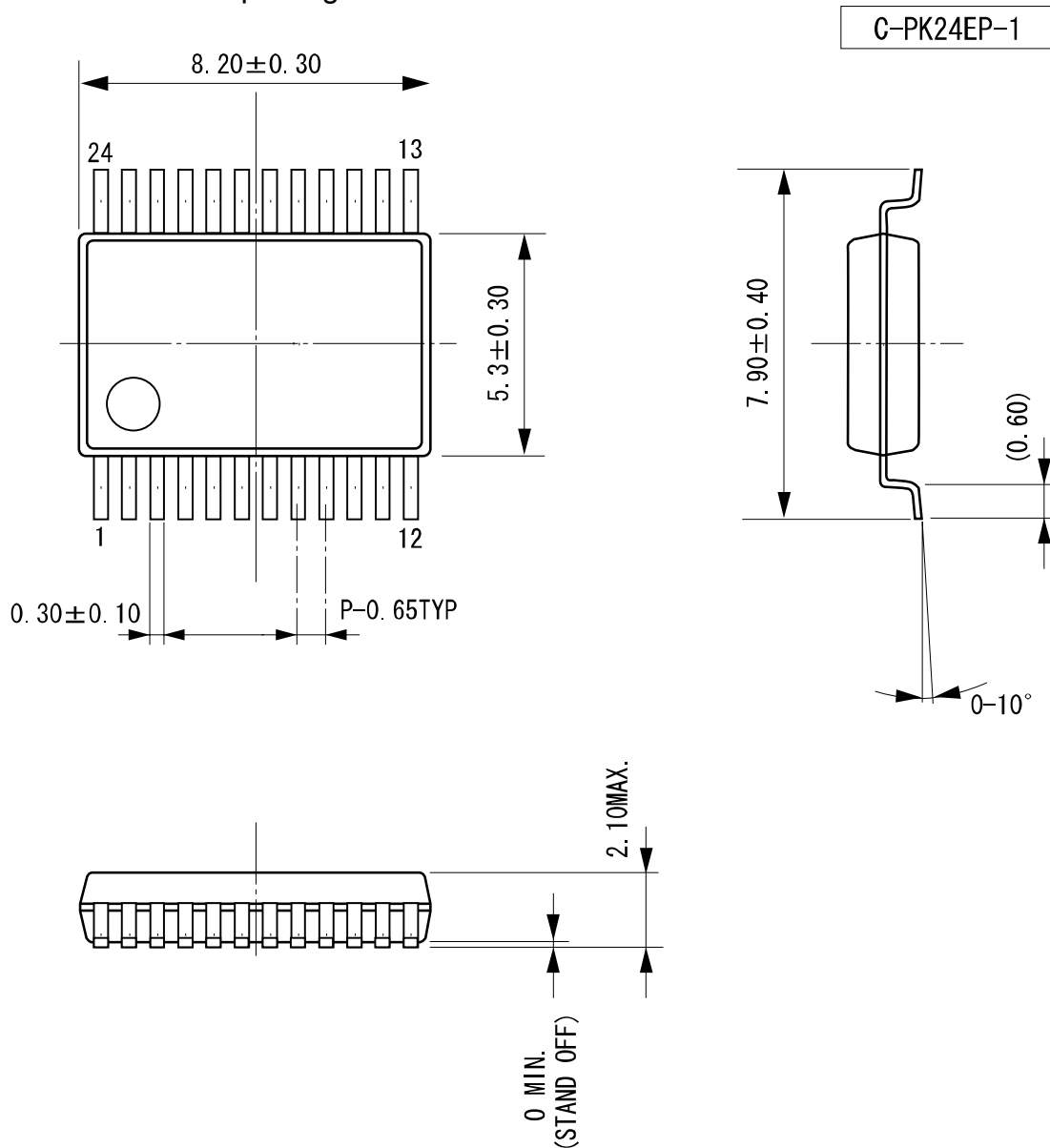

端子厚さ : 0.20 ± 0.10 or 0.22 ± 0.10
(LEAD THICKNESS)

カッコ内の寸法値は参考値とする。
モールド外形寸法はバリを含まない。
単位 (UNIT) : mm (millimeters)

The figure in the parenthesis ()
should be used as a reference.
Plastic body dimensions do not
include burr of resin.
UNIT: mm

注) 表面実装LSIは、保管条件、及び半田付けについての特別な配慮が必要です。
詳しくはヤマハ代理店までお問い合わせください。

Note: The storage and soldering of LSIs for surface mounting need special consideration.
For detailed information, please contact your local Yamaha agent.

IMPORTANT NOTICE

1. YAMAHA RESERVES THE RIGHT TO MAKE CHANGES TO ITS PRODUCTS AND TO THIS DOCUMENT WITHOUT NOTICE. THE INFORMATION CONTAINED IN THIS DOCUMENT HAS BEEN CAREFULLY CHECKED AND IS BELIEVED. HOWEVER, YAMAHA SHALL ASSUME NO RESPONSIBILITIES FOR INACCURACIES AND MAKE NO COMMITMENT TO UPDATE OR TO KEEP CURRENT THE INFORMATION CONTAINED IN THIS DOCUMENT.
2. THESE YAMAHA PRODUCTS ARE DESIGNED ONLY FOR COMMERCIAL AND NORMAL INDUSTRIAL APPLICATIONS, AND ARE NOT SUITABLE FOR OTHER USES, SUCH AS MEDICAL LIFE SUPPORT EQUIPMENT, NUCLEAR FACILITIES, CRITICAL CARE EQUIPMENT OR ANY OTHER APPLICATION THE FAILURE OF WHICH COULD LEAD TO DEATH, PERSONAL INJURY OR ENVIRONMENTAL OR PROPERTY DAMAGE. USE OF THE PRODUCTS IN ANY SUCH APPLICATION IS AT THE CUSTOMER'S OWN RISK AND EXPENSE.
3. YAMAHA SHALL ASSUME NO LIABILITY FOR INCIDENTAL, CONSEQUENTIAL OR SPECIAL DAMAGES OR INJURY THAT MAY RESULT FROM MISAPPLICATION OR IMPROPER USE OR OPERATION OF THE PRODUCT.
4. YAMAHA MAKES NO WARRANTY OR REPRESENTATION THAT THE PRODUCTS ARE SUBJECT TO INTELLECTUAL PROPERTY LICENSE FROM YAMAHA OR ANY THIRD PARTY, AND YAMAHA MAKES NO WARRANTY OR REPRESENTATION OF NON-INFRINGEMENT WITH RESPECT TO THE PRODUCTS. YAMAHA SPECIFICALLY EXCLUDES ANY LIABILITY TO THE CUSTOMER OR ANY THIRD PARTY ARISING FROM OR RELATED TO THE PRODUCTS INFRINGEMENT OF ANY THIRD PARTY'S INTELLECTUAL PROPERTY RIGHTS, INCLUDING THE PATENT, COPYRIGHT, TRADEMARK OR TRADE SECRET RIGHTS OF ANY THIRD PARTY.
5. EXAMPLES OF USE DESCRIBED HEREIN ARE MERELY TO INDICATE THE CHARACTERISTICS AND PERFORMANCE OF PRODUCTS. YAMAHA SHALL ASSUME NO RESPONSIBILITY FOR ANY INTELLECTUAL PROPERTY CLAIMS OR OTHER PROBLEMS THAT MAY RESULT FROM APPLICATIONS BASED ON THE EXAMPLES DESCRIBED HEREIN. YAMAHA MAKES NO WARRANTY WITH RESPECT TO THE PRODUCTS, EXPRESS OR IMPLIED, INCLUDING, BUT NOT LIMITED TO THE WARRANTIES OF MERCHANTABILITY, FITNESS FOR A PARTICULAR USE AND TITLE.
6. YAMAHA MAKES EVERY EFFORT TO IMPROVE THE QUALITY AND RELIABILITY OF ITS PRODUCTS. HOWEVER, ALL SEMICONDUCTOR PRODUCTS FAIL WITH SOME PROBABILITY. THEREFORE, YAMAHA REQUIRES THAT SUFFICIENT CARE BE GIVEN TO ENSURING SAFE DESIGN IN CUSTOMER PRODUCTS SUCH AS REDUNDANT DESIGN, ANTI-CONFLAGRATION DESIGN, AND DESIGN FOR PREVENTING MALFUNCTION IN ORDER TO PREVENT ACCIDENTS RESULTING IN INJURY OR DEATH, FIRE OR OTHER SOCIAL DAMAGE FROM OCCURRING AS A RESULT OF PRODUCT FAILURE.
7. INFORMATION DESCRIBED IN THIS DOCUMENT: APPLICATION CIRCUITS AND ITS CONSTANTS AND CALCULATION FORMULAS, PROGRAMS AND CONTROL PROCEDURES ARE PROVIDED FOR THE PURPOSE OF EXPLAINING TYPICAL OPERATION AND USAGE. THEREFORE, PLEASE EVALUATE THE DESIGN SUFFICIENTLY AS WHOLE SYSTEM UNDER THE CONSIDERATION OF VARIOUS EXTERNAL OR ENVIRONMENTAL CONDITIONS AND DETERMINE THEIR APPLICATION AT THE CUSTOMER'S OWN RISK. YAMAHA SHALL ASSUME NO RESPONSIBILITY FOR CLAIMS, DAMAGES, COSTS AND EXPENSES CAUSED BY THE CUSTOMER OR ANY THIRD PARTY, OWING TO THE USE OF THE ABOVE INFORMATION.

Notice The specifications of this product are subject to improvement changes without prior notice.

AGENT

YAMAHA CORPORATION

Address inquiries to:
Semiconductor Sales & Marketing Department

- Head Office 203, Matsunokijima, Toyooka-mura
Iwata-gun, Shizuoka-ken, 438-0192, Japan
Tel. +81-539-62-4918 Fax. +81-539-62-5054
- Tokyo Office 2-17-11, Takanawa, Minato-ku,
Tokyo, 108-8568, Japan
Tel. +81-3-5488-5431 Fax. +81-3-5488-5088
- Osaka Office 3-12-12, Minami Senba, Chuo-ku,
Osaka City, Osaka, 542-0081, Japan
Tel. +81-6-6252-6221 Fax. +81-6-6252-6229