

YOUDA INTEGRATED CIRCUIT

YD1117

**LOW DROP FIXED AND ADJUSTABLE
POSITIVE VOLTAGE REGULATORS—YD1117**

DESCRIPTION

The YD1117 is a LOW DROP Voltage Regulator able to provide up to 800mA of Output Current, available even in adjustable version($V_{ref}=1.25V$).

FEATURES

- *Low dropout voltage (1V typ)
- *2.85V Device performances are suitable for scsi-2 active termination
- *Output current up to 800mA
- *Fixed output voltage of :2.5V, 2.85V, 3.0V, 3.3V, 5.0V
- *Adjustable version availability ($V_{ref}=1.25V$)
- *Internal current and thermal limit
- *Available in $\pm 1%$ (at 25°C)and 2% in all temperature range
- *Supply voltage rejection : 75dB(TYP)

BLOCK DIAGRAM

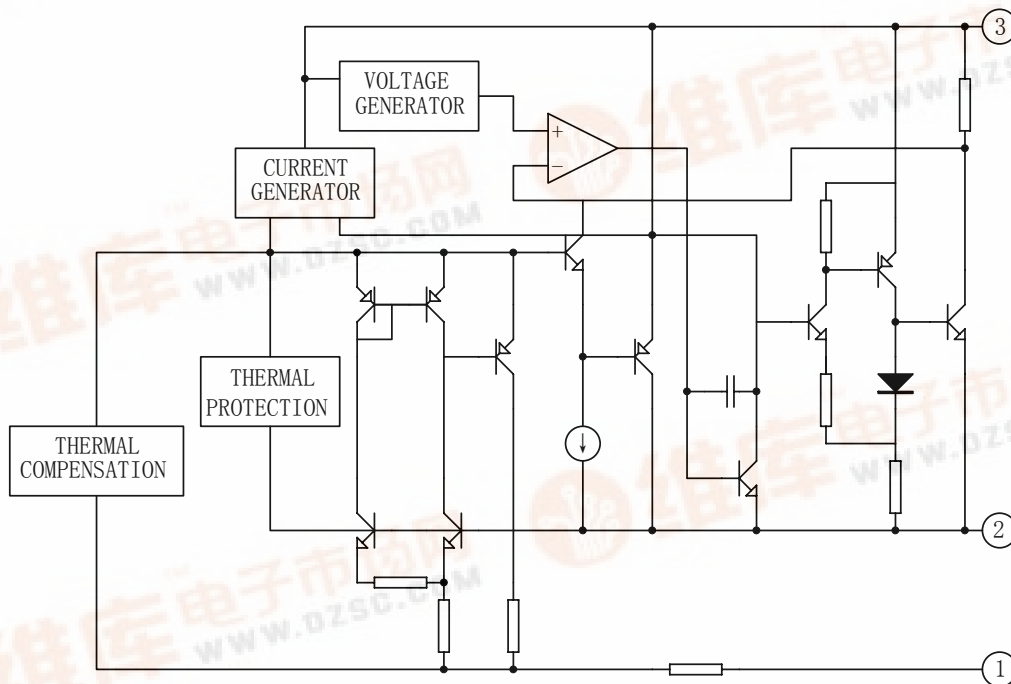

WuXi YouDa Electronics Co., Ltd

Add: No.5 Xijin Road, National Hi-Tech Industrial Development Zone, Wuxi Jiangsu China

Tel: 86-510-85205117 86-510-85205106 Fax: 86-510-85205110 Website: www.e-youda.com

SHENZHEN OFFICE Tel: 86-755-83740369 Fax: 86-755-83741418



ABSOLUTE MAXIMUM RATINGS (T_{amb}=25℃)

PARAMETER	SYMBOL	VALUE	UNIT
DC Input Voltage	V _{IN}	15	V
Power Dissipation	P _{tot}	12	W
Storage Temperature Range	T _{sty}	-40 to 150	℃
Operating Junction Temperature Range	T _{op}	0 to 125	℃

ELECTRICAL CHARACTERISTICS FOR YD1117#25

(refer to the test circuits, T_j=0 to 125℃, C_o=10 μ F Unless otherwise specified)

PARAMETER	SYMBOL	TEST CONDITIONS	MIN	TYP	MAX	UNIT
Output Voltage	V _o	V _{in} =4.5V, I _o =10mA, T _j =25℃	2.475	2.5	2.525	V
Output Voltage	V _o	I _o =0 to 800mA, V _{in} =3.9 to 10V	2.45		2.55	V
Line Regulation	ΔV _o	V _{in} =3.9 to 10V, I _o =0mA		1	6	mV
Load Regulation	ΔV _o	V _{in} =3.9V, I _o =0 to 800mA		1	10	mV
Temperature Stability	ΔV _o			0.5		%
Long Term Stability	ΔV _o	1000hrs T _j =125℃		0.3		%
Operating Input Voltage	V _{in}	I _o =100mA			15	V
Quiescent Current	I _d	V _{in} ≤ 10V		5	10	mA
Output Current	I _o	V _{in} =7.5V, T _j =25℃	800	950	1200	mA
Output Noise Voltage	e _N	B=10Hz to 10KHz, T _j =25℃		100		μ V
Supply Voltage Rejection	SVR	I _o =40mA, f=120Hz, T _j =25℃	60	75		dB
		V _{in} =5.85V, V _{ripple} =1V _{pp}				
Dropout Voltage	V _d	I _o =100mA		1	1.1	V
		I _o =500mA		1.05	1.15	V
		I _o =800mA		1.10	1.2	V
Thermal Regulation		T _{amb} =25℃ 30ms Pulse		0.01	0.1	%/W

ELECTRICAL CHARACTERISTICS FOR YD1117#28

(refer to the test circuits, T_j=0 to 125℃, C_o=10 μ F Unless otherwise specified)

PARAMETER	SYMBOL	TEST CONDITIONS	MIN	TYP	MAX	UNIT
Output Voltage	V _o	V _{in} =4.85V, I _o =10mA, T _j =25℃	2.82	2.85	2.88	V
Output Voltage	V _o	I _o =0 to 800mA, V _{in} =4.25 to 10V	2.79		2.91	V
Line Regulation	ΔV _o	V _{in} =4.25 to 10V, I _o =0mA		1	6	mV
Load Regulation	ΔV _o	V _{in} =4.25V, I _o =0 to 800mA		1	10	mV
Temperature Stability	ΔV _o			0.5		%
Long Term Stability	ΔV _o	1000hrs T _j =125℃		0.3		%

Operating Input Voltage	V _{in}	I _o =100mA			15	V
Quiescent Current	I _d	V _{in} ≤10V		5	10	mA
Output Current	I _o	V _{in} =7.85V, T _j =25°C	800	950	1200	mA
Output Noise Voltage	e _N	B=10Hz to 10KHz, T _j =25°C		100		μV
Supply Voltage Rejection	SVR	I _o =40mA, f=120Hz, T _j =25°C	60	75		dB
		V _{in} =5.85V, V _{ripple} =1V _{pp}				
Dropout Voltage	V _d	I _o =100mA		1	1.1	V
		I _o =500mA		1.05	1.15	V
		I _o =800mA		1.10	1.2	V
Thermal Regulation		T _{amb} =25°C 30ms Pulse		0.01	0.1	%/W

ELECTRICAL CHARACTERISTICS FOR YD1117#30

(refer to the test circuits, T_j=0 to 125°C, C_o=10 μF Unless otherwise specified)

PARAMETER	SYMBOL	TEST CONDITIONS	MIN	TYP	MAX	UNIT
Output Voltage	V _o	V _{in} =5V, I _o =10mA, T _j =25°C	2.97	3	3.03	V
Output Voltage	V _o	I _o =0 to 800mA, V _{in} =4.5 to 10V	2.94		3.06	V
Line Regulation	ΔV _o	V _{in} =4.5 to 12V, I _o =0mA		1	6	mV
Load Regulation	ΔV _o	V _{in} =4.5V, I _o =0 to 800mA		1	10	mV
Temperature Stability	ΔV _o			0.5		%
Long Term Stability	ΔV _o	1000hrs T _j =125°C		0.3		%
Operating Input Voltage	V _{in}	I _o =100mA			15	V
Quiescent Current	I _d	V _{in} ≤12V		5	10	mA
Output Current	I _o	V _{in} =8V, T _j =25°C	800	950	1200	mA
Output Noise Voltage	e _N	B=10Hz to 10KHz, T _j =25°C		100		MV
Supply Voltage Rejection	SVR	I _o =40mA f=120Hz, T _j =25°C, V _{in} =6V, V _{ripple} =1V _{pp}	60	75		dB
Dropout Voltage	V _d	I _o =100mA		1	1.1	V
		I _o =500mA		1.05	1.15	V
		I _o =800mA		1.10	1.2	V
Thermal Regulation		T _{amb} =25°C 30ms Pulse		0.01	0.1	%/W

ELECTRICAL CHARACTERISTICS FOR YD1117#33

(refer to the test circuits, T_j=0 to 125°C, C_o=10 μF Unless otherwise specified)

PARAMETER	SYMBOL	TEST CONDITIONS	MIN	TYP	MAX	UNIT
Output Voltage	V _o	V _{in} =5.3V, I _o =10mA, T _j =25°C	3.267	3.3	3.333	V

Output Voltage	V_o	$I_o=0$ to 800mA, $V_{in}=4.75$ to 10V	3.235		3.365	V
Line Regulation	ΔV_o	$V_{in}=4.75$ to 15V, $I_o=0$ mA		1	6	mV
Load Regulation	ΔV_o	$V_{in}=4.75$ V, $I_o=0$ to 800mA		1	10	mV
Temperature Stability	ΔV_o			0.5		%
Long Term Stability	ΔV_o	1000hrs $T_j=125^\circ\text{C}$		0.3		%
Operating Input Voltage	V_{in}	$I_o=100$ mA			15	V
Quiescent Current	I_d	$V_{in}\leq 15$ V		5	10	mA
Output Current	I_o	$V_{in}=8.3$ V, $T_j=25^\circ\text{C}$	800	950	1200	mA
Output Noise Voltage	eN	B=10Hz to 10KHz, $T_j=25^\circ\text{C}$		100		μ V
Supply Voltage Rejection	SVR	$I_o=40$ mA, $f=120$ Hz, $T_j=25^\circ\text{C}$	60	75		dB
		$V_{in}=6.3$ V, $V_{ripple}=1$ Vpp				
Dropout Voltage	V_d	$I_o=100$ mA		1	1.1	V
		$I_o=500$ mA		1.05	1.15	V
		$I_o=800$ mA		1.10	1.2	V
Thermal Regulation		$T_{amb}=25^\circ\text{C}$ 30ms Pulse		0.01	0.1	%/W

ELECTRICAL CHARACTERISTICS FOR YD1117#50

(refer to the test circuits, $T_j=0$ to 125°C , $C_o=10\ \mu\text{F}$ Unless otherwise specified)

PARAMETER	SYMBOL	TEST CONDITIONS	MIN	TYP	MAX	UNIT
Output Voltage	V_o	$V_{in}=7$ V, $I_o=10$ mA, $T_j=25^\circ\text{C}$	4.95	5	5.05	V
Output Voltage	V_o	$I_o=0$ to 800mA , $V_{in}=6.5$ to 15V	4.9		5.1	V
Line Regulation	ΔV_o	$V_{in}=6.5$ to 15V, $I_o=0$ mA		1	10	mV
Load Regulation	ΔV_o	$V_{in}=6.5$ V, $I_o=0$ to 800mA		1	15	mV
Temperature Stability	ΔV_o			0.5		%
Long Term Stability	ΔV_o	1000hrs $T_j=125^\circ\text{C}$		0.3		%
Operating Input Voltage	V_{in}	$I_o=100$ mA			15	V
Quiescent Current	I_d	$V_{in}\leq 15$ V		5	10	mA
Output Current	I_o	$V_{in}=10$ V, $T_j=25^\circ\text{C}$	800	950	1200	mA
Output Noise Voltage	eN	B=10Hz to 10kHz, $T_j=25^\circ\text{C}$		100		μ V
Supply Voltage Rejection	SVR	$I_o=40$ mA, $f=120$ Hz, $T_j=25^\circ\text{C}$	60	75		dB
		$V_{in}=8$ V, $V_{ripple}=1$ Vpp				
Dropout Voltage	V_d	$I_o=100$ mA		1	1.1	V
		$I_o=500$ mA		1.05	1.15	V
		$I_o=800$ mA		1.10	1.2	V
Thermal Regulation		$T_{amb}=25^\circ\text{C}$ 30ms Pulse		0.01	0.1	%/W

ELECTRICAL CHARACTERISTICS FOR YD1117(ADJUSTABLE)

(refer to the test circuits, $T_j=0$ to 125°C , $C_o=10\ \mu\text{F}$ Unless otherwise specified)

PARAMETER	SYMBOL	TEST CONDITIONS	MIN	TYP	MAX	UNIT
Reference Voltage	V_{ref}	$V_{in}-V_o=2\text{V}$, $b=10\text{mA}$, $T_j=25^{\circ}\text{C}$	1.238	1.25	1.262	V
Reference Voltage	V_{ref}	$I_o=10$ to 800mA , $V_{in}-V_o=1.4$ to 10V	1.225		1.275	V
Line Regulation	ΔV_o	$V_{in}-V_o=1.5$ to 13.75V , $I_o=10\text{mA}$		0.035	0.2	%
Load Regulation	ΔV_o	$V_{in}-V_o=3\text{V}$, $I_o=10$ to 800mA		0.1	0.4	%
Temperature Stability	ΔV_o			0.5		%
Long Term Stability	ΔV_o	1000hrs $T_j=125^{\circ}\text{C}$		0.3		%
Operating Input Voltage	V_{in}				15	V
Adjustment Pin Current	I_{adj}	$V_{in}\leq 15\text{V}$		60	120	μV
Adjustment Pin Current Change	ΔI_{adj}	$V_{in}-V_o=1.4$ to 10V , $I_o=10$ to 800mA		1	5	μV
Minimum Load Current	$I_o(\text{min})$	$V_{in}=15\text{V}$		2	5	mA
Output Current	I_o	$V_{in}-V_o=5\text{V}$, $T_j=25^{\circ}\text{C}$	800	950	1200	mA
Output Noise Voltage	eN	$B=10\text{Hz}$ to 10KHz , $T_j=25^{\circ}\text{C}$		0.003		%
Supply Voltage Rejection	SVR	$I_o=40\text{mA}$, $f=120\text{Hz}$, $T_j=25^{\circ}\text{C}$	60	75		dB
		$V_{in}-V_o=3\text{V}$, $V_{ripple}=1\text{Vpp}$				
Dropout Voltage	V_d	$I_o=100\text{mA}$		1	1.1	V
		$I_o=500\text{mA}$		1.05	1.15	V
		$I_o=800\text{mA}$		1.10	1.2	V
Thermal Regulation		$T_{amb}=25^{\circ}\text{C}$ 30ms Pulse		0.01	0.1	%/W

APPLICATION CIRCUIT

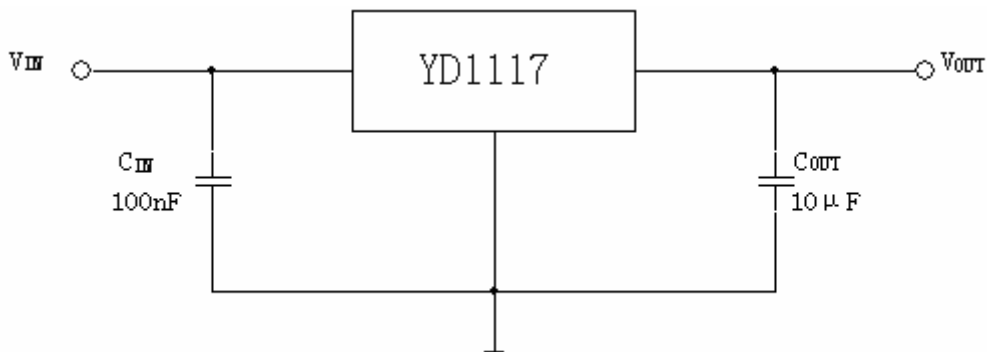

OUTLINE DRAWING

