

YOUDA INTEGRATED CIRCUIT

YD2073

DUAL CHANNEL POWER AMPLIFIER——YD2073

DESCRIPTION

The YD2073 is a monolithic integrated audio amplifier in a 8-pin plastic dual in line package. It is designed for mini cassette players and radios.

FEATURES

- *Wide operating supply voltage : $V_{CC}=1.8V\sim 5V$
- *Low crossover distortion
- *Low quiescent circuit current
- *Bridge/stereo configuration

BLOCK DIAGRAM

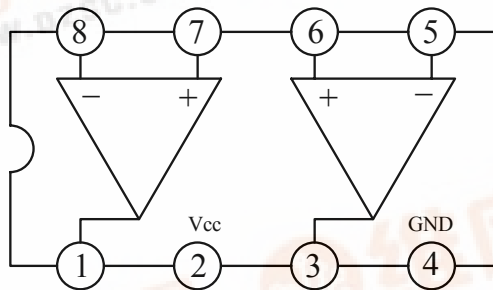

ABSOLUTE MAXIMUM RATINGS (Tamb=25°C)

PARAMETER	SYMBOL	VALUE	UNIT
Supply Voltage	Vcc	6	V
Output Peak Current	Iop	500	mA
Power Dissipation	P _D	300	mW
Operating Temperature	Topr	-20~+ 70	°C
Storage Temperature	Tstg	-40~+150	°C

WuXi YouDa Electronics Co., Ltd

Add: No.5 Xijin Road, National Hi-Tech Industrial Development Zone, Wuxi Jiangsu China

Tel: 86-510-85205117 86-510-85205106 Fax: 86-510-85205110 Website: www.e-youda.com

SHENZHEN OFFICE Tel: 86-755-83740369 Fax: 86-755-83741418



ELECTRICAL CHARACTERISTICS

(V_{cc}=3.0V, T_{amb}=25°C, all voltage referenced to GND, Unless otherwise specified)

STEREO APPLICATION

PARAMETER	SYMBOL	TEST CONDITIONS	MIN	TYP	MAX	UNIT
Operating Supply Voltage	V _{cc}		1.8		5	V
Quiescent Circuit Current	I _{ccq}			6	9	mA
Output Power	P _o	f=1kHz THD=10% V _{cc} =4.5V, R _L =32Ω	45	60		mW
		V _{cc} =3V, R _L =8Ω	45	60		
		V _{cc} =3V, R _L =4Ω	90	100		
Total Harmonic Distortion	THD	R _L =32Ω, P _O =30mW		0.2	1.0	%
		R _L =8Ω, P _O =30mW		0.2	1.0	
		R _L =4Ω, P _O =50mW		0.2	1.0	
Closed Loop Voltage Gain	G _v	f=1kHz	37	39	41	dB
Channel Balance	Δ G _v				±1	dB
Input Resistance	Z _i	f=1kHz	100			k Ω
Input Noise Voltage	V _{NI}	R _g =10k Ω BPF=20Hz~20kHz		2.5		μ V
Ripple Rejection	RR	f=100Hz	24	30		dB
Cross Talk	CT	f=1kHz		30		dB

BTL APPLICATION

PARAMETER	SYMBOL	TEST CONDITIONS		NIN	TYP	MAX	UNIT
Operating Supply Voltage	V_{CC}			1.8		5.0	V
Quiescent Circuit Current	I_{ccq}	$R_L = \infty$			6	9	mA
DC Output Balance	ΔV_O	$R_L = 8 \Omega$				± 50	mV
Output Power	P_o	$f=1\text{kHz}$ $\text{THD}=10\%$	$R_L=16 \Omega$	100	110		mW
			$R_L=8 \Omega$	190	200		mW
Total Harmonic Distortion	THD	$P_o=0.1\text{W}, R_L=8 \Omega, f=1\text{kHz}$			0.5	1.0	%
Closed Loop Voltage Gain	G_V	$f=1\text{kHz}$		37	39	41	dB
Input Resistance	Z_i	$f=1\text{kHz}$		100			k Ω
Input Noise Voltage	V_{N1}	$R_g=10\text{k} \Omega$ $\text{BPF}=20\text{Hz} \sim 20\text{kHz}$			3		μV
Ripple Rejection	RR	$f=100\text{Hz}$			40		dB
Power Bandwidth	BW	$R_L=8 \Omega, P_o=0.1\text{W}$			30		kHz

APPLICATION CIRCUIT

(1) YD2073 STEREO APPLICATION

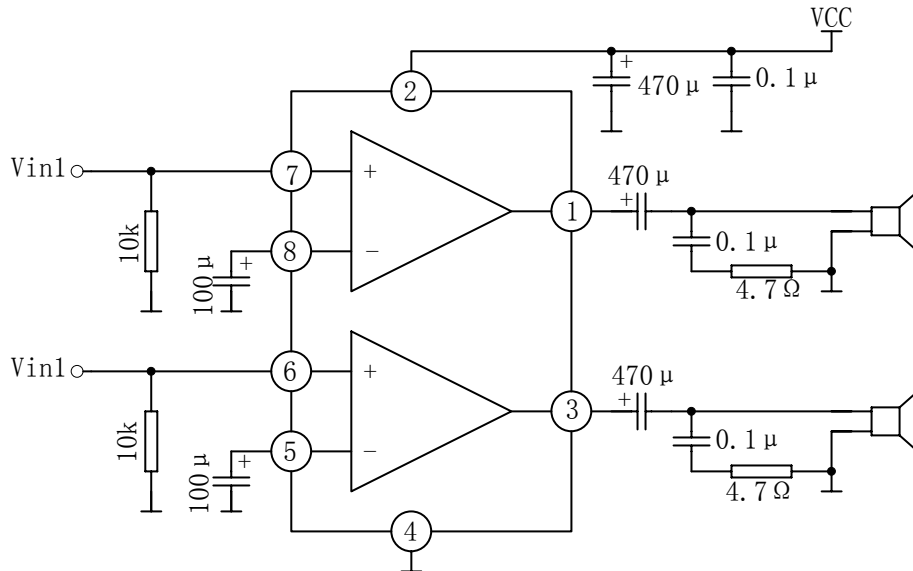

(2) YD2073 BTL APPLICATION

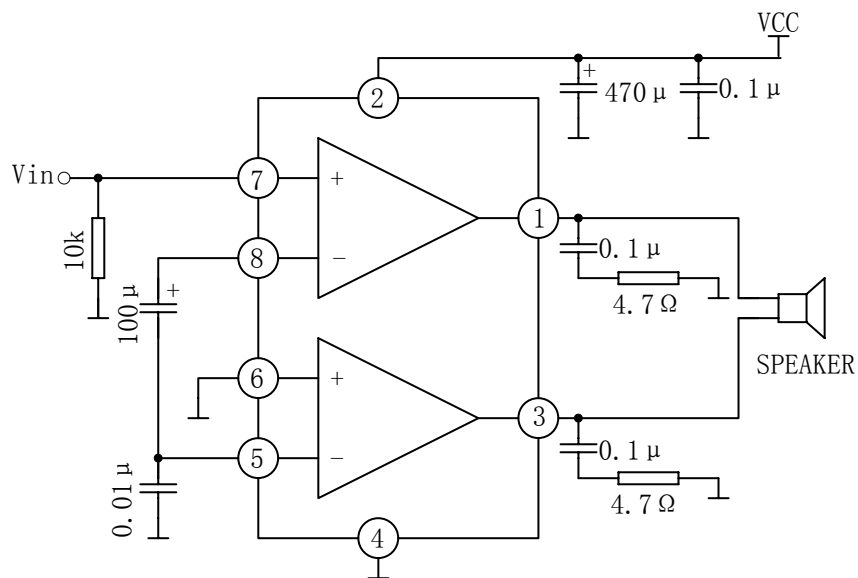

OUTLINE DRAWING

SOP-8

unit:mm

