

YAMAHA LSI

YSS235

(PTC2)

Pitch Changer 2

■ OUTLINE

YSS235(PTC2) is an audio signal processing LSI for the key control function of one channel. The key shift of -1800 cent to +1200 cent can be managed in each 100 cent. When the YSS235 shifts the key of -1200, -700 and +500 cent, human language can be got clearly.

As A/D, D/A converter and RAM for the key control are built-in, it is the best for the audio key shift of the analog signal equipments such as the tape-recorder and the VTR.

The amount of the key shift can be controlled even by the pulse input with the switch and the analog voltage input. Therefore, the microprocessor is unnecessary. It will be possible to develop and to make products in a shorter time at a lower cost.

■ FEATURES

- The YSS235 can control the amount of the key shift by 100 cent.
- Key control of -1800 cent to +1200 cent.
- When the key is shifted, human language can be got clearly.
- 14-bit floating A/D and D/A converter are built-in to cope with analog signal.
- Sampling frequency of the internal signal processing is 16kHz.
- Sampling frequency of A/D and D/A converter is 32kHz.
- RAM for the key control processing is built-in.
- Three selective modes for specifying the amount of the key shift.
 1. Analog voltage mode: Specification by pulse analog voltage.
 2. Switch pulse mode: Specification by pulse input from switch.
 3. Microprocessor pulse mode: Specification by pulse input from microprocessor.
- Master clock is 768kHz(48fs).
- 5V single power supply and Si-gate CMOS process.
- 16-pin DIP(YSS235-D) or 24-pin SOP(YSS235-M).

■ PIN CONFIGURATION

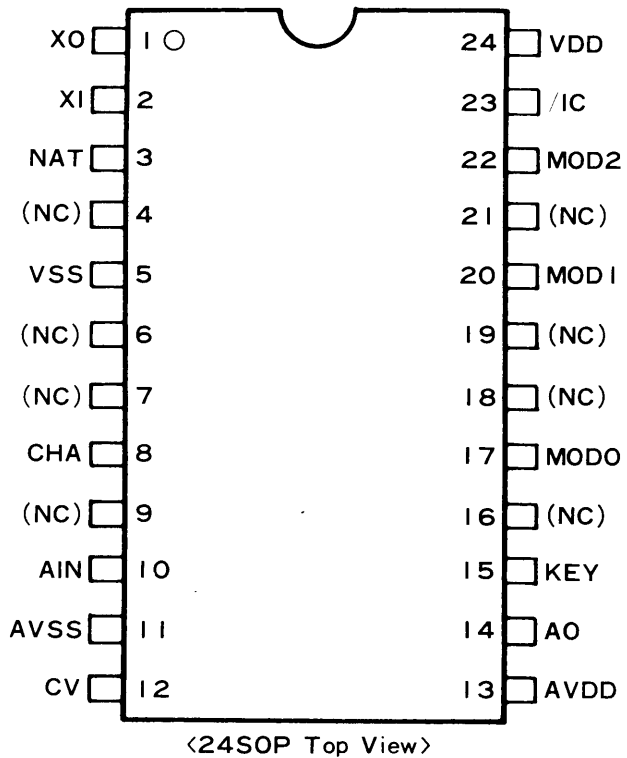
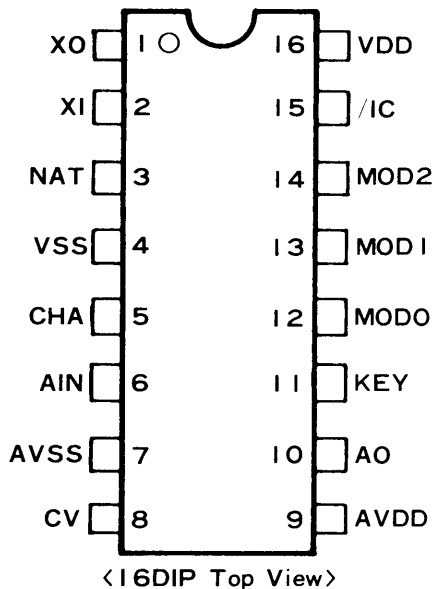

■ PIN DESCRIPTION

No.		Name	I/O	Function
16D	24S			
1	1	XO	O	Oscillator Connection Terminal
2	2	XI	I	Oscillator Connecting Terminal or External Clock Input (768kHz)
3	3	NAT	O	Key Shift Status Output ('H'=Non-Shift state)
4	5	VSS	—	Ground (Digital Block)
5	8	CHA	-A	Sample/Hold Capacitor Connecting Terminal for AIN signal
6	10	AIN	IA	Analog Audio Signal ADC Input
7	11	AVSS	-A	Ground (Analog Block)
8	12	CV	-A	Center Voltage terminal of Internal ADC
9	13	AVDD	-A	+5V Power Supply (Analog Block)
10	14	AO	OA	Analog Audio Signal DAC Output
11	15	KEY	IA	Key Shift Control Input
12	17	MOD0	I	Control Mode Select 0
13	20	MOD1	I	Control Mode Select 1
14	22	MOD2	I	Control Mode Select 2
15	23	/IC	Is	Initial Clear Input
16	24	VDD	—	+5V Power Supply (Digital Block)

(Note) Is; Schmitt-Trigger Input Terminal, A; Analog Terminal

■ BLOCK DIAGRAM

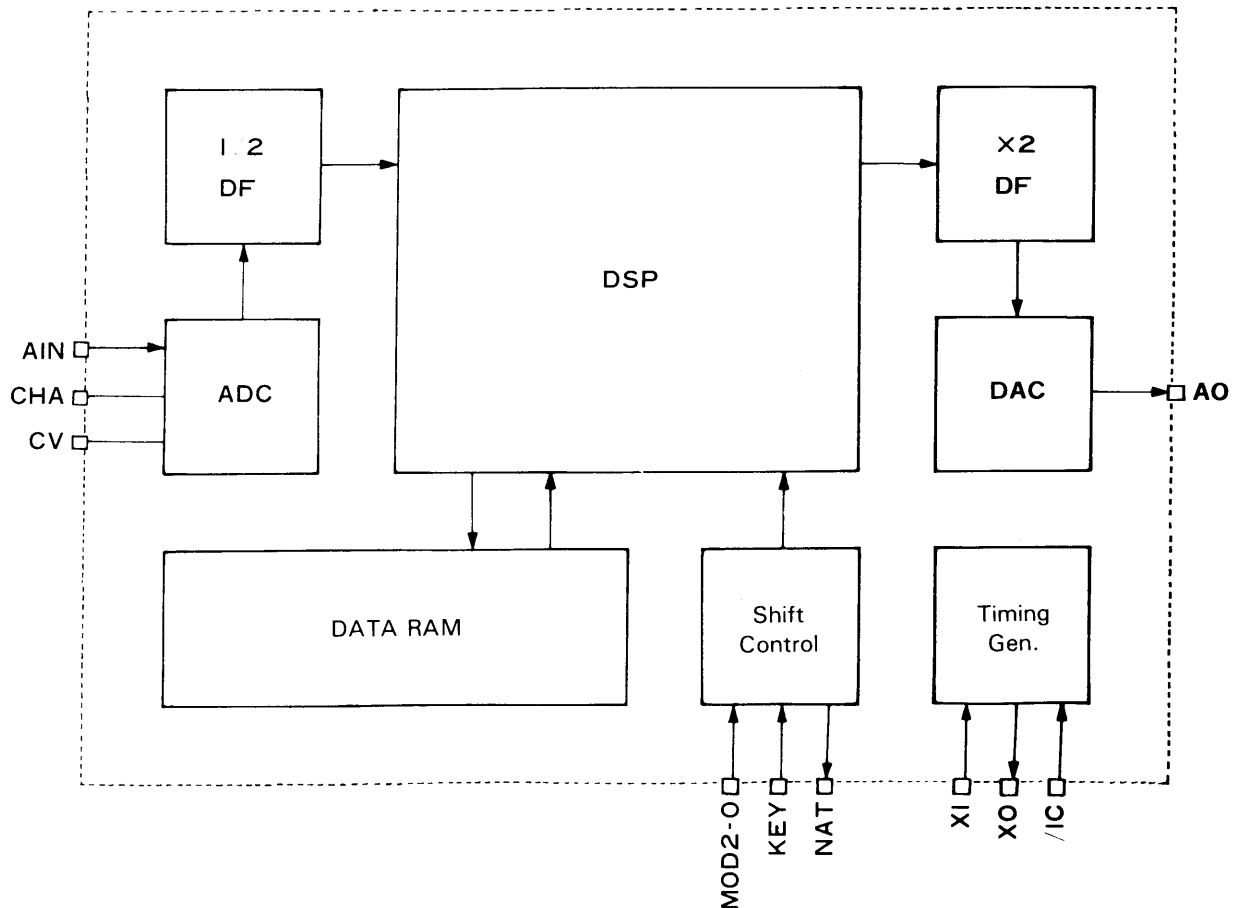

■ FUNCTION DESCRIPTION

1. Clocks XI, XO

Using XI and XO terminals, the oscillation circuit is composed.

The oscillation frequency is 768kHz(48fs).

It is also possible to input an external clock to the XI terminal.

2. Audio Signal I/O AIN, CHA, CV, AO

An analog audio signal is input from AIN terminal. The signal is A/D converted at 32kHz, is decimated to 16kHz with 1/2 under sampling filter, and is digital-processed.

Connect to CHA terminal the sample/hold capacitor for A/D conversion of AIN signal.

CV terminal indicates a center voltage of internal ADC. With a stabilization capacitor connected, bias the AIN signal by this voltage.

After digital key shift processing, audio signal is over-sampled to 32kHz with 2 times over-sampling filter and after D/A conversion, it is output from AO terminal.

With a sample/hold capacitor connected to AO terminal, execute the signal by the buffer with a high impedance input.

3. Key control KEY, MOD2-0, NAT

The method of specifying the amount of the key shift is selected with MOD2-MOD0 terminals. The KEY terminal is an input terminal to control the amount of the key shift. However, the input method is different depending on the specified mode.

The NAT terminal becomes 'H' when key is 'Non-shift' (It is displayed in every mode description as <NAT>).

When the key has changed, (All modes contain ± 0.0 cent), NAT the terminal becomes 'L'.

MOD2	MOD1	MOD0	Mode	Key Shift Range [cent]
H	H	H	Microprocessor Pulse Mode	-1800 ~ +1200 (by 100 cent)
H	H	L	Switch Pulse Mode 1	-1200 ~ +1200 (by 100 cent)
H	L	H	Switch Pulse Mode 2	-600 ~ +600 (by 100 cent)
H	L	L	Switch Pulse Mode 3	-400 ~ +400 (by 100 cent)
L	H	H	Analog Voltage Mode 1	-1800 ~ +1200 (by 100 cent)
L	H	L	Analog Voltage Mode 2	-1600 ~ +1200 (by 200 cent)

(1) Analog voltage mode

The KEY terminal voltage is divided into 32 levels between VDD-VSS, and keys are provided according to the KEY terminal voltage.

As for the analog voltage mode, there are two kinds and the shift resolution is different.

KEY Terminal Voltage [V]		Key Shift [cent]		KEY Terminal Voltage [V]		Key Shift [cent]	
* VDD	VDD=5.0	Mode 1	Mode 2	* VDD	VDD=5.0	Mode 1	Mode 2
32 ~ 31/32	5.00 ~ 4.84	+1200	+1200	16 ~ 15/32	2.50 ~ 2.34	-400	-400
31 ~ 30/32	4.84 ~ 4.69	+1100		15 ~ 14/32	2.34 ~ 2.19	-500	
30 ~ 29/32	4.69 ~ 4.53	+1000	+1000	14 ~ 13/32	2.19 ~ 2.03	-600	-600
29 ~ 28/32	4.53 ~ 4.38	+900		13 ~ 12/32	2.03 ~ 1.88	-700	
28 ~ 27/32	4.38 ~ 4.22	+800	+800	12 ~ 11/32	1.88 ~ 1.72	-800	-800
27 ~ 26/32	4.22 ~ 4.06	+700		11 ~ 10/32	1.72 ~ 1.56	-900	
26 ~ 25/32	4.06 ~ 3.91	+600	+600	10 ~ 9/32	1.56 ~ 1.41	-1000	-1000
25 ~ 24/32	3.91 ~ 3.75	+500		9 ~ 8/32	1.41 ~ 1.25	-1100	
24 ~ 23/32	3.75 ~ 3.59	+400	+400	8 ~ 7/32	1.25 ~ 1.09	-1200	-1200
23 ~ 22/32	3.59 ~ 3.44	+300		7 ~ 6/32	1.09 ~ 0.94	-1300	
22 ~ 21/32	3.44 ~ 3.28	+200	+200	6 ~ 5/32	0.94 ~ 0.78	-1400	-1400
21 ~ 20/32	3.28 ~ 3.13	+100		5 ~ 4/32	0.78 ~ 0.63	-1500	
20 ~ 19/32	3.13 ~ 2.97	± 0	± 0	4 ~ 3/32	0.63 ~ 0.47	-1600	-1600
19 ~ 18/32	2.97 ~ 2.81	-100		3 ~ 2/32	0.47 ~ 0.31	-1700	
18 ~ 17/32	2.81 ~ 2.66	-200	-200	2 ~ 1/32	0.31 ~ 0.16	-1800	<NAT>
17 ~ 16/32	2.66 ~ 2.50	-300		1 ~ 0/32	0.16 ~ 0.00	<NAT>	

(Note) <NAT>: The key becomes non-shift.

(2) Switch pulse mode

The key changes 100 cent by every pulse to KEY terminal according to the voltage level of the pulse.

The width of the pulse is required to be 32ms or more, and the pulse shorter than 32ms is disregarded.

As for the switch pulse mode, there are three kinds and the variable range of the key is different. The pulse which specifies more than the maximum variable range is disregarded.

KEY Terminal Voltage [V]	Operation	Maximum Variable Range		
		Mode 1	Mode 2	Mode 3
L3= VDD (VDD ~ 3/4 VDD)	No Change			
L2= 5/8 VDD (3/4 VDD ~ 2/4 VDD)	Key Shift Up (100 cent)	+6	+3	+2
L1= 3/8 VDD (2/4 VDD ~ 1/4 VDD)	Key Shift Down (100 cent)	-6	-	-2
L0= VSS (1/4 VDD ~ VSS)	Return to Non-shift <NAT>			

[Example]

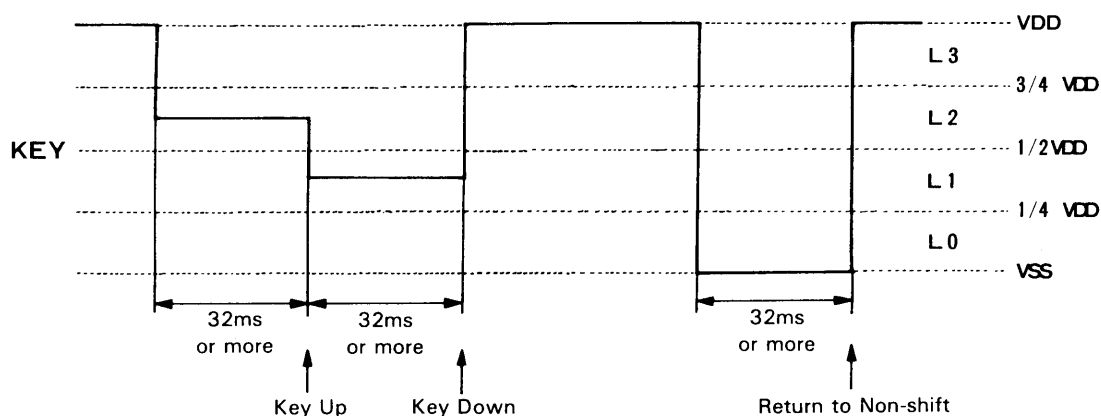

(3) Microprocessor pulse mode

The amount of the key shift is specified according to the number of the pulse input to KEY terminal.

Each code is identified by the number of the pulse inputs at intervals of 1ms or less, and the delimitation between codes by a pulse interval of 1ms or more. Set the width of the pulse as 1ms or less.

In this mode, unless 'one pulse' code is input to KEY terminal, actual key shift will not be executed.

Pulse Code	Operation
One Pulse	Execute
Two Pulse	Setting of Key Up (100 cent)
Three Pulse	Setting of Key Down (100 cent)
Four Pulse	Setting of Non shift <NAT>

[Example]

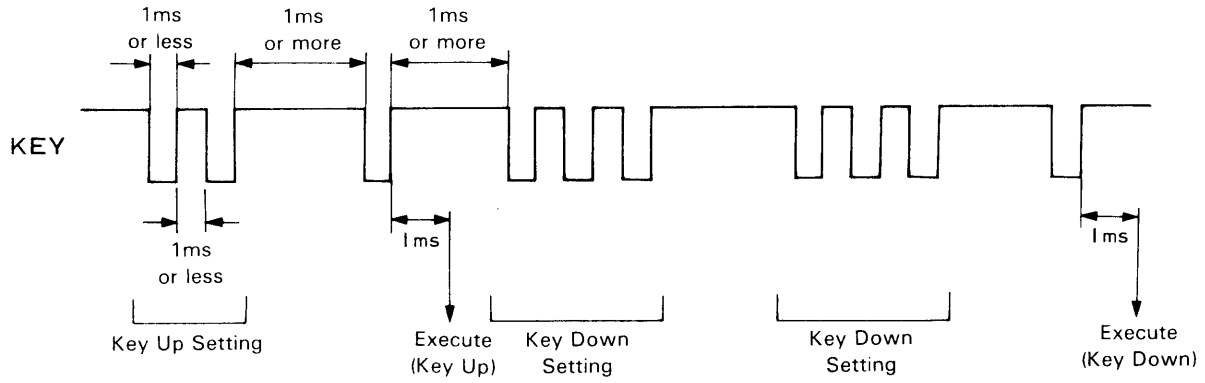

4. Reset /IC

It is necessary to reset this LSI when the power is turned on.

■ ELECTRICAL CHARACTERISTICS

1. Absolute Maximum Ratings

Parameter	Symbol	Rating	Unit
Power Supply Voltage	VDD	-0.5 ~ 7.0	V
Input Voltage	VI	-0.5 ~ VDD+0.5	V
Output Current	IO	-20 ~ 20	mA
Operating Temperature	Top	0 ~ 70	°C
Storage Temperature	Tstg	-50 ~ 125	°C

2. Recommended Operating Conditions

Parameter	Symbol	Min.	Typ.	Max.	Unit
Power Supply Voltage	VDD	4.5	5.0	5.5	V
Operating Temperature	Top	0	25	70	°C

3. DC Characteristics

Parameter	Symbol	Condition	Min.	Typ.	Max.	Unit
Power Supply Current	IDD	VDD=5.0V		9		mA
Input Voltage H Level	VIL	*1			0.3VDD	V
Input Voltage L Level	VIH	*1	0.7VDD			V
Input Leakage Current	ILI	*2			10	μA
Input Capacitance	CI	*1			8	pF
Output Voltage L Level	VOL	IOL=1.6mA, *3			0.4	V
Output Voltage H Level	VOH	IOH=-0.4mA, *3	VDD-0.4			V
Output Capacitance	CO	*3			10	pF

*1) Applicable to XI, MOD0, MOD1, MOD2, /IC terminals.

*2) Applicable to input terminals except analog terminals and pulled up terminals.

*3) Applicable to all output terminals except analog terminals.

4. AC Characteristics

Parameter	Symbol	Min.	Typ.	Max.	Unit
XIN Clock Frequency	fc	690	768	845	kHz
H Level Time	t _{hc}	390			ns
L Level Time	t _{lc}	390			ns
Rise Time	t _{rc}		50	200	ns
Fall Time	t _{fc}		50	200	ns
/IC Pulse Width	t _{icw}	13			μs

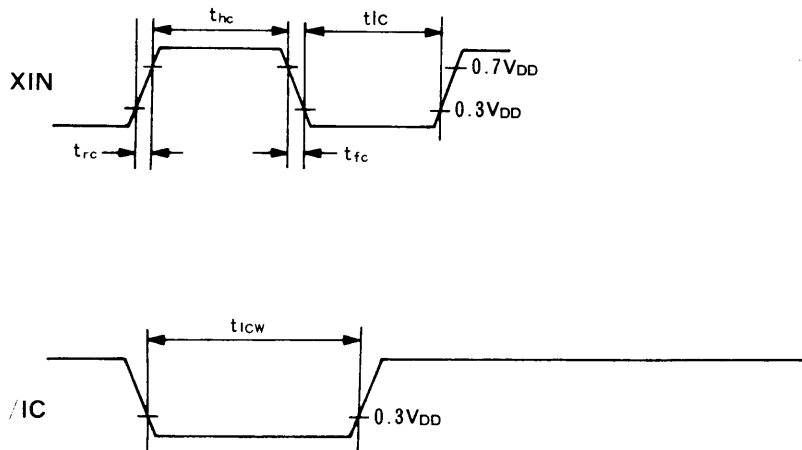

5. Analog Characteristics (VDD=5.0V, Top=25°C)

Parameter	Symbol	Condition	Min.	Typ.	Max.	Unit
Analog Input Voltage (1)	VIA1	AIN Terminal	0.05VDD		0.95VDD	V
Analog Input Voltage (2)	VIA2	KEY Terminal	0		VDD	V
Analog Output Voltage	VOA	AO Terminal	0.02VDD		0.98VDD	V
CV Center Voltage	VC	CV Terminal		0.5VDD		V
Total Harmonic Distortion	THD+N	1kHz, 0dB, *1 1kHz, -30dB, *1			1.0 1.5	% %
Signal to Noise Ratio	S/N	S=0dB, *1	75	80		dB

*1) 0dB=4.5Vpp, A/D → D/A through

EXTERNAL DIMENSIONS

● YSS222-D

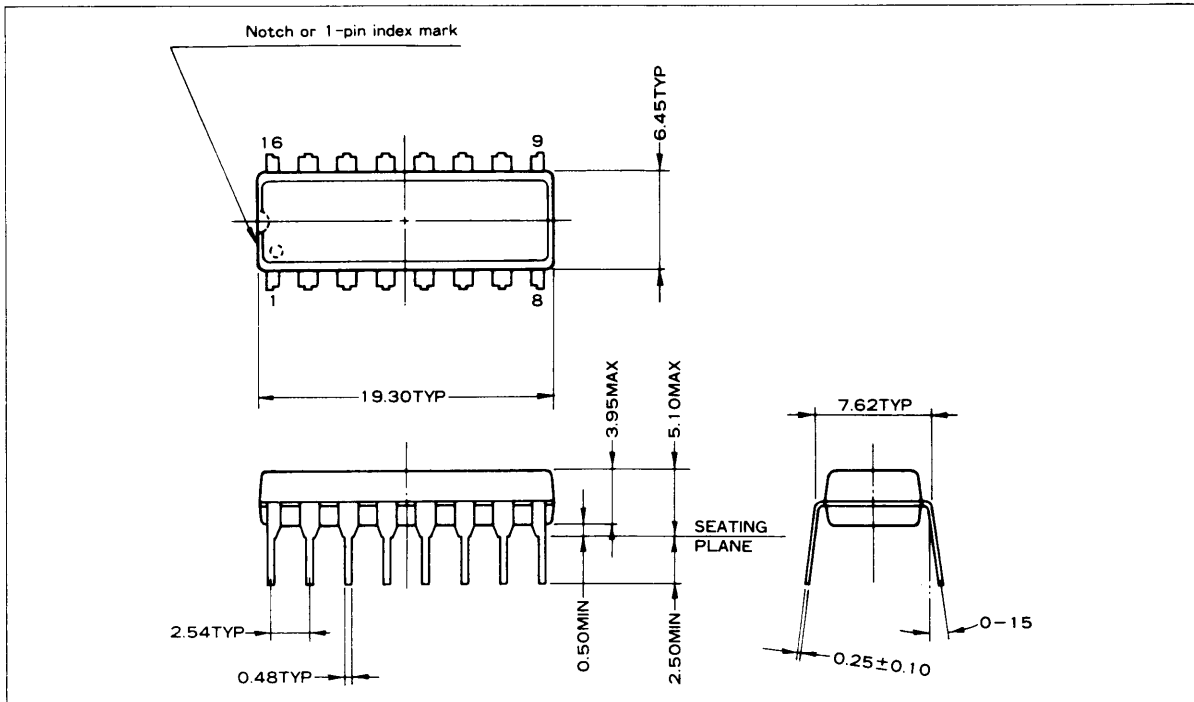

● YSS222-M

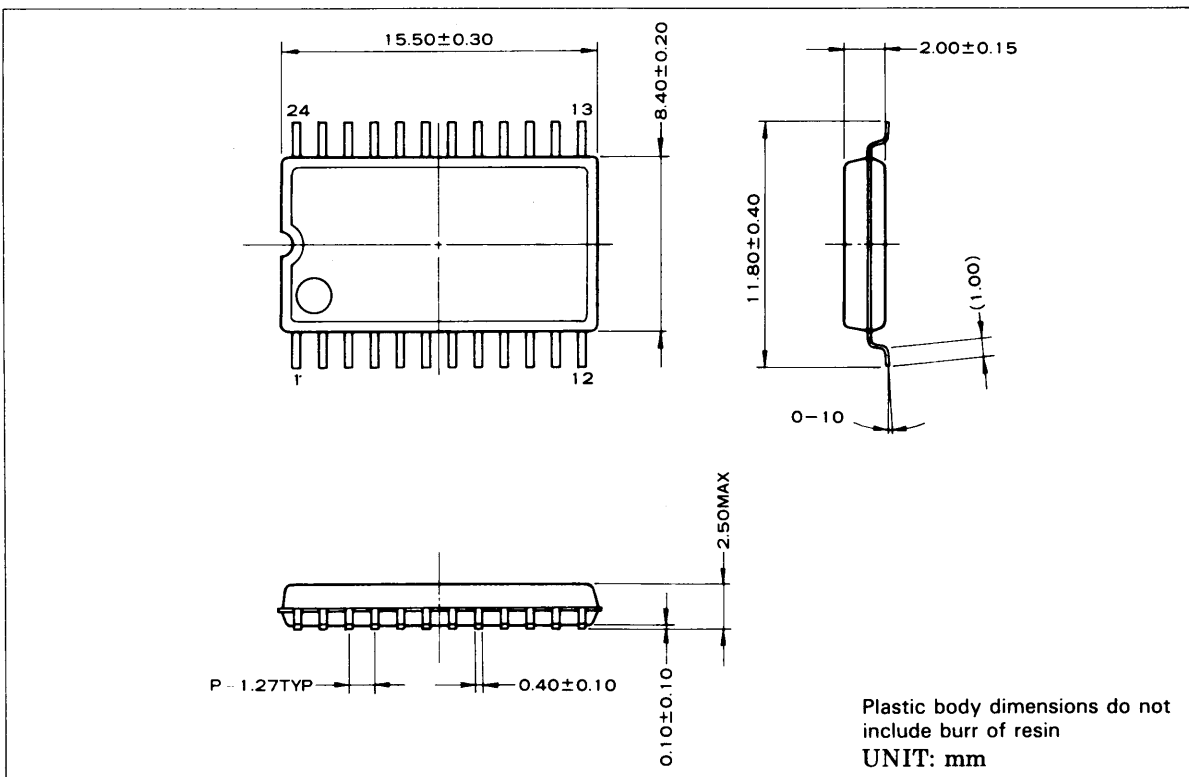

IMPORTANT NOTICE

1. Yamaha reserves the right to make changes to its Products and to this document without notice. The information contained in this document has been carefully checked and is believed to be reliable. However, Yamaha assumes no responsibilities for inaccuracies and makes no commitment to update or to keep current the information contained in this document.
2. These Yamaha Products are designed only for commercial and normal industrial applications, and are not suitable for other uses, such as medical life support equipment, nuclear facilities, critical care equipment or any other application the failure of which could lead to death, personal injury or environmental or property damage. Use of the Products in any such application is at the customer's sole risk and expense.
3. YAMAHA ASSUMES NO LIABILITY FOR INCIDENTAL, CONSEQUENTIAL OR SPECIAL DAMAGES OR INJURY THAT MAY RESULT FROM MISAPPLICATION OR IMPROPER USE OR OPERATION OF THE PRODUCTS.
4. YAMAHA MAKES NO WARRANTY OR REPRESENTATION THAT THE PRODUCTS ARE SUBJECT TO INTELLECTUAL PROPERTY LICENSE FROM YAMAHA OR ANYTHIRD PARTY, AND YAMAHA MAKES NO WARRANTY OR REPRESENTATION OF NON-INFRINGEMENT WITH RESPECT TO THE PRODUCTS. YAMAHA SPECIFICALLY EXCLUDES ANY LIABILITY TO THE CUSTOMER OR ANY THIRD PARTY ARISING FROM OR RELATED TO THE PRODUCTS' INFRINGEMENT OF ANY THIRD PARTY'S INTELLECTUAL PROPERTY RIGHTS, INCLUDING THE PATENT, COPYRIGHT, TRADEMARK OR TRADE SECRET RIGHTS OF ANY THIRD PARTY.
5. EXAMPLES OF USE DESCRIBED HEREIN ARE MERELY TO INDICATE THE CHARACTERISTICS AND PERFORMANCE OF YAMAHA PRODUCTS. YAMAHA ASSUMES NO RESPONSIBILITY FOR ANY INTELLECTUAL PROPERTY CLAIMS OR OTHER PROBLEMS THAT MAY RESULT FROM APPLICATIONS BASED ON THE EXAMPLES DESCRIBED HEREIN. YAMAHA MAKES NO WARRANTY WITH RESPECT TO THE PRODUCTS, EXPRESS OR IMPLIED, INCLUDING, BUT NOT LIMITED TO THE WARRANTIES OF MERCHANTABILITY, FITNESS FOR A PARTICULAR USE AND TITLE.

_____ AGENCY _____

YAMAHA CORPORATION

**Address inquiries to:
Semiconductor Sales & Marketing Department**

- Head Office 203, Matsunokijima, Toyooka-mura,
Iwata-gun, Shizuoka-ken, 438-0192
Tel. +81-539-62-4918 Fax. +81-539-62-5054
- Tokyo Office 2-17-11, Takanawa, Minato-ku,
Tokyo, 108-8568
Tel. +81-3-5488-5431 Fax. +81-3-5488-5088
- Osaka Office Namba Tsujimoto Nissei Bldg. 4F
1-13-17, Namba Naka, Naniwa-ku,
Osaka City, Osaka, 556-0011
Tel. +81-6-6633-3690 Fax. +81-6-6633-3691
- U.S.A. Office YAMAHA Systems Technology
100 Century Center Court, San Jose,
CA 95112
Tel. +1-408-467-2300 Fax. +1-408-437-8791