



ZL38015 Voice Processor

Data Sheet

A full Design Manual is available to qualified customers. To register, please send an email to VoiceProcessing@Zarlink.com.

June 2007

Features

- 100 MHz (200 MIPs) Zarlink voice processor with Butterfly hardware accelerator and breakpoint/interrupt controller
- On-board Data (26 Kbytes), Instruction (24 Kbytes) RAM and Boot (3 Kbytes) ROM
- 2048 tap Filter co-processor shared across up to 16 separate functions in 128 tap increments
- Primary PCM port supports TDM (ST BUS, GCI or McBSP framing) or SSI modes at bit rates of 128, 256, 512, 1024, 2048, 4096, 8192 or 16384 Kb/sec
- Separate slave (microcontroller) and master (Flash) SPI ports, maximum clock rate = 25 MHz
- Watchdog and 2 auxiliary timers
- 11 General Purpose Input/Output (GPIO) pins
- General purpose UART port
- Bootloadable for future Zarlink software upgrades
- External oscillator or crystal/ceramic resonator

Ordering Information

ZL38015QCG1 100 Pin LQFP Trays, Bake & Drypack

*Pb Free Matte Tin

-40°C to +85°C

- 1.2 V Core; 3.3 V IO with 5 V-tolerant inputs
- IEEE-1149.1 compatible JTAG port

Applications

- Wireless Local Loop base stations and controllers
- Voice telephony gateways
- Digital, VoIP based and wireless PBX systems
- Echo Canceller pools
- Customer Premise equipment
- Integrated access devices
- SOHO gateways

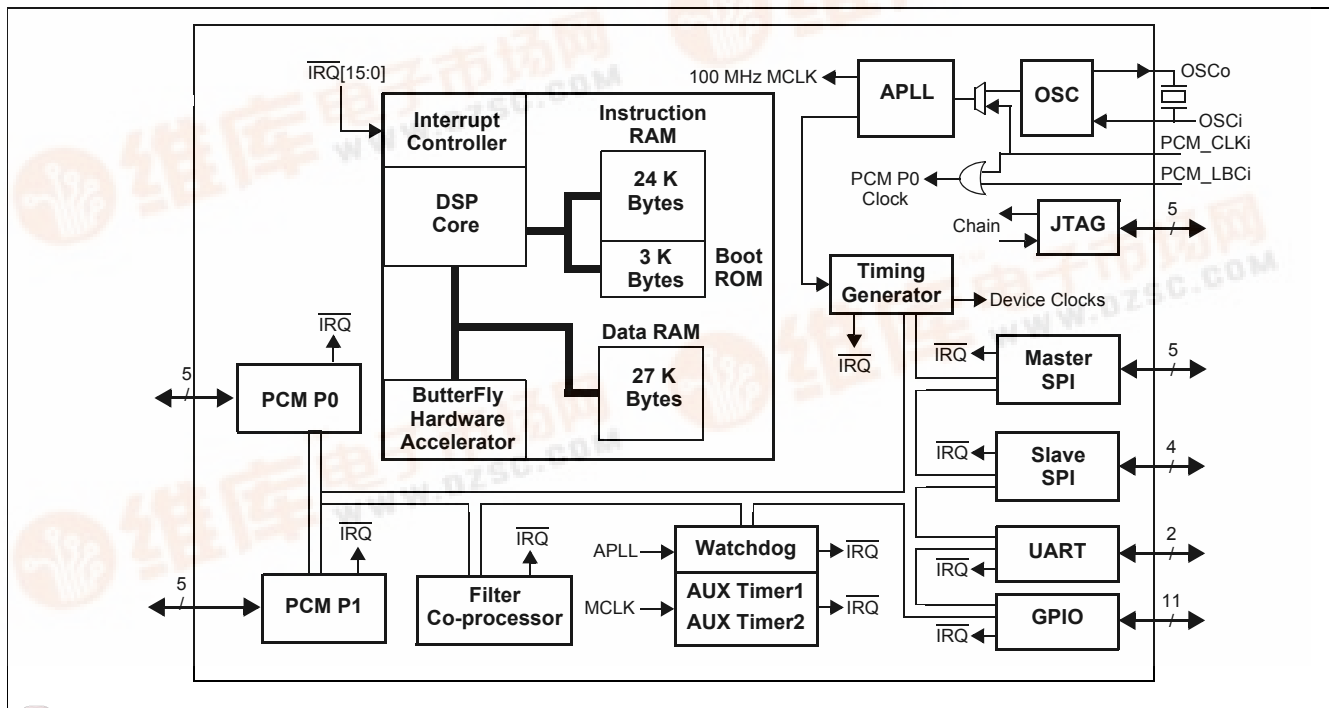

Figure 1 - Functional Block Diagram



Description

The ZL38015 is a four channel Voice-Processor hardware platform designed to support advanced voice and digital signal processing applications available from Zarlink Semiconductor. The ZL38015 platform integrates Zarlink's Voice Processor (ZVP) DSP Core with a number of internal peripherals including: 2 PCM ports, a 2048 tap Filter Co-processor, 2 Auxiliary Timers and a Watchdog Timer, 9 GPIO pins, UART, Slave SPI and Master SPI ports and a master/slave timing block.

The firmware products and manuals available at the release of this data sheet is the ZLS38233: 4 Channel Voice Echo Canceller (VEC) with integrated DTMF Transceiver (Tx/Rx). If these applications do not meet your requirements, please contact your local Zarlink Sales Office for the latest firmware releases.

1.0 Functional Description

The ZL38015 is a hardware platform designed to support advanced voice processing applications available from Zarlink Semiconductor. These applications are resident in external memory and are down-loaded by the ZL38015 resident boot code during initialization.

The firmware products and manuals available at the release of this data sheet is the ZLS38233: 4 Channel Voice Echo Canceller with DTMF Transceiver.

The ZL38015 platform integrates Zarlink's Voice Processor (ZVP) DSP Core with a number of internal peripherals. These peripherals include the following:

- Two PCM ports - ST BUS, GCI, McBSP or SSI operation
- A 2048 tap Filter Co-processor (LMS, FIR and FAP realizations)
- Two Auxiliary Timers and a Watchdog Timer
- 11 GPIO pins
- A UART interface
- A Slave SPI port and a Master SPI port
- A timing block that supports master and slave operation
- An IEEE - 1149.1 compatible JTAG port

The DSP Core can process up to four 8-bit voice channels, two 16-bit voice channels or two 8-bit and one 16-bit voice channel.



**For more information about all Zarlink products
visit our Web Site at
www.zarlink.com**

Information relating to products and services furnished herein by Zarlink Semiconductor Inc. or its subsidiaries (collectively "Zarlink") is believed to be reliable. However, Zarlink assumes no liability for errors that may appear in this publication, or for liability otherwise arising from the application or use of any such information, product or service or for any infringement of patents or other intellectual property rights owned by third parties which may result from such application or use. Neither the supply of such information or purchase of product or service conveys any license, either express or implied, under patents or other intellectual property rights owned by Zarlink or licensed from third parties by Zarlink, whatsoever. Purchasers of products are also hereby notified that the use of product in certain ways or in combination with Zarlink, or non-Zarlink furnished goods or services may infringe patents or other intellectual property rights owned by Zarlink.

This publication is issued to provide information only and (unless agreed by Zarlink in writing) may not be used, applied or reproduced for any purpose nor form part of any order or contract nor to be regarded as a representation relating to the products or services concerned. The products, their specifications, services and other information appearing in this publication are subject to change by Zarlink without notice. No warranty or guarantee express or implied is made regarding the capability, performance or suitability of any product or service. Information concerning possible methods of use is provided as a guide only and does not constitute any guarantee that such methods of use will be satisfactory in a specific piece of equipment. It is the user's responsibility to fully determine the performance and suitability of any equipment using such information and to ensure that any publication or data used is up to date and has not been superseded. Manufacturing does not necessarily include testing of all functions or parameters. These products are not suitable for use in any medical products whose failure to perform may result in significant injury or death to the user. All products and materials are sold and services provided subject to Zarlink's conditions of sale which are available on request.

Purchase of Zarlink's I²C components conveys a licence under the Philips I²C Patent rights to use these components in and I²C System, provided that the system conforms to the I²C Standard Specification as defined by Philips.

Zarlink, ZL and the Zarlink Semiconductor logo are trademarks of Zarlink Semiconductor Inc.

Copyright Zarlink Semiconductor Inc. All Rights Reserved.

TECHNICAL DOCUMENTATION - NOT FOR RESALE
