



ZL60113/4

12 x 3.125 Gbps Parallel Fiber Optic Link Transmitter and Receiver

Data Sheet

May 2007

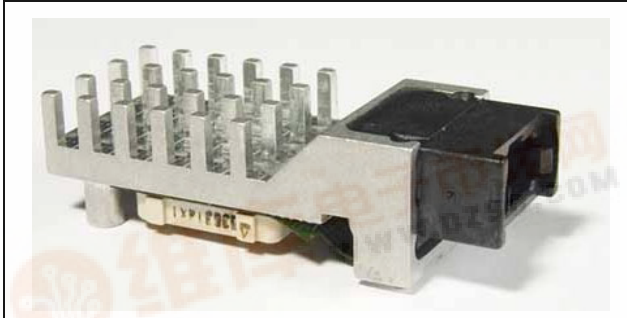

Ordering Information

ZL60113MLDA Parallel Fiber Transmitter
 ZL60114MLDA Parallel Fiber Receiver

ZL6011xMMDA Parallel Fiber Module with
 EMI gasket

0°C to +80°C

Features

- 12 parallel channels, total 37.5 Gbps capacity
- Data rate up to 3.125 Gbps per channel
- 850 nm VCSEL array
- Link reach 200 m with 50/125 μm 500 MHz·km fiber at 3.125 Gbps
- Channel BER better than 10⁻¹²
- Industry standard MPO/MTP™ ribbon fiber connector interface
- Pluggable MegArray® ball grid array connector
- Optionally available with EMI shield
- Laser class 1M IEC 60825-1:2001 compliant
- Power supply 3.3 V
- Compatible with industry MSA

Applications

- High-speed interconnects within and between switches, routers and transport equipment
- Low cost SONET/SDH VSR (Very Short Reach) OC-192/STM64 connections
- InfiniBand® connections
- General high-bandwidth density interconnections

Description

The ZL60113 and ZL60114 together make a high speed transmitter/receiver pair for parallel fiber applications.

The ZL60113 transmitter module converts parallel electrical input signals via a laser driver and a VCSEL array into parallel optical output signals at a wavelength of 850 nm.

The ZL60114 receiver module converts parallel optical input signals via a PIN photodiode array and a transimpedance and limiting amplifier into electrical output signals.

The modules are pluggable each fitted with an industry-standard MegArray® BGA connector. This provides ease of assembly on the host board and enables provisioning of bandwidth on demand.

Reliability assurance is based on Telcordia GR-468-CORE and the parts are compliant to the EU directive 2002/95/EC issued 27 January 2003 [RoHS].



Exemption 6 & 7

Table of Contents

Features	1
Applications	1
Description	1
Absolute Maximum Ratings	3
Recommended Operating Conditions	3
ZL60113 Transmitter Specifications	4
Transmitter Control and Status Signals	6
Transmitter Control and Status Timing Diagrams	7
Transmitter Pinout Assignments	9
Transmitter Pin Description	10
ZL60114 Receiver Specifications	11
Receiver Control and Status Signals	12
Receiver Control and Status Timing Diagrams	13
Receiver Pinout Assignments	14
Receiver Pin Description	15
Handling instructions	15
Cleaning the Optical Interface	16
Connectors	16
ESD Handling	16
Link Reach	17
Link Model Parameters	17
Trademarks	17

Absolute Maximum Ratings

Not necessarily applied together. Exceeding these values may cause permanent damage. Functional operation under these conditions is not implied.

Parameter	Symbol	Min.	Max.	Unit
Supply voltage	V_{CC}	-0.5	3.6	V
Differential input voltage amplitude ¹	ΔV		2.4	V
Voltage on any pin	V_{PIN}	-0.3	$V_{CC} + 0.3$	V
Relative humidity (non-condensing)	M_{OS}	5	95	%
Storage temperature	T_{STG}	-40	100	°C
ESD resistance	V_{ESD}		±500	V

1. Differential input voltage amplitude are peak to peak values.

Recommended Operating Conditions

These parameters apply both to the transmitter and the receiver.

Parameter	Symbol	Min.	Max.	Unit
Power supply voltage	V_{CC}	3.135	3.465	V
Operating case temperature	T_{CASE}	0	80	°C
Signaling rate (per channel) ¹	f_D	1.0	3.125	Gbps
Link distance ²	LD	2		m
Data I/O DC blocking capacitors ³	C_{BLK}	100		nF
Power supply noise ⁴	V_{NPS}		200	mV _{p-p}

1. Data patterns are to have maximum run lengths and DC balance shifts no worse than that of a Pseudo Random Bit Sequence of length $2^{23}-1$ (PRBS-23). Information on lower bit rates is available on request.

2. For maximum distance, see Table 6.

3. For AC-coupling, DC blocking capacitors external to the module with a minimum value of 100 nF is recommended.

4. Power supply noise is defined at the supply side of the recommended filter for all V_{CC} supplies over the frequency range of 500 Hz to 3125 MHz with the recommended power supply filter in place.

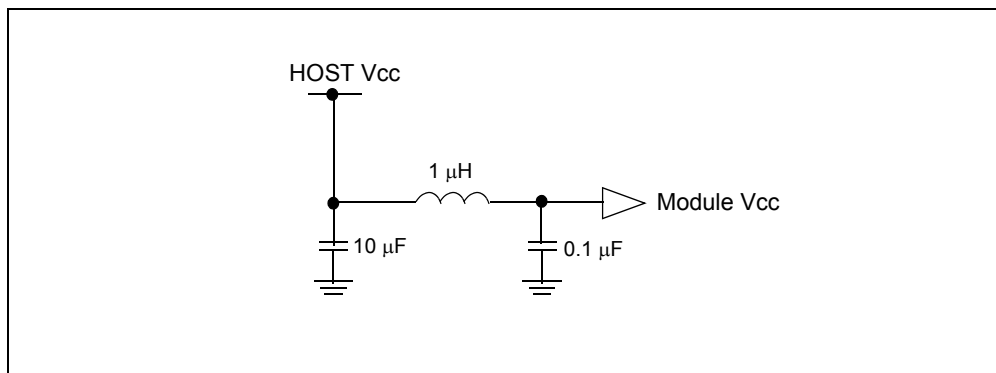

Figure 1 - Recommended Power Supply Filter

ZL60113 Transmitter Specifications

All parameters below require operating conditions according to “Recommended Operating Conditions” on page 3.

Parameter	Symbol	Min.	Max.	Unit
<i>Optical Parameters</i>				
Launch power (50/125 μm MMF) ¹	P_{OUT}		-2	dBm
Extinguished output power	P_{OFF}		-30	dBm
Extinction ratio	ER	6		dB
Optical modulation amplitude ²	OMA	0.190		mW
Center wavelength	λ_{C}	830	860	nm
Spectral width ³	$\Delta\lambda$		0.85	nm _{rms}
Relative intensity noise OMA	$\text{RIN}_{12\text{OMA}}$		-120	dB/Hz
Optical output rise time (20 - 80%)	t_{RO}		120	ps
Optical output fall time (20 - 80%)	t_{FO}		120	ps
Total jitter contributed (peak to peak) ⁴	TJ		0.32	UI
Deterministic jitter contributed (peak to peak) ⁵	DJ		0.14	UI
Channel to channel skew ⁶	t_{SK}		100	ps
<i>Electrical Parameters</i>				
Power dissipation	P_{D}		1.5	W
Supply current	I_{CC}		450	mA
Differential input voltage amplitude (peak to peak) ⁷	ΔV_{IN}	200	1800	mV _{p-p}
Differential input impedance ⁸	Z_{IN}	80	120	Ω
Electrical input rise time (20 - 80%)	t_{RE}		150	ps
Electrical input fall time (20 - 80%)	t_{FE}		150	ps

1. The output optical power is compliant with IEC 60825-1 Amendment 2, Class 1M Accessible Emission Limits.

2. OMA are peak to peak values.

3. Spectral width is measured as defined in EIA/TIA-455-127 *Spectral Characterization of Multimode Laser Diodes*.

4. Total jitter is TP2 - TP1 as defined in IEEE 802.3 clause 38.6 (Gigabit Ethernet).

5. Deterministic jitter is informative. The random jitter and deterministic jitter together should be no higher than total jitter.

6. Channel skew is defined for the condition of equal amplitude, zero ps skew signals applied to the transmitter inputs.

7. Differential input voltage is defined as the peak to peak value of the differential voltage between DIN+ and DIN-. Data inputs are CML compatible.

8. Differential input impedance is measured between DIN+ and DIN-.

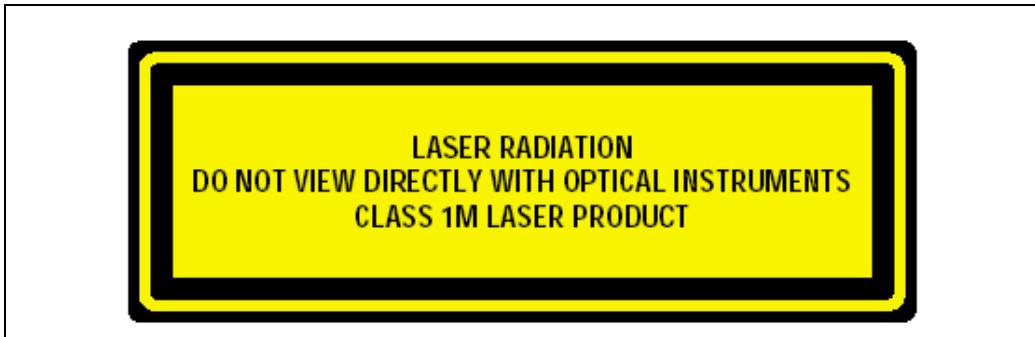

Classified in accordance with IEC 60825-1/A2:2001, IEC 60825-2: 2000

Class 1 M Laser Product

Emitted wavelength: 840 nm

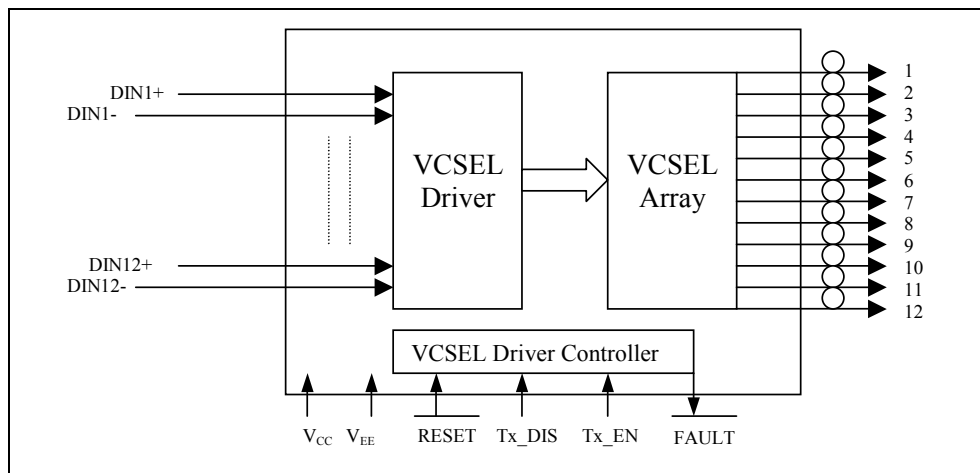

Figure 2 - ZL60113 Transmitter Block Diagram

Front view - MTP key up											
Ch12	Ch11	Ch10	Ch9	Ch8	Ch7	Ch6	Ch5	Ch4	Ch3	Ch2	Ch1
Host circuit board											

Table 1 - Transmitter Optical Channel Assignment

Transmitter Control and Status Signals

The following table shows the timing relationships of the status and control signals of the pluggable optical transmitter.

Parameter	Symbol	Min.	Typ.	Max.	Unit
Control input voltage high ¹	V_{IH}	$0.6V_{CC}$			V
Control input voltage low	V_{IL}			$0.2V_{CC}$	V
Control pull-up resistor ²	R_{PU}		10		$k\Omega$
Control pull-down resistor ³	R_{PD1}		10		$k\Omega$
Status output voltage low ^{4, 5}	V_{OL}			0.4	V
Status pull-down resistor ⁴	R_{PD2}		10		$k\Omega$
\overline{FAULT} assert time	T_{FA}			100	μs
\overline{FAULT} lasers off	T_{FD}			100	μs
\overline{RESET} duration	T_{TDD}	10			μs
\overline{RESET} assert time	T_{OFF}		5	10	μs
\overline{RESET} de-assert time	T_{ON}			100	ms
Tx_EN assert time	T_{TEN}			1	ms
Tx_EN de-assert time	T_{TD}		5	10	μs
Tx_DIS assert time	T_{TD}		5	10	μs
Tx_DIS de-assert time	T_{TEN}			1	ms

1. Applies to control signals \overline{RESET} , Tx_DIS and Tx_EN.
2. Applies to control signals \overline{RESET} and Tx_EN. Internal pull-up resistor.
3. Applies to control signal Tx_DIS. Internal pull-down resistor.
4. Applies to status signal \overline{FAULT} . Internal pull-down to V_{EE} .
5. With status output sink current max. 2 mA.

Transmitter Control and Status Timing Diagrams

The following figures show the timing relationships of the status and control signals of the pluggable optical transmitter.

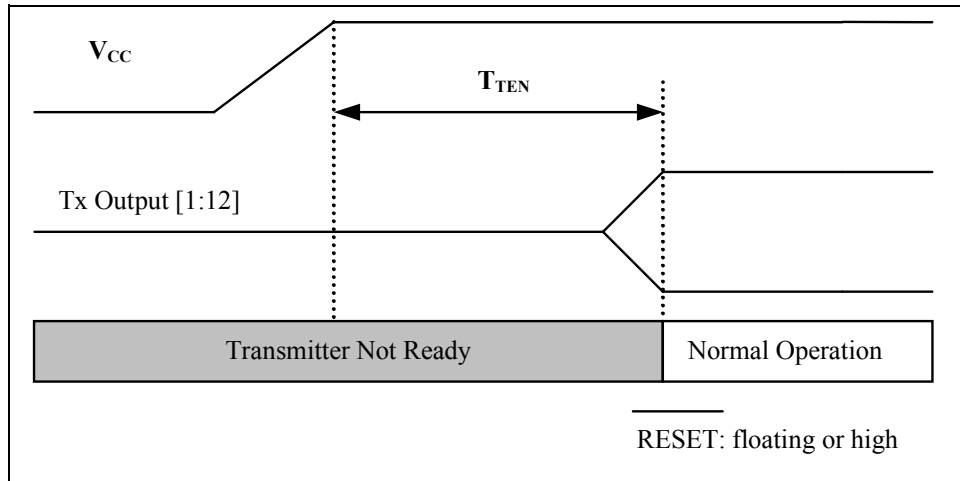

Figure 3 - Transmitter Power-up Sequence

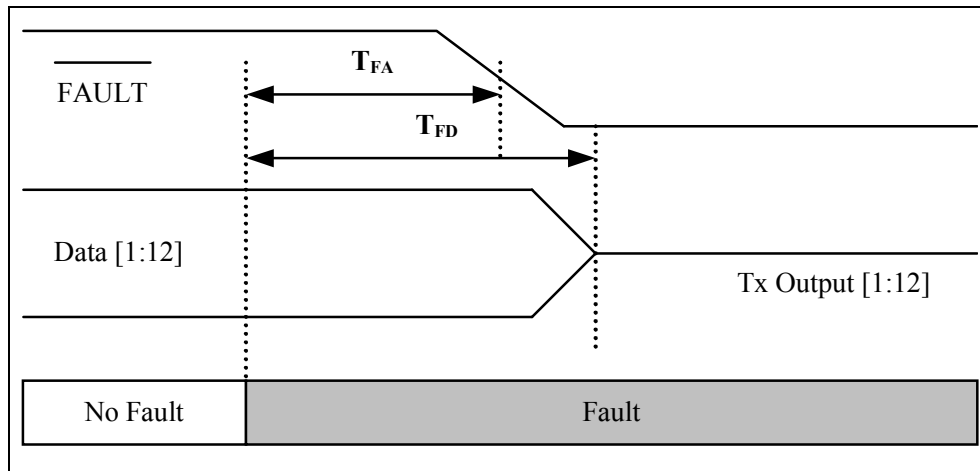

Figure 4 - Transmitter Fault Signal Timing Diagram

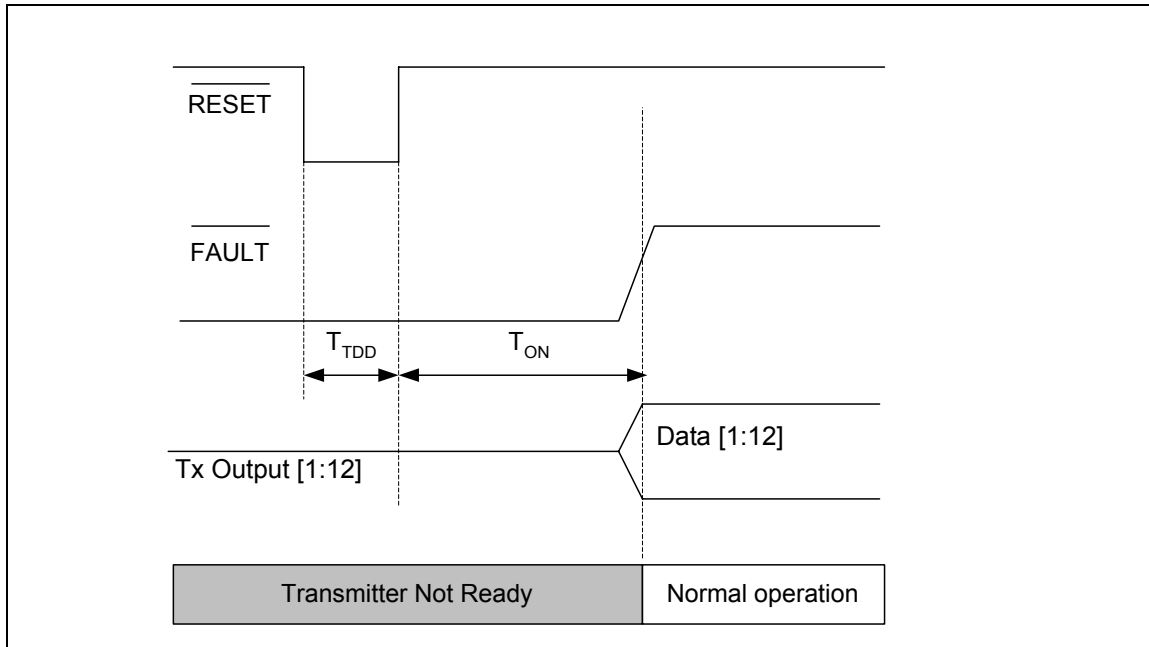

Figure 5 - Transmitter Reset Signal Timing Diagram

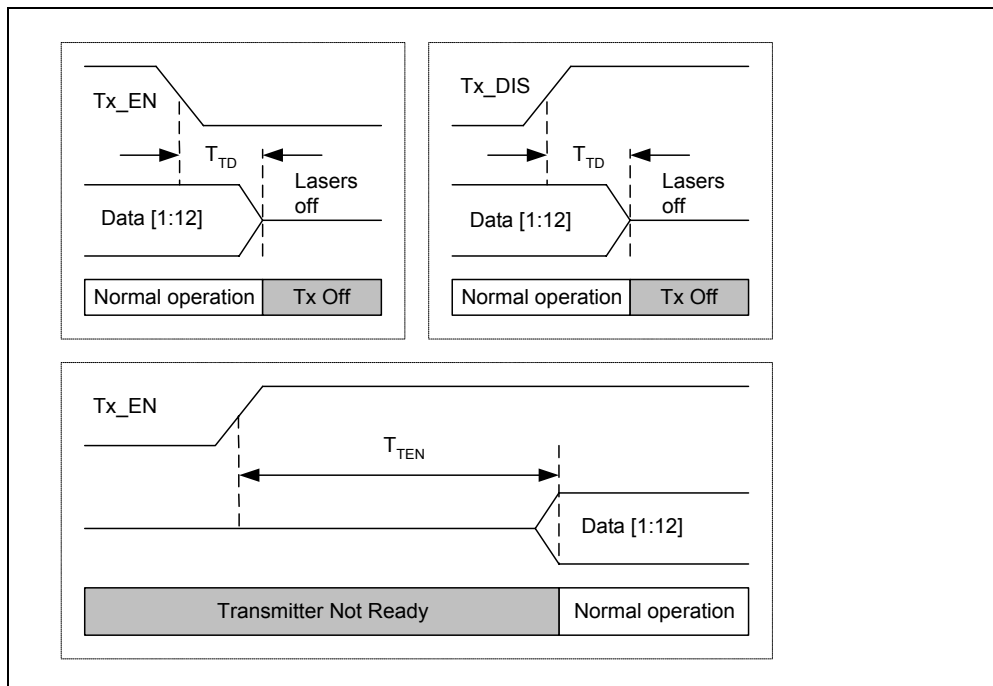

Figure 6 - Transmitter Enable and Disable Timing Diagram

	Tx_DIS High	Tx_DIS Low
Tx_EN High	Transmitter disabled	Normal operation
Tx_EN Low	Transmitter disabled	Transmitter disabled

Table 2 - Truth Table for Transmitter Operation (Pre-condition: RESET floating or HIGH)

Transmitter Pinout Assignments

	K	J	H	G	F	E	D	C	B	A
1	NIC	NIC	NIC	V _{EE}	V _{EE}	V _{EE}	V _{EE}	V _{EE}	V _{EE}	NIC
2	NIC	NIC	NIC	V _{EE}	V _{EE}	DIN6+	V _{EE}	V _{EE}	DIN9+	V _{EE}
3	NIC	V _{CC}	V _{CC}	V _{EE}	DIN5+	DIN6-	V _{EE}	DIN8+	DIN9-	V _{EE}
4	NIC	V _{CC}	V _{CC}	DIN4+	DIN5-	V _{EE}	DIN7+	DIN8-	V _{EE}	NIC
5	NIC	V _{CC}	V _{CC}	DIN4-	V _{EE}	DIN3+	DIN7-	V _{EE}	DIN10-	V _{EE}
6	NIC	V _{CC}	V _{CC}	V _{EE}	DIN2+	DIN3-	V _{EE}	DIN11-	DIN10+	V _{EE}
7	NIC	NIC	NIC	DIN1+	DIN2-	V _{EE}	DIN12-	DIN11+	V _{EE}	NIC
8	NIC	RESET	FAULT	DIN1-	V _{EE}	V _{EE}	DIN12+	V _{EE}	V _{EE}	NIC
9	NIC	Tx_EN	Tx_DIS	V _{EE}	V _{EE}	V _{EE}	V _{EE}	V _{EE}	V _{EE}	NIC
10	NIC	NIC	NIC	NIC	NIC	NIC	DNC	DNC	DNC	DNC

**Table 3 - Transmitter Host Circuit Board Layout (Top view, toward MPO/MTP™ connector end)
(10x10 array, 1.27 mm pitch)**

Transmitter Pin Description

Signal Name	Type	Description	Comments
DIN[1:12] +/-	Data input	Transmitter data in, channel 1 to 12	Internal differential termination at 100 Ω .
V _{CC}		Transmitter power supply rail	
V _{EE}		Transmitter signal common. All transmitter voltages are referenced to this potential unless otherwise stated.	Directly connect these pads to the PC board transmitter signal ground plane.
Tx_EN	Control input	Transmitter enable. HIGH: normal operation LOW: disable transmitter	Active high, internal pull-up. See Table 2.
Tx_DIS	Control input	Transmitter disable. HIGH: disable transmitter LOW: normal operation	Active high, internal pull-down. See Table 2.
$\overline{\text{FAULT}}$	Status output	Transmitter fault. HIGH: normal operation LOW: laser fault detected on at least one channel	When active, all channels are disabled. Clear by reset signal. Internal pull-up.
$\overline{\text{RESET}}$	Control input	Transmitter reset. HIGH: normal operation LOW: reset to clear fault signal	Internal pull-up.
DNC		Do not connect to any potential, including ground.	
NIC		No internal connection.	

ZL60114 Receiver Specifications

All parameters below require operating conditions according to “Recommended Operating Conditions,” on page 3 and a termination load of 100 Ω differential at the electrical output.

Parameter	Symbol	Min.	Max.	Unit
<i>Optical Parameters</i>				
Receiver sensitivity (OMA) (50/125 μm MMF) ¹	S_{OMA}	38	755	μW
Center wavelength	λ_{C}	830	860	nm
Return loss ²	RL	12		dB
Stressed receiver sensitivity (OMA) ³	SS_{OMA}	80		μW
Total link jitter contribution (peak to peak) ⁴	TJ_{L}		0.65	UI
Deterministic link jitter contribution (peak to peak) ⁵	DJ_{L}		0.27	UI
Channel to channel skew ⁶	t_{SK}		100	ps
Signal detect assert	P_{SA}		-15	dBm
Signal detect de-assert	P_{SD}	-30		dBm
<i>Electrical Parameters</i>				
Power dissipation	P_{D}		1.5	W
Supply current	I_{CC}		450	mA
Differential output voltage amplitude (peak to peak) ⁷	ΔV_{OUT}	500	800	$\text{mV}_{\text{p-p}}$
Output differential load impedance	Z_{L}	80	120	Ω
Electrical output rise time (20 - 80%)	t_{RE}		120	ps
Electrical output fall time (20 - 80%)	t_{FE}		120	ps

1. Optical modulation amplitude are peak to peak values. Receiver sensitivity is measured using a source that does not degrade the sensitivity measurement, i.e. ideal source with fast rise/fall time and low RIN. Receive power for a channel is measured for a BER of 10^{-12} and 6 dB extinction ratio and the other 11 channels operating with incident power of 6 dB above the channel under test.

2. Return loss is measured as defined in TIA/EIA-455-107A *Determination of Component Reflectance or Link/System Return Loss Using a Loss Test Set*.

3. Based on Gigabit Ethernet Link model. See “Link Model Parameters,” on page 17 and receiver sensitivity specified.

4. Total link jitter equals TP4 - TP1.

5. Deterministic jitter is informative. Deterministic link jitter equals TP4 - TP1.

6. Channel skew is defined for the condition of equal amplitude, zero ps skew signals applied to the receiver inputs.

7. Differential output voltage is defined as the peak to peak value of the differential voltage between DOUT+ and DOUT- and measured with a 100 Ω differential load connected between DOUT+ and DOUT-. Data outputs are CML compatible.

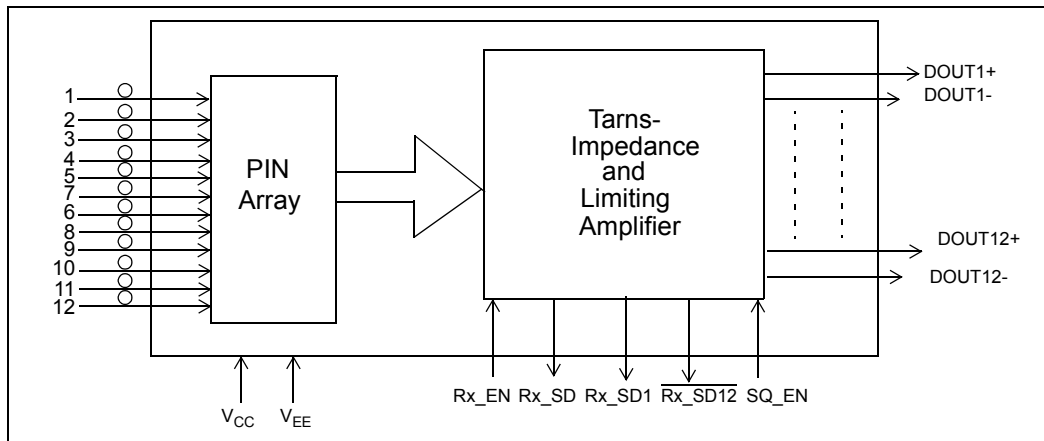

Figure 7 - ZL60114 Receiver Block Diagram

Front view - MTP key up											
Ch12	Ch11	Ch10	Ch9	Ch8	Ch7	Ch6	Ch5	Ch4	Ch3	Ch2	Ch1
Host circuit board											

Table 4 - Receiver Optical Channel Assignment

Receiver Control and Status Signals

The following table shows the timing relationships of the status and control signals of the pluggable optical receiver.

Parameter	Symbol	Min.	Typ.	Max.	Unit
Control input voltage high ¹	V_{IH}	$0.6V_{CC}$			V
Control input voltage low ¹	V_{IL}			$0.2V_{CC}$	V
Control input pull-up current ¹	$ I_{IN} $	10		100	μA
Status output voltage low ^{2, 3}	V_{OL}			0.4	V
Status output pull-up resistor ²	R_{PU}		3.25		$k\Omega$
Receiver signal detect assert time	T_{SD}		50	200	μs
Receiver signal detect de-assert time	T_{LOS}		50	200	μs
Receiver enable assert time	T_{RXEN}		33		ms
Receiver enable de-assert time	T_{RXD}		5		μs

1. Applies to control signals Rx_EN, SQ_EN.
2. Applies to status signal Rx_SD. Internal pull-up to V_{CC} .
3. With status output sink current max 2 mA.

Receiver Control and Status Timing Diagrams

The following figures show the timing relationships of the status and control signals of the pluggable optical receiver.

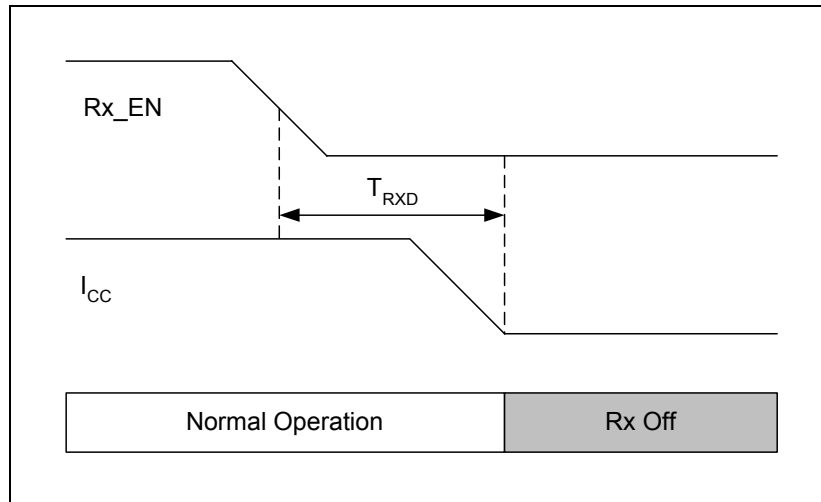
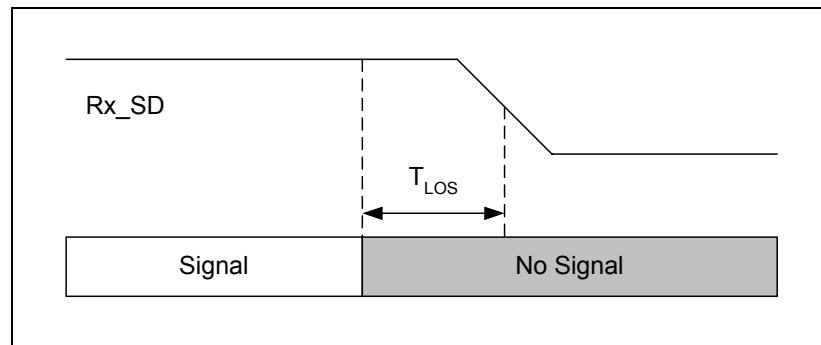
**Figure 8 - Receiver Enable Signal Timing Diagram****Figure 9 - Receiver Signal Detect Timing Diagram**

Receiver Pinout Assignments

	K	J	H	G	F	E	D	C	B	A
1	DNC	NIC	NIC	V _{EE}	V _{EE}	V _{EE}	V _{EE}	V _{EE}	V _{EE}	NIC
2	DNC	NIC	NIC	V _{EE}	V _{EE}	DOUT6-	V _{EE}	V _{EE}	DOUT9-	V _{EE}
3	NIC	V _{CC}	V _{CC}	V _{EE}	DOUT5-	DOUT6+	V _{EE}	DOUT8-	DOUT9+	V _{EE}
4	NIC	V _{CC}	V _{CC}	DOUT4-	DOUT5+	V _{EE}	DOUT7-	DOUT8+	V _{EE}	NIC
5	NIC	V _{CC}	V _{CC}	DOUT4+	V _{EE}	DOUT3-	DOUT7+	V _{EE}	DOUT10+	V _{EE}
6	NIC	V _{CC}	V _{CC}	V _{EE}	DOUT2-	DOUT3+	V _{EE}	DOUT11+	DOUT10-	V _{EE}
7	NIC	NIC	Rx_SD	DOUT1-	DOUT2+	V _{EE}	DOUT12+	DOUT11-	V _{EE}	NIC
8	DNC	$\overline{\text{RX_SD12}}$	Rx_SD1	DOUT1+	V _{EE}	V _{EE}	DOUT12-	V _{EE}	V _{EE}	NIC
9	DNC	Rx_EN	NIC	V _{EE}	V _{EE}	V _{EE}	V _{EE}	V _{EE}	V _{EE}	NIC
10	SQ_EN	NIC	NIC	NIC	NIC	NIC	DNC	DNC	DNC	DNC

**Table 5 - Receiver Pinout Assignments (Top view, toward MPO/MTP™ connector end)
(10x10 array, 1.27 mm pitch)**

Receiver Pin Description

Signal Name	Type	Description	Comments
DOUT[1:12] +/-	Data output	Receiver data out, channel 1 to 12.	
V _{CC}		Receiver power supply rail.	
V _{EE}		Receiver signal common. All receiver voltages are referenced to this potential unless otherwise stated.	Directly connect these pads to the PC board receiver signal ground plane.
Rx_EN	Control input	Receiver enable. HIGH: normal operation LOW: disable receiver	Internal pull-up.
Rx_SD	Status output	Receiver signal detect. HIGH: valid optical input on all channels LOW: loss of signal on at least one channel	
Rx_SD1	Status output	Receiver signal detect channel 1. HIGH: valid optical input on channel 1 LOW: loss of signal on channel 1	
$\overline{\text{RX_SD12}}$	Status output	Receiver signal detect channel 12. HIGH: loss of signal on channel 12 LOW: valid optical input on channel 12	
SQ_EN	Control input	Squelch enable. HIGH: squelch function enabled. Data OUT is squelched on any channels that have loss of signal LOW: squelch function disabled	Internal pull-up.
DNC		Do not connect to any potential, including ground.	
NIC		No internal connection.	

Handling Instructions

Cleaning the Optical Interface

A protective connector plug is supplied with each module. This plug should remain in place whenever a fiber cable is not inserted. This will keep the optical port free from dust or other contaminants, which may potentially degrade the optical signal. Before reattaching the connector plug to the module, visually inspect the plug and remove any contamination. If the module's optical port becomes contaminated, it can be cleaned with high-pressure nitrogen (the use of fluids, or physical contact, is not advised due to potential for damage).

Before a fiber cable connector is attached to the module, it is recommended to clean the fiber cable connector using an optical connector cleaner, or according to the cable manufacturer's instructions. It is also recommended to clean the optical port of the module with high-pressure nitrogen.

Connectors

For optimum performance, it is recommended that the number of insertions is limited to 50 for the electrical MegArray connector and 200 for the optical MPO/MTP connector.

ESD Handling

When handling the modules, precautions for ESD sensitive devices should be taken. These include use of ESD protected work areas with wrist straps, controlled work-benches, floors etc.

Link Reach

The following table lists the minimum reach distance of the 12 channel pluggable optical modules for different multi-mode fiber (MMF) types and bandwidths assuming worst case parameters. Each case allows for a maximum of 2 dB per channel connection loss for patch cables and other connectors.

Fiber Type [core / cladding μm]	Modal Bandwidth @ 850 nm [MHz*km]	Reach Distance @ 1 Gbps [m]	Reach Distance @ 2.5 Gbps [m]	Reach Distance @ 3.125 Gbps [m]
50/125 MMF	400	650	260	170
50/125 MMF	500	750	300	200

Table 6 - Link Reach for Different Fiber Types and Data Rates

Significantly longer operating distance than the range specified here can be achieved using transmitters, receivers and / or cables meeting specification but performing better than worst case.

Link Model Parameters

The link reaches above have been calculated using the following link model parameters and Gigabit Ethernet link model version 2.3.5 (filename: 5pmd047.xls).

Parameter	Symbol	Value	Unit
Mode partition noise k-factor	k	0.3	
Modal noise	MN	0.3	dB
Dispersion slope parameter	S_O	0.11	ps/nm ² *km
Wavelength of zero dispersion	U_O	1320	nm
Attenuation coefficient at 850 nm	α_{dB}	3.5	dB/km
Conversion factor	C1	480	ns.MHz
Q-factor [BER 10 ⁻¹²]	Q	7.04	
TP4 eye opening		0.3	UI
DCD allocation at TP3	DCD DJ	0.08	UI
RMS baseline wander S.D.	σ_{BLW}	0.025	
RIN coefficient	k_{RIN}	0.70	
Conversion factor	c_{rx}	329	ns.MHz

Trademarks

Infiniband is a registered trademark of the InfiniBand Trade Association.

MTP is a registered trademark of US Conec Ltd.

The MegArray is a registered trademark of FCI.



**For more information about all Zarlink products
visit our Web Site at
www.zarlink.com**

Information relating to products and services furnished herein by Zarlink Semiconductor Inc. or its subsidiaries (collectively "Zarlink") is believed to be reliable. However, Zarlink assumes no liability for errors that may appear in this publication, or for liability otherwise arising from the application or use of any such information, product or service or for any infringement of patents or other intellectual property rights owned by third parties which may result from such application or use. Neither the supply of such information or purchase of product or service conveys any license, either express or implied, under patents or other intellectual property rights owned by Zarlink or licensed from third parties by Zarlink, whatsoever. Purchasers of products are also hereby notified that the use of product in certain ways or in combination with Zarlink, or non-Zarlink furnished goods or services may infringe patents or other intellectual property rights owned by Zarlink.

This publication is issued to provide information only and (unless agreed by Zarlink in writing) may not be used, applied or reproduced for any purpose nor form part of any order or contract nor to be regarded as a representation relating to the products or services concerned. The products, their specifications, services and other information appearing in this publication are subject to change by Zarlink without notice. No warranty or guarantee express or implied is made regarding the capability, performance or suitability of any product or service. Information concerning possible methods of use is provided as a guide only and does not constitute any guarantee that such methods of use will be satisfactory in a specific piece of equipment. It is the user's responsibility to fully determine the performance and suitability of any equipment using such information and to ensure that any publication or data used is up to date and has not been superseded. Manufacturing does not necessarily include testing of all functions or parameters. These products are not suitable for use in any medical products whose failure to perform may result in significant injury or death to the user. All products and materials are sold and services provided subject to Zarlink's conditions of sale which are available on request.

Purchase of Zarlink's I²C components conveys a licence under the Philips I²C Patent rights to use these components in and I²C System, provided that the system conforms to the I²C Standard Specification as defined by Philips.

Zarlink, ZL and the Zarlink Semiconductor logo are trademarks of Zarlink Semiconductor Inc.

Copyright Zarlink Semiconductor Inc. All Rights Reserved.

TECHNICAL DOCUMENTATION - NOT FOR RESALE
