

ZR431L

ADJUSTABLE PRECISION SHUNT REGULATOR

SUMMARY

DESCRIPTION

The ZR431L is a three terminal adjustable shunt regulator offering excellent temperature stability and output current handling capability up to 25mA. The output voltage may be set to any chosen voltage between 1.24 and 10 volts by selection of two external divider resistors.

The devices can be used as a replacement for zener diodes in many applications requiring an improvement in zener performance.

The ZR431L is particularly used in the feedback control loop of switch mode power supplies. In this application the device 1.24 volt reference enables the generation of low voltage supplies, typically 3.3. volts or 3 volts.

FEATURES

- 2.5% and 1% tolerance
- Max. temperature coefficient 50 ppm/°C
- Temperature compensated for operation over the full temperature range
- 100 μ A to 25mA current sink capability
- Surface mount SOT23 package
- TO92 package

APPLICATIONS

- Switch mode power supplies
- Shunt regulator
- Series regulator
- Voltage monitor
- Over voltage / under voltage protection

ORDERING INFORMATION

DEVICE	PACK	TOL %	REEL SIZE	QUANTITY PER REEL	PART MARK
ZR431LF01TA	SOT23	1	7"	3000	43M
ZR431LF02TA	SOT23	2.5	7"	3000	43L
ZR431LC01STOB	TO92	1		1500	ZR431L01
ZR431LC02STOB	TO92	2.5		1500	ZR431L02
ZR431LC01L	TO92	1	LOOSE		ZR431L01
ZR431LC02L	TO92	2.5	LOOSE		ZR431L02

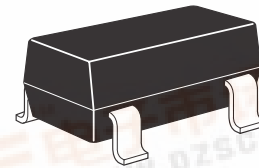

SOT23



TO92

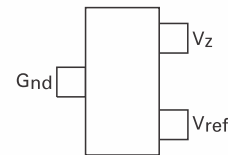

SOT23

Top View



TO92

Underside View

ZR431L

ABSOLUTE MAXIMUM RATINGS

PARAMETER	SYMBOL	LIMIT	UNIT
Cathode Voltage	V_Z	10	V
Cathode Current		50	mA
Operating Temperature	T_{OMP}	-40 to 85	°C
Storage Temperature	T_{STG}	-55 to 125	°C

RECOMMENDED OPERATING CONDITIONS

PARAMETER	MIN.	MAX.
Cathode Voltage	V_{REF}	10V
Cathode Current	100 μ A	25mA

POWER DISSIPATION (at $T_{amb} = 25^\circ\text{C}$ unless otherwise stated)

PACKAGE	VALUE	UNIT
SOT23	330	mW
TO92	600	mW

ZR431L

BLOCK DIAGRAM

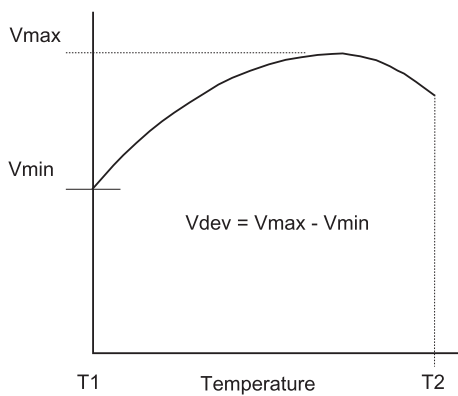
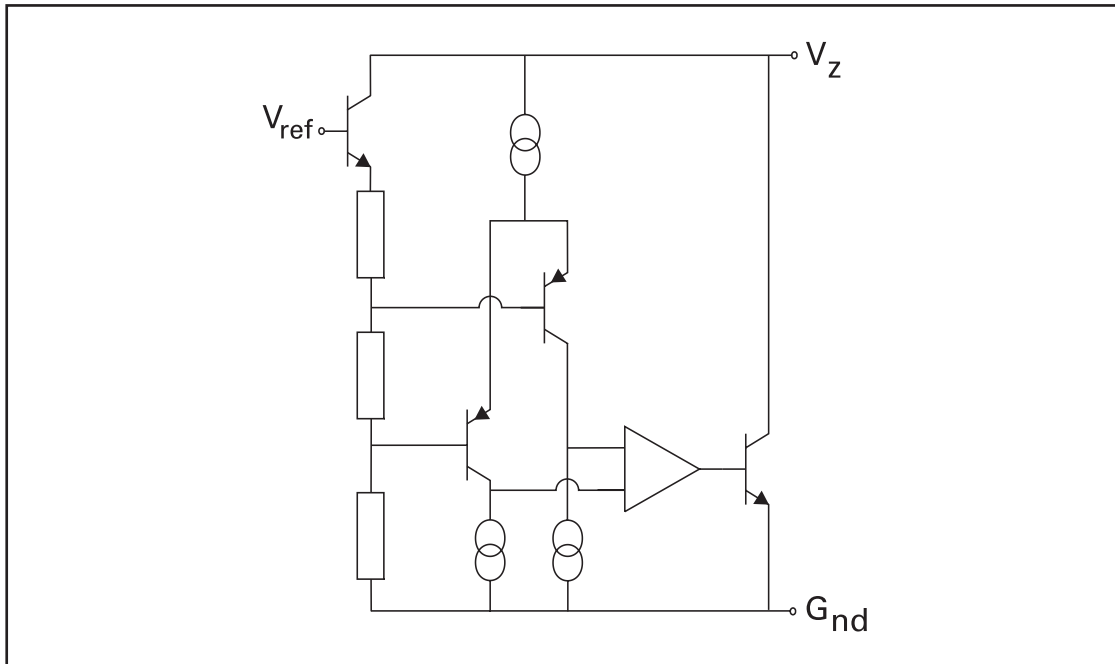

Deviation of reference input voltage, V_{dev} , is defined as the maximum variation of the reference input voltage over the full temperature range.

The average temperature coefficient of the reference input voltage, V_{ref} is defined as:

$$V_{ref}(\text{ppm} / C) = \frac{V_{dev} \times 1000000}{V_{ref}(T1 - T2)}$$

The dynamic output impedance, R_z , is defined as:

$$R_z = \frac{\Delta V_z}{\Delta I_z}$$

When the device is programmed with two external resistors, $R1$ and $R2$, (fig 2), the dynamic output impedance of the overall circuit, R' , is defined as:

$$R' = R_z \left(1 + \frac{R1}{R2}\right)$$

ZR431L

ELECTRICAL CHARACTERISTICS (at $T_{amb} = 25^{\circ}\text{C}$ unless otherwise stated)

PARAMETER	SYMBOL	MIN.	TYP.	MAX.	UNIT	CONDITIONS
Reference Voltage	V_{ref}	1.209	1.24	1.271	V	$I_L = 10\text{mA}$ (Fig1), $V_Z = V_{ref}$
	V_{ref}	1.228	1.24	1.252	V	
Deviation of Reference Input Voltage over Temperature	V_{dev}		4.0	8.0	mV	$I_L = 10\text{mA}$, $V_Z = V_{ref}$ $T_a = \text{full range}$ (Fig 1)
Ratio of the change in Reference Voltage to the change in Cathode Voltage	$\frac{\Delta V_{ref}}{\Delta V_Z}$		0.5	2.0	mV/V	V_Z from V_{ref} to 10V $I_Z = 10\text{mA}$ (Fig2)
Reference Input Current	I_{ref}	0.02	0.11	0.4	μA	$R1 = 10\text{k}$, $R2 = \text{O/C}$, $I_L = 10\text{mA}$ (fig2)
Deviation of Reference Input Current over Temperature	ΔI_{ref}		0.02	0.2	μA	$R1 = 10\text{k}$, $R2 = \text{O/C}$, $I_L = 10\text{mA}$ $T_a = \text{full range}$ (Fig2)
Minimum Cathode Current for Regulation	I_{Zmin}		30	100	μA	
Off-state Current	I_{Zoff}		10	30	μA	$V_Z = 10\text{V}$, $V_{ref} = 0\text{V}$ (Fig3)
Dynamic Output Impedance	R_Z		0.25	2	Ω	$V_Z = V_{ref}$ (Fig1), $f = 0\text{Hz}$, $I_L = 10\text{mA}$

DC TEST CIRCUITS

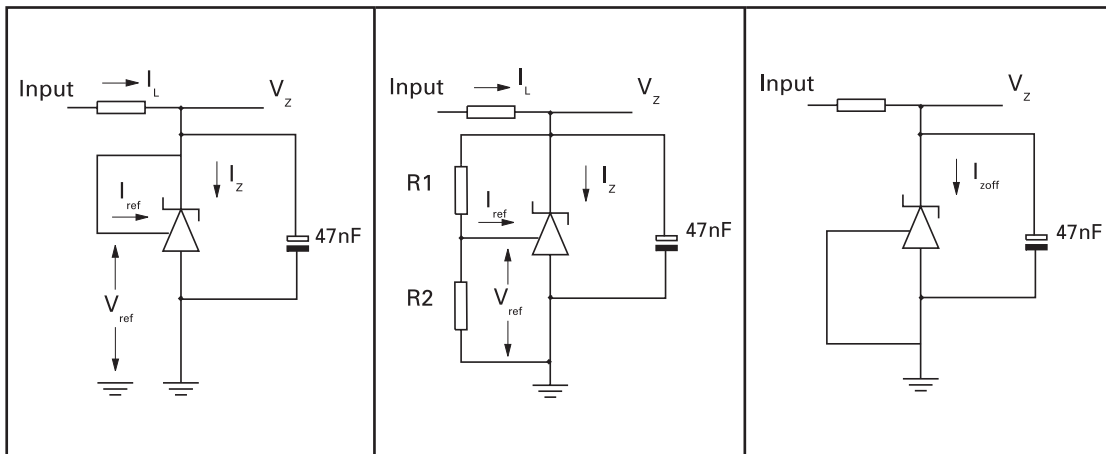

Fig 1 - Test Circuit for $V_Z = V_{ref}$

Fig 2 - Test Circuit for $V_Z > V_{ref}$

Fig 3 - Test Circuit for Off State current

ZR431L

TYPICAL CHARACTERISTICS

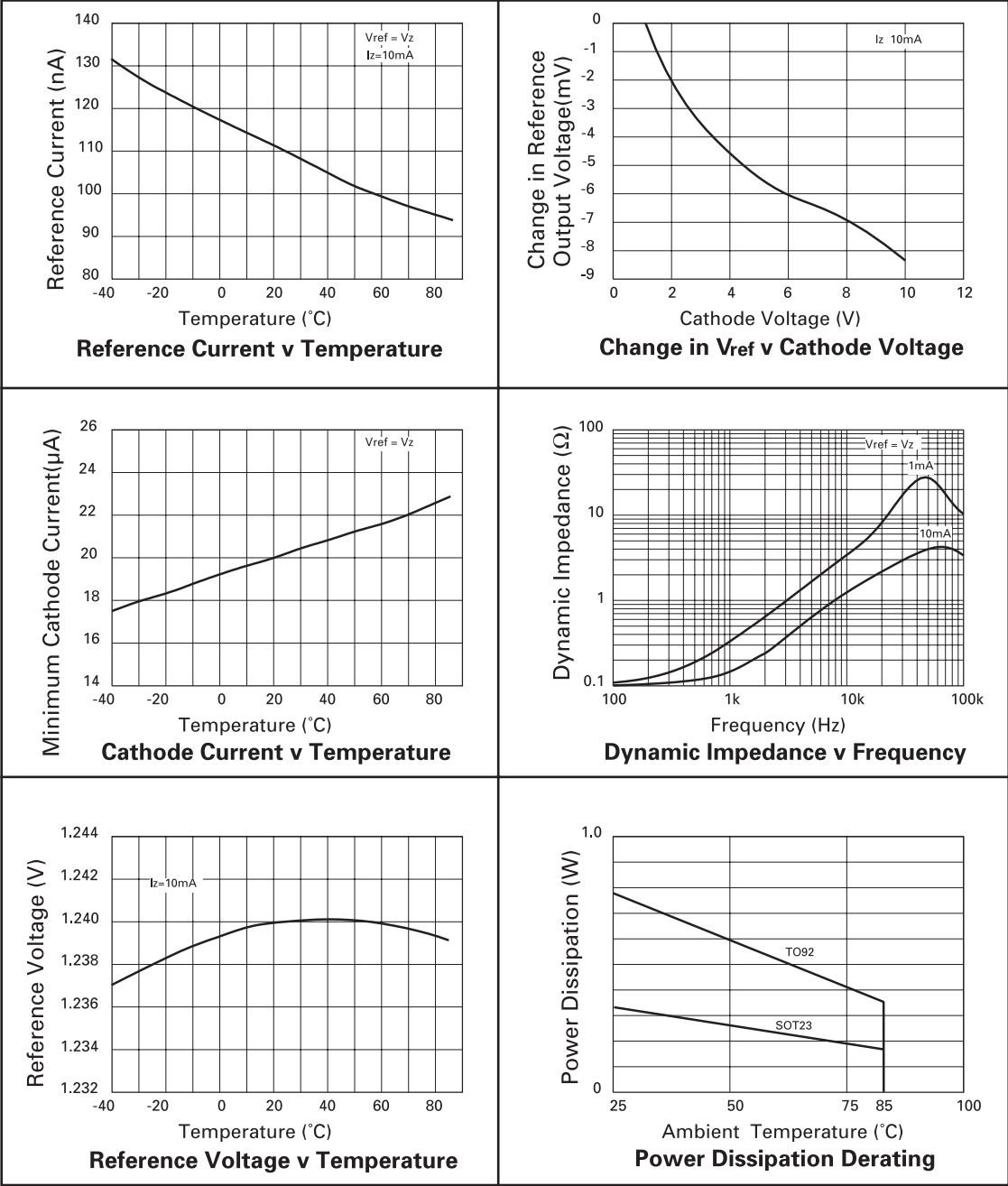

ZR431L

APPLICATIONS CIRCUITS

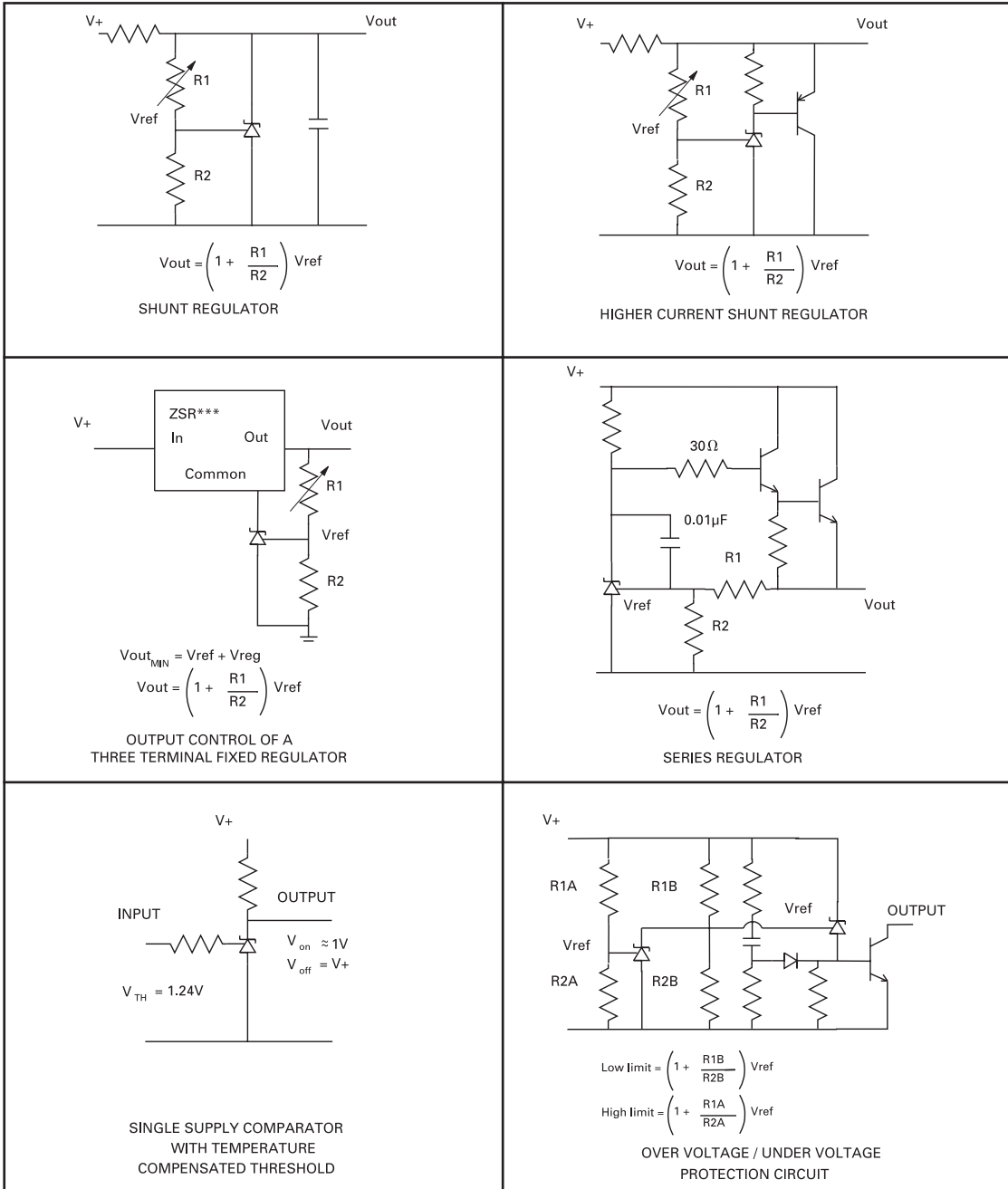

ZR431L

TYPICAL CHARACTERISTICS

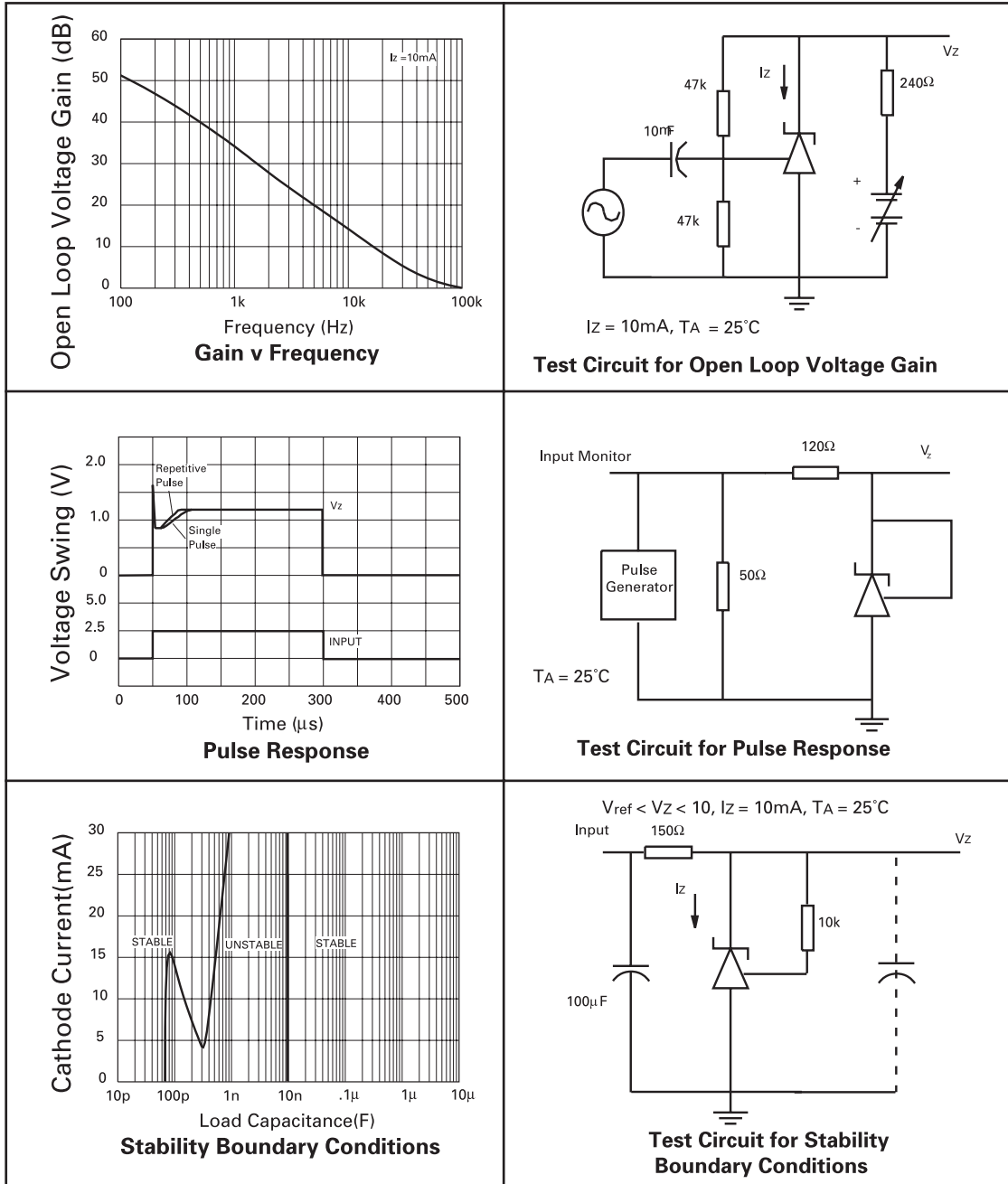

ZR431L

SOT23 PACKAGE OUTLINE AND PAD LAYOUT DETAILS

PACKAGE OUTLINE

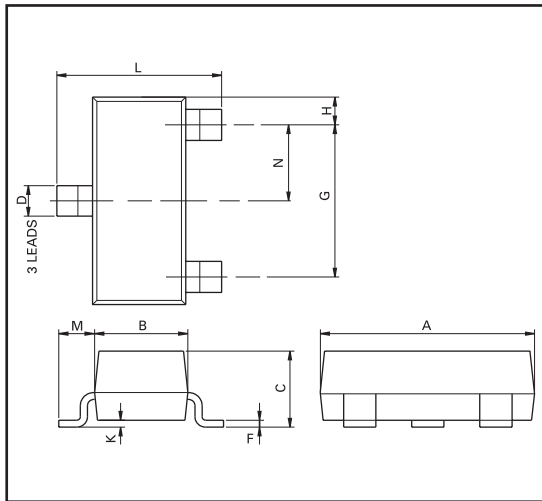

PAD LAYOUT

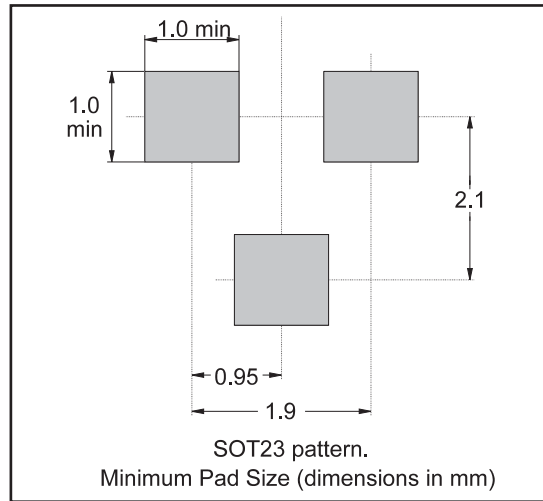

Controlling dimensions are in millimetres. Approximate conversions are given in inches

PACKAGE DIMENSIONS

DIM	Millimetres		Inches		DIM	Millimetres		Inches	
	Min	Max	Min	Max		Min	Max	Min	Max
A	2.67	3.05	0.105	0.120	G	NOM 1.9		NOM 0.037	
B	1.20	1.40	0.047	0.055	K	0.01	0.10	0.0004	0.004
C	-	1.10	-	0.043	L	2.10	2.50	0.083	0.0985
D	0.37	0.53	0.0145	0.021	N	NOM 0.95		NOM 0.037	
F	0.085	0.15	0.0033	0.0059					

ZR431L

TO92 PACKAGE OUTLINE DETAILS

PACKAGE OUTLINE

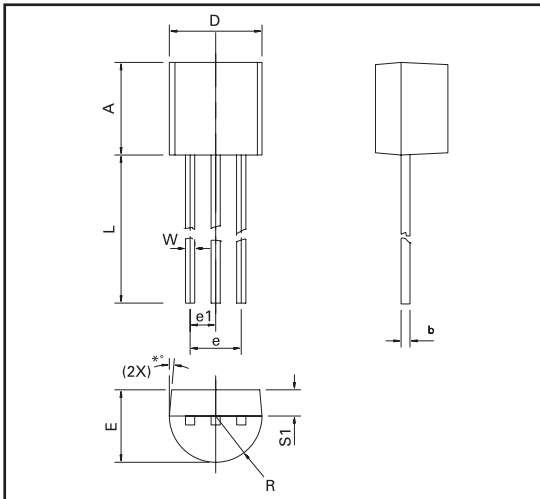

Controlling dimensions are in millimetres. Approximate conversions are given in inches

PACKAGE DIMENSIONS

DIM	Millimetres		Inches		DIM	Millimetres		Inches	
	Min	Max	Min	Max		Min	Max	Min	Max
A	4.32	4.95	0.170	0.195	R	2.16	2.41	0.085	0.095
b	0.36	0.51	0.014	0.020	S1	1.14	1.52	0.045	0.060
E	3.30	3.94	0.130	0.155	W	0.41	0.56	0.016	0.022
e	2.41	2.67	0.095	0.105	D	4.45	4.95	0.175	0.195
e1	1.14	1.40	0.045	0.055	*°	4°	6°	4°	6°
L	12.70	15.49	0.500	0.610					

© Zetex plc 2003

Europe		Americas	Asia Pacific
Zetex plc Fields New Road Chadderton Oldham, OL9 8NP United Kingdom Telephone: (44) 161 622 4444 Fax: (44) 161 622 4446 hq@zetex.com	Zetex GmbH Streitfeldstraße 19 D-81673 München Germany Telefon: (49) 89 45 49 49 0 Fax: (49) 89 45 49 49 49 europe.sales@zetex.com	Zetex Inc 700 Veterans Memorial Hwy Hauppauge, NY 11788 USA Telephone: (1) 631 360 2222 Fax: (1) 631 360 8222 usa.sales@zetex.com	Zetex (Asia) Ltd 3701-04 Metroplaza Tower 1 Hing Fong Road Kwai Fong Hong Kong Telephone: (852) 26100 611 Fax: (852) 24250 494 asia.sales@zetex.com

These offices are supported by agents and distributors in major countries world-wide.

This publication is issued to provide outline information only which (unless agreed by the Company in writing) may not be used, applied or reproduced for any purpose or form part of any order or contract or be regarded as a representation relating to the products or services concerned. The Company reserves the right to alter without notice the specification, design, price or conditions of supply of any product or service.

For the latest product information, log on to www.zetex.com

ISSUE 2 - AUGUST 2003