



ZTLV431

1.24V Cost effective shunt regulator

Description

The ZTLV431 is a three terminal adjustable shunt regulator offering excellent temperature stability and output current handling capability up to 20mA. The output voltage may be set to any chosen voltage between 1.24 volts and 10 volts by selection of two external divider resistors.

The ZTLV431 can be used as a replacement for zener diodes in many applications requiring an improvement in zener performance.

The ZTLV431 is available as standard as an A grade which has an initial tolerance of 1%; a B grade is planned with an initial tolerance of 0.5%, and all cover the -40°C to 125°C temperature range as standard.

Features

- Low voltage operation $V_{REF} = 1.24V$
- Temperature range -40 to 125°C
- Reference voltage tolerance at 25°C
 - 0.5% ZTLV431B
 - 1% ZTLV431A
- Typical temperature drift
 - 4 mV (0°C to 70°C)
 - 6 mV (-40°C to 85°C)
 - 11mV (-40°C to 125°C)
- 100µA minimum cathode current
- 0.25Ω typical output impedance
- Adjustable output voltage 1.24V to 10V

Applications

- Opto-coupler linearization
- Linear regulators
- Improved Zener
- Variable reference

Ordering information

Tol.	Order code	Package	Part mark	Status (*)	Reel size	Tape width (mm)	Quantity per reel
1%	ZTLV431AE5TA	SOT23-5	S1A	Preview	7" (180mm)	8	3,000
	ZTLV431AFTA	SOT23	S1A	Active	7" (180mm)	8	3,000
	ZTLV431AFFTA	SOT23F	S1A	Preview	7" (180mm)	8	3,000
0.5%	ZTLV431BE5TA	SOT23-5	S1B	Preview	7" (180mm)	8	3,000
	ZTLV431BFTA	SOT23	S1B	Preview	7" (180mm)	8	3,000
	ZTLV431BFFTA	SOT23F	S1B	Preview	7" (180mm)	8	3,000

NOTES:

(*) For availability of preview status devices contact your local Zetex sales representative

Pin connections

ZTLV431_F (SOT23)
(top view)

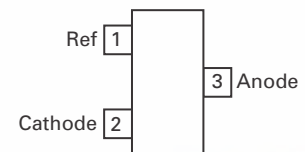

ZTLV431_FF (SOT23F)
(top view)

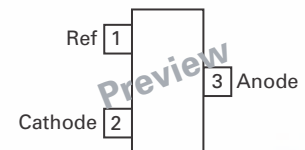

ZTLV431_E5 (SOT23-5)
(top view)

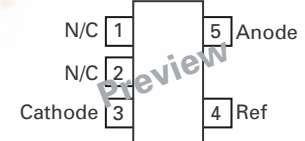

ZTLV431

Absolute maximum ratings

Cathode voltage (V_{KA})	10V
Continuous cathode current (I_{KA})	-20 to 20mA
Reference input current range (I_{REF})	-0.05 to 3mA
Operating junction temperature	-40 to 150°C
Storage temperature	-55 to 150°C

Operation above the absolute maximum rating may cause device failure. Operation at the absolute maximum ratings, for extended periods, may reduce device reliability.

Unless otherwise stated voltages specified are relative to the ANODE pin.

Package thermal data

Package	Θ_{JA}	P_{DIS} $T_A = 25^\circ C$
SOT23-5	250°C/W	500 mW
SOT23	380°C/W	330 mW
SOT23F	160°C/W	780 mW

Recommended operating conditions

	Min.	Max.	Units
V_{KA} cathode voltage	V_{REF}	10	V
I_{KA} cathode current	0.1	15	mA
T_A operating ambient temperature range	-40	125	°C

ZTLV431

Electrical characteristics (electrical characteristics over recommended operating conditions, $T_A = 25^\circ\text{C}$, $K_{KA} = V_{REF}$, $I_{KA} = 10\text{mA}$ unless otherwise stated)

Symbol	Parameter	Conditions	Min.	Typ.	Max.	Units	
V_{REF}	Reference voltage		ZTLV431A	1.228	1.24	1.252	V
			ZTLV431B	1.234	1.24	1.246	
		$T_A = -40$ to 85°C	ZTLV431A	1.215		1.265	
			ZTLV431B	1.224		1.259	
		$T_A = -40$ to 125°C	ZTLV431A	1.209		1.271	
			ZTLV431B	1.221		1.265	
$V_{REF(\text{dev})}$	Deviation of reference voltage over full temperature range	$T_A = 0$ to 70°C		4	12	mV	
		$T_A = -40$ to 85°C		6	20		
		$T_A = -40$ to 125°C		11	31		
$\frac{\Delta V_{REF}}{\Delta V_{KA}}$	Ratio of change in reference voltage to the change in cathode voltage	V_{KA} from V_{REF} to $I_{KA} = 10\text{mA}$	6V		-1.5	-2.7	mV/V
			10V		-1.5	-2.7	
I_{REF}	Reference input current	$I_{KA} = 10\text{mA}$, $R_1 = 10\text{k}\Omega$, $R_2 = \text{OC}$		0.1	0.5	μA	
$I_{REF(\text{dev})}$	I_{REF} deviation over full temperature range	$I_{KA} = 10\text{mA}$, $R_1 = 10\text{k}\Omega$, $R_2 = \text{OC}$	$T_A = 0$ to 70°C		0.05	0.3	μA
			$T_A = -40$ to 85°C		0.1	0.4	
			$T_A = -40$ to 125°C		0.15	0.5	
$I_{K\text{MIN}}$	Minimum cathode current for regulation	$V_{KA} = V_{REF}$	$T_A = -40$ to 125°C		55	100	μA
$I_{K(\text{OFF})}$	Off-state current	$V_{KA} = 10\text{V}$, $V_{REF} = 0\text{V}$		10	30	μA	
Z_{KA}	Dynamic output impedance	$V_{KA} = V_{REF}$, $f < 1\text{kHz}$, $I_K = 0.1$ to 15mA		0.25	0.4	Ω	

Deviation of reference input voltage, V_{DEV} , is defined as the maximum variation of the reference input voltage over the full temperature range.

The average temperature coefficient of the reference input voltage, V_{REF} is defined as:

$$V_{REF} \left(\frac{\text{ppm}}{^\circ\text{C}} \right) = \frac{V_{DEV} \times 1000000}{V_{REF} (T_1 - T_2)}$$

The dynamic output impedance, Z_{KA} , is defined as:

$$Z_{KA} = \frac{\Delta V_K}{\Delta I_K}$$

When the device is programmed with two external resistors, R_1 and R_2 , (fig 2), the dynamic output impedance of the overall circuit, Z' , is defined as:

$$Z' = Z_{KA} \times \left(1 + \frac{R_1}{R_2} \right)$$

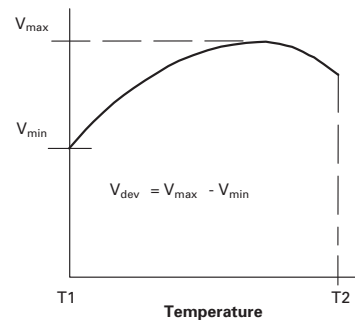

Typical characteristics

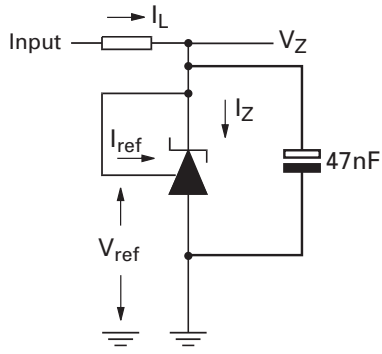

Fig 1 - Test circuit for $V_Z = V_{ref}$

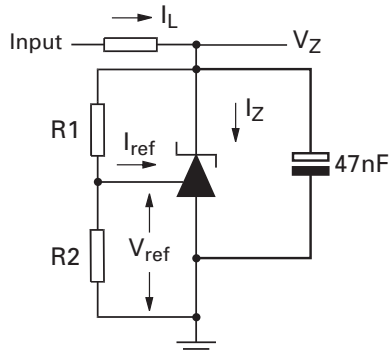

Fig 2 - Test circuit for $V_Z > V_{ref}$

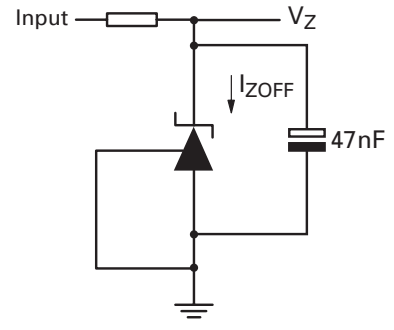

Fig 3 - Test circuit for Off state current[†]

ZTLV431

Intentionally left blank

ZTLV431

Package outline - SOT23

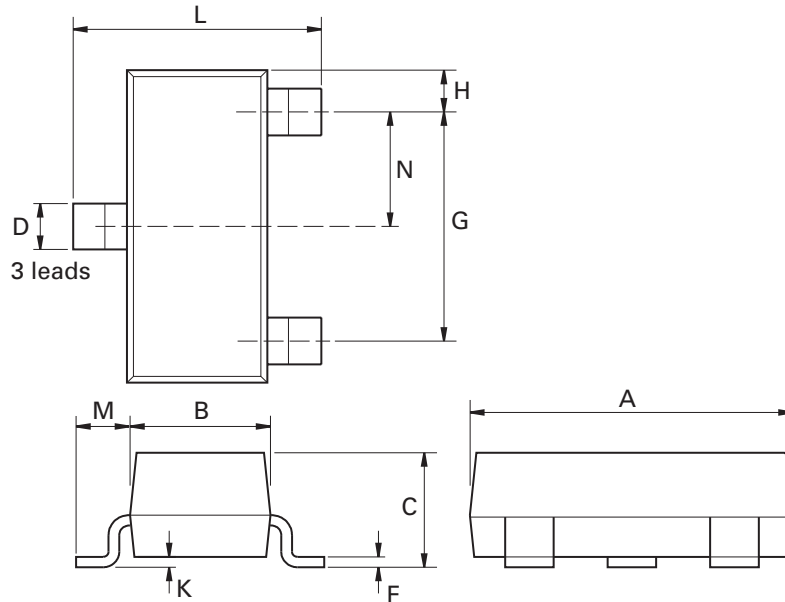

Dim.	Millimeters		Inches		Dim.	Millimeters		Inches	
	Min.	Max.	Min.	Max.		Min.	Max.	Max.	Max.
A	2.67	3.05	0.105	0.120	H	0.33	0.51	0.013	0.020
B	1.20	1.40	0.047	0.055	K	0.01	0.10	0.0004	0.004
C	-	1.10	-	0.043	L	2.10	2.50	0.083	0.0985
D	0.37	0.53	0.015	0.021	M	0.45	0.64	0.018	0.025
F	0.085	0.15	0.0034	0.0059	N	0.95 NOM		0.0375 NOM	
G	1.90 NOM		0.075 NOM		-	-	-	-	-

Note: Controlling dimensions are in millimeters. Approximate dimensions are provided in inches

ZTLV431

Package outline - SOT23F

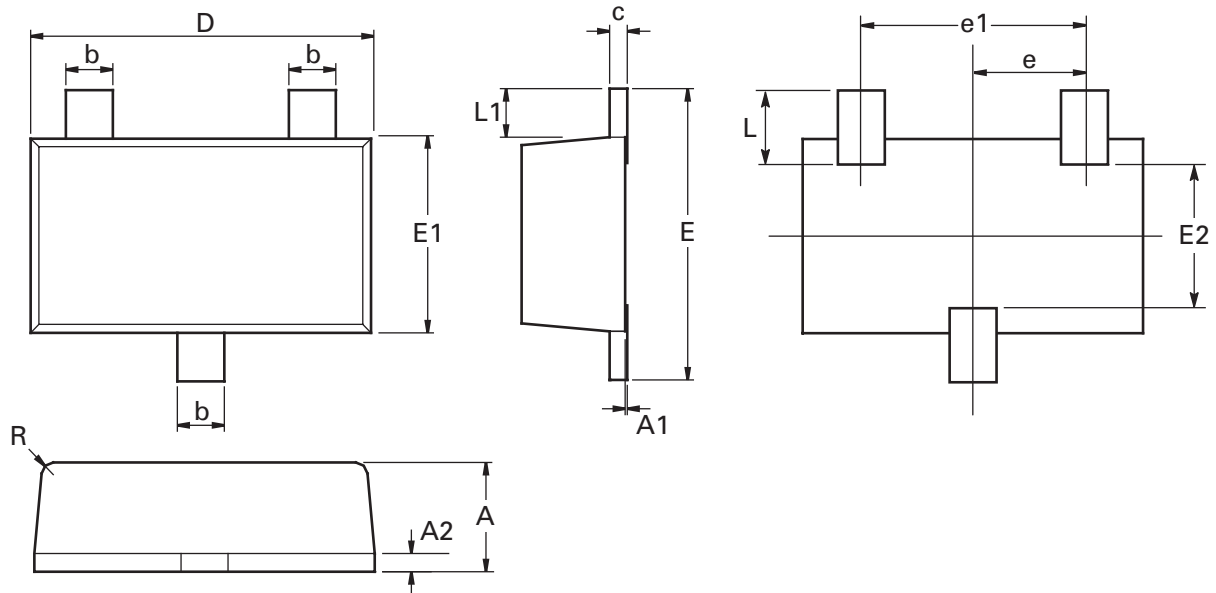

Dim.	Millimeters		Inches		Dim.	Millimeters		Inches	
	Min.	Max.	Min.	Max.		Min.	Max.	Max.	Max.
A	0.80	1.00	0.031	0.0394	E	2.30	2.50	0.0906	0.0984
A1	-	0.10	0.00	0.0043	E1	1.50	1.70	0.0590	0.0669
A2	0.06	0.16	0.0024	0.0006	E2	1.10	1.26	0.0433	0.0496
b	0.39	0.41	0.0153	0.0161	L	0.48	0.68	0.0189	0.0268
c	0.11	0.20	0.0043	0.0079	L1	0.39	0.41	0.0153	0.0161
D	2.80	3.00	0.1102	0.1181	R	0.05	0.15	0.0019	0.0059
e	0.95 ref		0.0374 ref		O	0°	12°	0°	12°
e1	1.90 ref		0.7480 ref		-	-	-	-	-

Note: Controlling dimensions are in millimeters. Approximate dimensions are provided in inches

ZTLV431

Package outline - SOT23-5

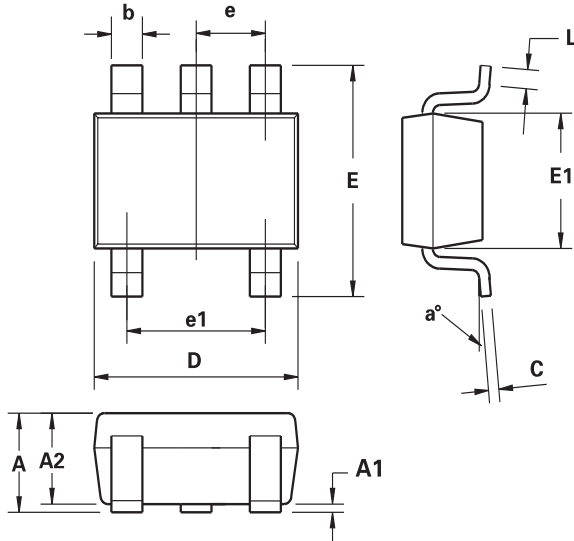

DIM	Millimeters		Inches	
	Min.	Max.	Min.	Max.
A	0.90	1.45	0.0354	0.0570
A1	0.00	0.15	0.00	0.0059
A2	0.90	1.30	0.0354	0.0511
b	0.20	0.50	0.0078	0.0196
C	0.09	0.26	0.0035	0.0102
D	2.70	3.10	0.1062	0.1220
E	2.20	3.20	0.0866	0.1181
E1	1.30	1.80	0.0511	0.0708
e	0.95 REF		0.0374 REF	
e1	1.90 REF		0.0748 REF	
L	0.10	0.60	0.0039	0.0236
a°	0°	30°	0°	30°

Note: Controlling dimensions are in millimeters. Approximate dimensions are provided in inches

Europe

Zetex GmbH
Streitfeldstraße 19
D-81673 München
Germany

Telefon: (49) 89 45 49 49 0
Fax: (49) 89 45 49 49 49
europe.sales@zetex.com

Americas

Zetex Inc
700 Veterans Memorial Highway
Hauppauge, NY 11788
USA

Telephone: (1) 631 360 2222
Fax: (1) 631 360 8222
usa.sales@zetex.com

Asia Pacific

Zetex (Asia Ltd)
3701-04 Metroplaza Tower 1
Hing Fong Road, Kwai Fong
Hong Kong

Telephone: (852) 26100 611
Fax: (852) 24250 494
asia.sales@zetex.com

Corporate Headquarters

Zetex Semiconductors plc
Zetex Technology Park, Chadderton
Oldham, OL9 9LL
United Kingdom

Telephone: (44) 161 622 4444
Fax: (44) 161 622 4446
hq@zetex.com

For international sales offices visit www.zetex.com/offices

Zetex products are distributed worldwide. For details, see www.zetex.com/salesnetwork

This publication is issued to provide outline information only which (unless agreed by the company in writing) may not be used, applied or reproduced for any purpose or form part of any order or contact or be regarded as a representation relating to the products or services concerned. The company reserves the right to alter without notice the specification, design, price or conditions of supply of any product or service.