



ZXCT1030

High-side current monitor with comparator

Description

The ZXCT1030 is a high side current sense monitor containing an internal reference and comparator with a non-latching output. Using this device eliminates the need to disrupt the ground plane when sensing a load current.

The wide input voltage range of 20V down to as low as 2.2V make it suitable for a range of applications. Dynamics and supply current are optimized for the processing of fast pulses, associated with switch mode applications.

Features

- Low cost, accurate high-side current sensing
- Output voltage scaling
- Up to 18V output
- 2.2V - 20V supply range
- 270µA quiescent current
- 1.5% typical accuracy
- SO8 package
- Voltage reference on chip
- Comparator on chip

Applications

- Battery chargers
- Electronic fuse
- DC motor control
- Over current monitor
- Power management
- Inrush current limiting

Typical application circuit

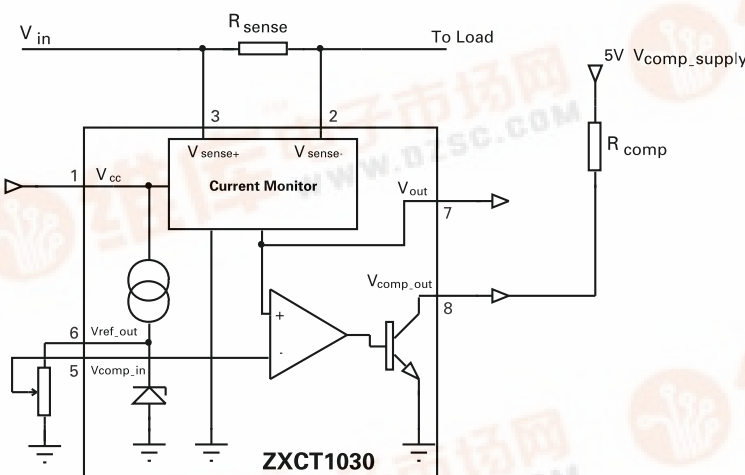

Ordering information

Device	Status	Package	Device marking	Reel size (inches)	Tape width (mm)	Quantity per reel
ZXCT1030X8TA	Last time buy	MSOP8	ZXCT1030	7	12	1000
ZXCT1030N8TA	Preview	SO8	ZXCT1030	7	12	500



ZXCT1030

Absolute maximum ratings

Voltage on any pin	-0.6V and $V_{CC} + 0.6V$
Operating temperature	-40 to 85°C
Storage temperature	-55 to 125°C
Package power dissipation MSOP8	($T_{amb} = 25^{\circ}C$) 500mW

Recommended operating conditions

Parameter	Min.	Max.	Unit
V_{CC}	2.2	20	V
V_{SENSE+}	2.2	V_{CC}	V
$V_{SENSE}^{(a)}$	10	500	mV
V_{OUT}	0	$V_{SENSE} - 1V$	V
$V_{comp-in}$	0.005	10	V
T_{amb}	-40	85	°C

Pin-out connections

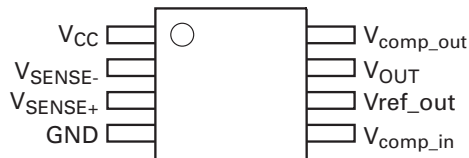

Pin name	Function
V_{CC}	Supply voltage
V_{SENSE-}	Negative sense input
V_{SENSE+}	Positive sense input
GND	Ground
$V_{comp-in}$	Comparator input, usually a ratio of the reference or other control signal
Vref_out	Reference output
V_{OUT}	Current monitor output voltage
$V_{comp-out}$	Open collector comparator output

ZXCT1030

Electrical characteristics (ZXCT1030X8) - Test conditions $T_{amb} = 25^{\circ}\text{C}$, $V_{IN} = V_{CC} = 15\text{V}$, $R_{comp} = 10\text{k}\Omega$, $V_{comp_supply} = 5\text{V}$ unless otherwise stated.

Symbol	Parameter	Conditions	Limits			Unit
			Min.	Typ.	Max.	
V_{CC}	V_{CC} range		2.2		20	V
V_{SENSE+}	Sense+ range		2.2		V_{CC}	
V_{OUT}	Output voltage	$V_{SENSE} = 0\text{V}$	0	2	10	mV
		$V_{SENSE} = 10\text{mV}$	88	100	112	mV
		$V_{SENSE} = 30\text{mV}$	284	300	316	mV
		$V_{SENSE} = 50\text{mV}$	480	500	520	mV
		$V_{SENSE} = 100\text{mV}$	970	1000	1030	mV
		$V_{SENSE} = 500\text{mV}$	4500	5000	5500	mV
R_{OUT}	Output resistance	$V_{SENSE-} = 15\text{V}$, $V_{OUT} = 1\text{V}$	1.2	1.5	1.8	$\text{k}\Omega$
V_{OUT} T_C	V_{OUT} temperature coefficient			30		$\text{ppm}/^{\circ}\text{C}$
I_{CC}	Supply current	$V_{SENSE-} = 15\text{V}$	170	270	350	μA
I_{SENSE+}	V_{SENSE+} input current			48	90	μA
I_{SENSE-}	V_{SENSE-} input current	$V_{SENSE-} = 14.9\text{V}$		70	220	nA
$V_{CM(\text{min})}^{(b)}$	Minimum active common mode voltage	$V_{CC} = 15\text{V}$ $V_{comp_supply} = 5\text{V}$ $V_{comp_in} = V_{REF}$ $V_{SENSE} = 10\text{mV}$	2.8			V
A_{CC}	Accuracy	$V_{SENSE} = 100\text{mV}$	-3		3	%
Gain	V_{OUT} / V_{SENSE}	$V_{SENSE} = 100\text{mV}$	9.7	10.0	10.3	
BW	Bandwidth	$V_{SENSE} = 10\text{mVp-p}$		3		MHz
		$V_{SENSE} = 100\text{mVp-p}$		6		MHz
Comparator						
V_{comp_in}	Input voltage		0.005		10	V
V_H	Hysteresis			15		mV
I_B	Input bias		5	80	150	nA
T_D	Propagation delay			100		ns
V_{OL}	Output voltage low		30	150	200	mV
V_{OH}	Output voltage high				V_{comp_supply}	V
I_{OL}	Output sink current	$V_{OL} = 0.4\text{V}$	2			mA
I_{OH}	Output high leakage current				1.0	μA
Voltage reference						
V_{ref}		Reference current = $+300\mu\text{A}$ to $-5\mu\text{A}$	1.200	1.240	1.280	V
delta V_{ref}	Change in V_{ref}	$I_{source} 5\mu\text{A}$ to $I_{sink} 300\mu\text{A}$		10		mV
T_C				30		$\text{ppm}/^{\circ}\text{C}$
PSR	Supply rejection			0.01		$\%/V$

NOTES:

(a) $V_{SENSE} = (V_{SENSE+}) - (V_{SENSE-})$

(b) Level of V_{SENSE+} where comparator output defaults to 'off'.

ZXCT1030

Electrical characteristics (ZXCT1030N8) - Test conditions $T_{amb} = 25^{\circ}\text{C}$, $V_{IN} = V_{CC} = 15\text{V}$, $R_{comp} = 10\text{k}\Omega$, $V_{comp_supply} = 5\text{V}$ unless otherwise stated.

Symbol	Parameter	Conditions	Limits			Unit
			Min.	Typ.	Max.	
V_{CC}	V_{CC} range		2.2		20	V
V_{SENSE+}	Sense+ range		2.2		V_{CC}	
V_{OUT}	Output voltage	$V_{SENSE} = 0\text{V}$	0	2	10	mV
		$V_{SENSE} = 10\text{mV}$	88	100	112	mV
		$V_{SENSE} = 30\text{mV}$	284	300	316	mV
		$V_{SENSE} = 50\text{mV}$	480	500	520	mV
		$V_{SENSE} = 100\text{mV}$	970	1000	1030	mV
		$V_{SENSE} = 500\text{mV}$	4500	5000	5500	mV
R_{OUT}	Output resistance	$V_{SENSE-} = 15\text{V}$, $V_{OUT} = 1\text{V}$	1.2	1.5	1.8	$\text{k}\Omega$
V_{OUT} T_C	V_{OUT} temperature coefficient			30		$\text{ppm}/^{\circ}\text{C}$
I_{CC}	Supply current	$V_{SENSE-} = 15\text{V}$	170	270	350	μA
I_{SENSE+}	V_{SENSE+} input current			48	90	μA
I_{SENSE-}	V_{SENSE-} input current	$V_{SENSE-} = 14.9\text{V}$		70	220	nA
$V_{CM(\text{min})}^{(b)}$	Minimum active common mode voltage	$V_{CC} = 15\text{V}$ $V_{comp_supply} = 5\text{V}$ $V_{comp_in} = V_{REF}$ $V_{SENSE} = 10\text{mV}$	2.8			V
A_{CC}	Accuracy	$V_{SENSE} = 100\text{mV}$	-3		3	%
Gain	V_{OUT} / V_{SENSE}	$V_{SENSE} = 100\text{mV}$	9.7	10.0	10.3	
BW	Bandwidth	$V_{SENSE} = 10\text{mVp-p}$		3		MHz
		$V_{SENSE} = 100\text{mVp-p}$		6		MHz
Comparator						
V_{comp_in}	Input voltage		0.005		10	V
V_H	Hysteresis			15		mV
I_B	Input bias		5	80	150	nA
T_D	Propagation delay			100		ns
V_{OL}	Output voltage low		30	150	200	mV
V_{OH}	Output voltage high				V_{comp_supply}	V
I_{OL}	Output sink current	$V_{OL} = 0.4\text{V}$	2			mA
I_{OH}	Output high leakage current				1.0	μA
Voltage reference						
V_{ref}		Reference current = $+300\mu\text{A}$ to $-5\mu\text{A}$	1.200	1.240	1.280	V
delta V_{ref}	Change in V_{ref}	$I_{source} 5\mu\text{A}$ to $I_{sink} 300\mu\text{A}$		10		mV
T_C				30		$\text{ppm}/^{\circ}\text{C}$
PSR	Supply rejection			0.01		$\%/V$

NOTES:

(c) $V_{SENSE} = (V_{SENSE+}) - (V_{SENSE-})$

(d) Level of V_{SENSE+} where comparator output defaults to 'off'.

Typical characteristics

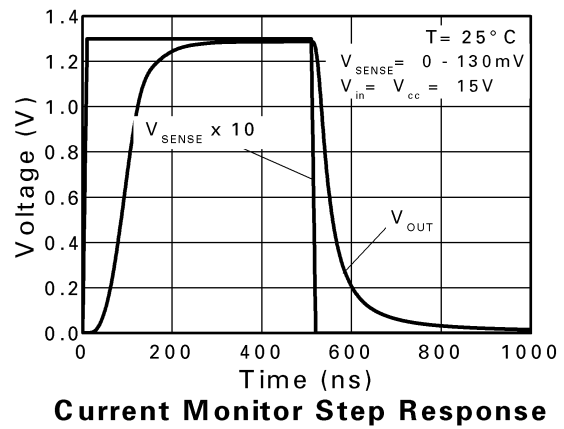
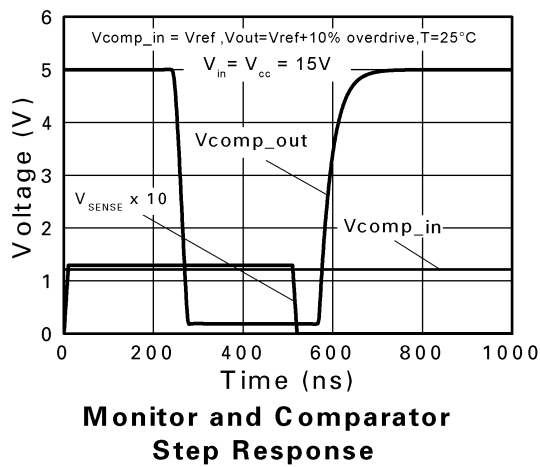
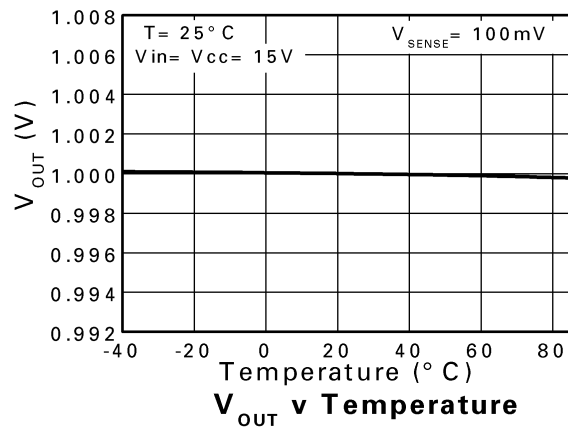
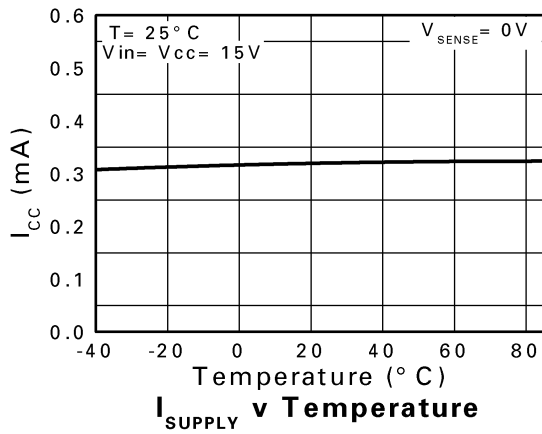
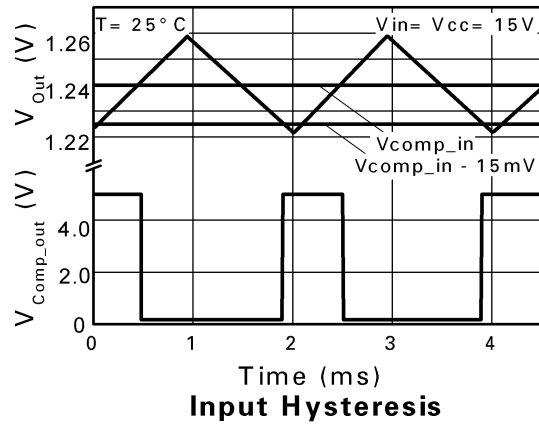
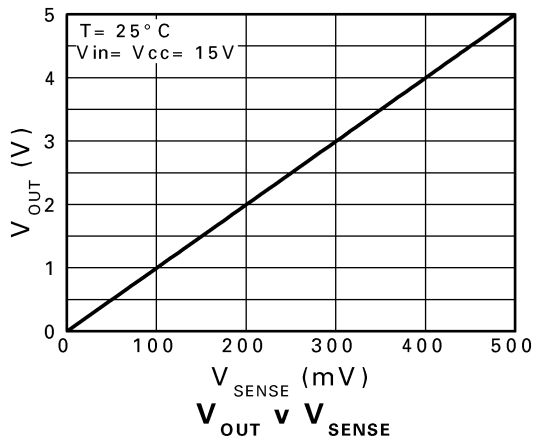

Voltage output current monitor

Referring to the block diagram, the current monitor takes the small voltage developed across the sense resistor (V_{SENSE}) and transfers it from the large common mode supply voltage to a ground-referenced signal with a gain of 10. The sense input common mode range is 2.2V to 20V. In this range, a linear output voltage is delivered.

Reference

The bandgap reference allows the comparator to compare the translated V_{sense} with threshold value chosen by the user which can be any voltage from 0 to 1.24V, configured by two external resistors which forms V_{comp_in} .

The output current which can be drawn from the comparator reference (I_{ref} source) is limited to 5 μ A, making potentiometers $\geq 250k\Omega$ suitable for setting a threshold level. Where a lower potentiometer resistor value is used, an additional resistor value should be inserted between V_{ref} and V_{CC} to maintain sufficient current for the reference. (as shown in Figure 1).

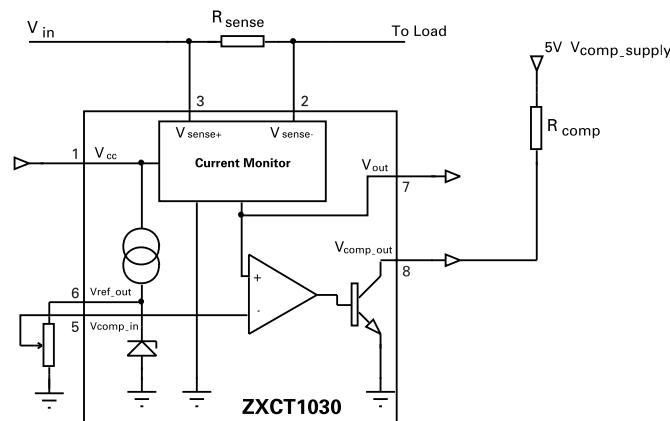

Figure 1: External resistor for reference level

The voltage reference has a maximum current sink capability. This magnitude of current will be influenced by the value of R_1 which is inserted between V_{ref} and V_{CC} . The value of current flowing through R_1 can be expressed as:

$$I = (V_{CC} - V_{ref}) / R_1$$

Comparator

The open collector output is active low and is asserted when $V_{SENSE} \times 10 (V_{OUT}) > V_{comp_in}$.

It can be connected to any voltage rail up to V_{in} via a pull-up resistor. Suggest values for the resistor are in the range of 10-100k Ω .

In the case where high load currents or a short circuit occurs, thus reducing the common mode signals (V_+ , V_-) typically below 2.2V, the comparator will default to the asserted state. This can eliminate a closed loop system 'latch-up' condition, allowing the controller to remove the applied power.

Stability

To ensure stable operation of the ZXCT1030, it is recommended a decoupling capacitor is placed across the V_{CC} and ground connections. A ceramic 10 μ F will be adequate.

ZXCT1030

Intentionally left blank

ZXCT1030

Package outline - S08

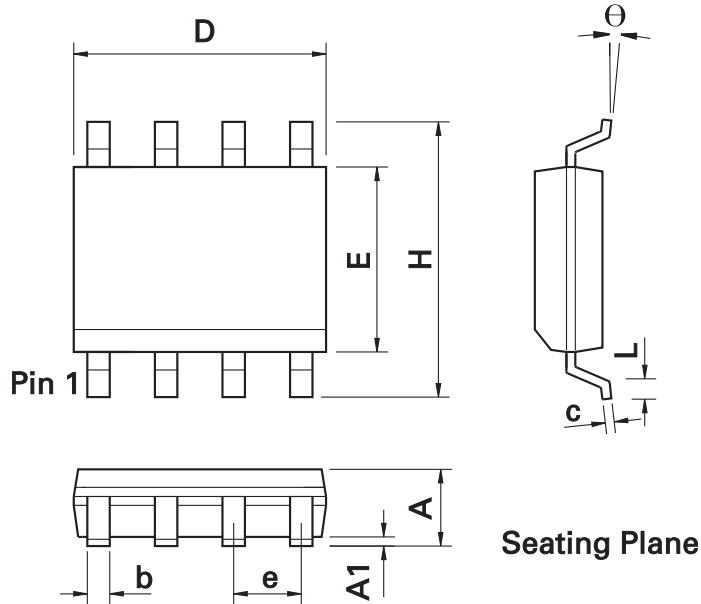

DIM	Inches		Millimeters		DIM	Inches		Millimeters	
	Min.	Max.	Min.	Max.		Min.	Max.	Min.	Max.
A	0.053	0.069	1.35	1.75	e	0.050 BSC		1.27 BSC	
A1	0.004	0.010	0.10	0.25	b	0.013	0.020	0.33	0.51
D	0.189	0.197	4.80	5.00	c	0.008	0.010	0.19	0.25
H	0.228	0.244	5.80	6.20	Θ	0°	8°	0°	8°
E	0.150	0.157	3.80	4.00	h	0.010	0.020	0.25	0.50
L	0.016	0.050	0.40	1.27	-	-	-	-	-

Note: Controlling dimensions are in inches. Approximate dimensions are provided in millimeters

ZXCT1030

Package outline - MSOP8

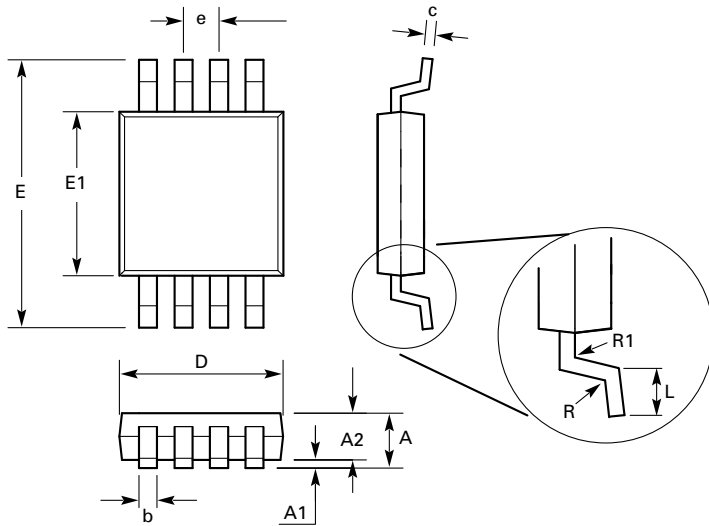

DIM	Millimeters		Inches	
	Min.	Max.	Min.	Max.
A	-	1.10	-	0.0433
A1	0.05	0.15	0.002	0.006
A2	0.75	0.95	0.0295	0.0374
b	0.25	0.40	0.010	0.0157
c	0.13	0.23	0.005	0.009
D	2.90	3.10	0.114	0.122
E	4.90 BSC		0.193 BSC	
E1	2.90	3.10	0.114	0.122
e	0.65 BSC		0.025 BSC	
L	0.40	0.70	0.0157	0.0192
R	0.07	-	0.0027	-
R1	0.07	-	0.0027	-

Note: Controlling dimensions are in millimeters. Approximate dimensions are provided in inches

Definitions

Product change

Zetex Semiconductors reserves the right to alter, without notice, specifications, design, price or conditions of supply of any product or service. Customers are solely responsible for obtaining the latest relevant information before placing orders.

Applications disclaimer

The circuits in this design/application note are offered as design ideas. It is the responsibility of the user to ensure that the circuit is fit for the user's application and meets with the user's requirements. No representation or warranty is given and no liability whatsoever is assumed by Zetex with respect to the accuracy or use of such information, or infringement of patents or other intellectual property rights arising from such use or otherwise. Zetex does not assume any legal responsibility or will not be held legally liable (whether in contract, tort (including negligence), breach of statutory duty, restriction or otherwise) for any damages, loss of profit, business, contract, opportunity or consequential loss in the use of these circuit applications, under any circumstances.

Life support

Zetex products are specifically not authorized for use as critical components in life support devices or systems without the express written approval of the Chief Executive Officer of Zetex Semiconductors plc. As used herein:

A. Life support devices or systems are devices or systems which:

1. are intended to implant into the body

or

2. support or sustain life and whose failure to perform when properly used in accordance with instructions for use provided in the labelling can be reasonably expected to result in significant injury to the user.

B. A critical component is any component in a life support device or system whose failure to perform can be reasonably expected to cause the failure of the life support device or to affect its safety or effectiveness.

Reproduction

The product specifications contained in this publication are issued to provide outline information only which (unless agreed by the company in writing) may not be used, applied or reproduced for any purpose or form part of any order or contract or be regarded as a representation relating to the products or services concerned.

Terms and Conditions

All products are sold subjects to Zetex' terms and conditions of sale, and this disclaimer (save in the event of a conflict between the two when the terms of the contract shall prevail) according to region, supplied at the time of order acknowledgement.

For the latest information on technology, delivery terms and conditions and prices, please contact your nearest Zetex sales office.

Quality of product

Zetex is an ISO 9001 and TS16949 certified semiconductor manufacturer.

To ensure quality of service and products we strongly advise the purchase of parts directly from Zetex Semiconductors or one of our regionally authorized distributors. For a complete listing of authorized distributors please visit: www.zetex.com/salesnetwork

Zetex Semiconductors does not warrant or accept any liability whatsoever in respect of any parts purchased through unauthorized sales channels.

ESD (Electrostatic discharge)

Semiconductor devices are susceptible to damage by ESD. Suitable precautions should be taken when handling and transporting devices. The possible damage to devices depends on the circumstances of the handling and transporting, and the nature of the device. The extent of damage can vary from immediate functional or parametric malfunction to degradation of function or performance in use over time. Devices suspected of being affected should be replaced.

Green compliance

Zetex Semiconductors is committed to environmental excellence in all aspects of its operations which includes meeting or exceeding regulatory requirements with respect to the use of hazardous substances. Numerous successful programs have been implemented to reduce the use of hazardous substances and/or emissions.

All Zetex components are compliant with the RoHS directive, and through this it is supporting its customers in their compliance with WEEE and ELV directives.

Product status key:

"Preview"	Future device intended for production at some point. Samples may be available
"Active"	Product status recommended for new designs
"Last time buy (LTB)"	Device will be discontinued and last time buy period and delivery is in effect
"Not recommended for new designs"	Device is still in production to support existing designs and production
"Obsolete"	Production has been discontinued

Datasheet status key:

"Draft version"	This term denotes a very early datasheet version and contains highly provisional information, which may change in any manner without notice.
"Provisional version"	This term denotes a pre-release datasheet. It provides a clear indication of anticipated performance. However, changes to the test conditions and specifications may occur, at any time and without notice.
"Issue"	This term denotes an issued datasheet containing finalized specifications. However, changes to specifications may occur, at any time and without notice.

Zetex sales offices

Europe	Americas	Asia Pacific	Corporate Headquarters
Zetex GmbH Kustermann-park Balanstraße 59 D-81541 München Germany Telefon: (49) 89 45 49 49 0 Fax: (49) 89 45 49 49 49 europe.sales@zetex.com	Zetex Inc 700 Veterans Memorial Highway Hauppauge, NY 11788 USA Telephone: (1) 631 360 2222 Fax: (1) 631 360 8222 usa.sales@zetex.com	Zetex (Asia Ltd) 3701-04 Metroplaza Tower 1 Hing Fong Road, Kwai Fong Hong Kong Telephone: (852) 26100 611 Fax: (852) 24250 494 asia.sales@zetex.com	Zetex Semiconductors plc Zetex Technology Park, Chadderton Oldham, OL9 9LL United Kingdom Telephone: (44) 161 622 4444 Fax: (44) 161 622 4446 hq@zetex.com

© 2007 Published by Zetex Semiconductors plc