

OMRON

Z4D-A01

Micro-displacement Sensor

■ Dimensions

Note: All units are in millimeters unless otherwise indicated.

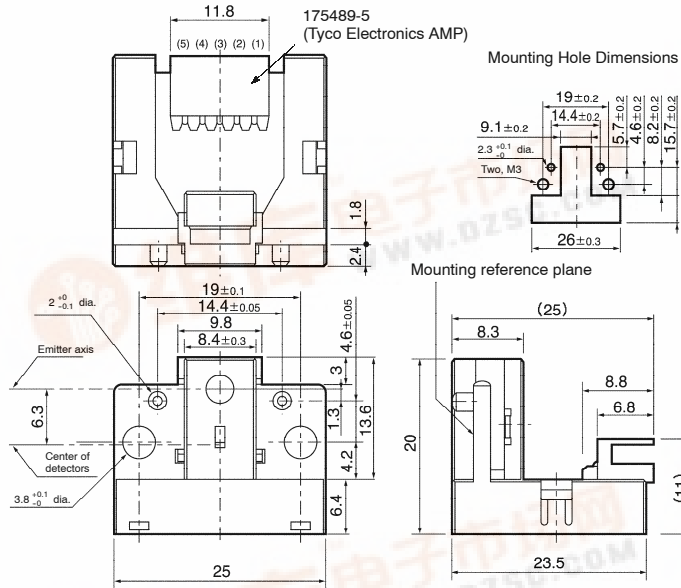

■ Features

- Uses position sensing diode/LED to detect 10 μm movement.
- Sensor output minimally affected by color and reflection of an object.
- Requires 5 VDC to give two analog outputs to the microprocessor with a 10-bit A/D converter.

Pin no.	Remarks	Name
1	V _{CC}	Power supply (V _{CC})
2	O1	Output (OUT1)
3	G	Ground (GND)
4	O2	Output (OUT2)
5	V _B	LED emission control signal

Unless otherwise specified, the tolerances are as shown below.

Dimensions	Tolerance
3 mm max.	±0.3
3 < mm ≤ 6	±0.375
6 < mm ≤ 10	±0.45
10 < mm ≤ 18	±0.55
18 < mm ≤ 30	±0.65

Recommended Mating Connectors:
Tyco Electronics AMP

- 175778-5 (crimp-type connector)
- 179228-5 (crimp-type connector)
- 173977-5 (press-fit connector)

■ Ordering Information

Description	Part number
Micro-displacement sensor	Z4D-A01

■ Absolute Maximum Ratings (Ta = 25°C)

Item	Symbol	Value	Unit	Remarks
Supply voltage	V _{CC}	7	VDC	---
LED emission control signal	V _B	7	VDC	Supply voltage for transistor base terminal
LED emission pulse	t _{FP}	100	ms	Duty cycle: 1% max.
Operating temperature	T _{opr}	-10 to 55	°C	(see note)
Storage temperature	T _{stg}	-25 to 65	°C	---

Note: The product must be used in applications where neither freezing nor condensation takes place.

■ Electrical and Optical Characteristics (Ta = -10°C to 55°C)

Item	Limits	Remarks
Supply voltage	5 VDC±10%	Ripple (p-p): 10 mV p-p max.
Consumption current	200 mA max. 5 mA max.	When LED is ON When LED is OFF
V ₁ , V ₂	3.9 V max.	Common to two signals (see notes 1 and 2)
Response time	100 μs max.	PSD rising time

- Note: 1. When the measured surface of an object is a diffused surface (rough surface)
2. Please make impedance of signal input side a minimum of 10 kΩ.



■ Characteristics (Ta = -10°C to 55°C)

Item	Values (see note 2)	Remarks
Operating distance	6.5±1 mm	From the reference mounting surface
Variation of sensitivity	±10%	(see note 3)
Resolution	±10 μm	(see note 4)
Operable ambient illumination	3,000 lx max. 2,000 lx max.	Under sunlight Under fluorescent lamp

Note: 1. As measured between sensor and microprocessor.

2. The values are measured with a white paper having a 90% reflection factor.

3. Defined as the variation of sensitivity between products. The variation is the change of the calculated analog output by distance (slope of the straight output line.) Refer to "Microprocessor Divided Output vs. Distance" graph in Engineering Data.

4. The resolution means the electrical noise width on the calculated analog output converted into distance when using a 10-bit or more A/D converter.

■ Circuit Diagram

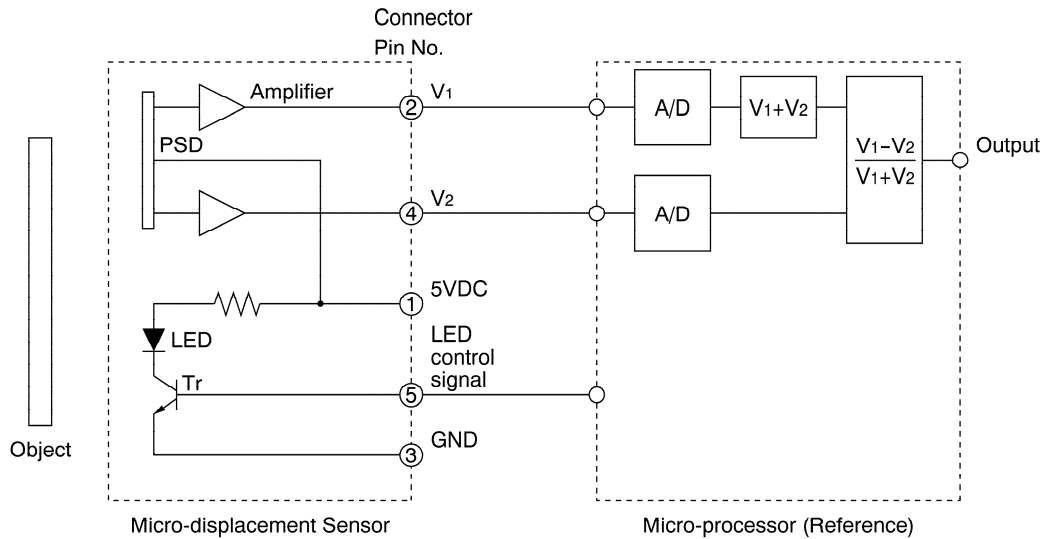

■ Engineering Data

Temperature Characteristics (Typical)

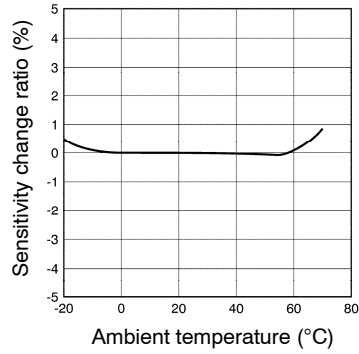

Pulsed Forward Current Rated Curve

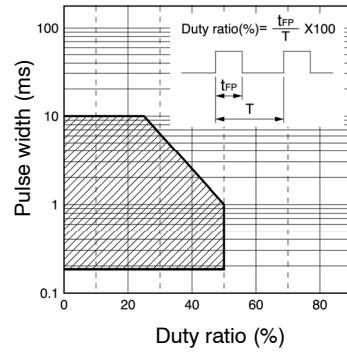

Dependency of Object on Reflection Factor (Typical)

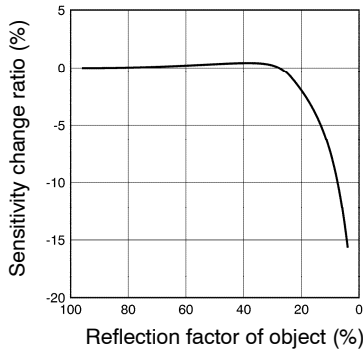

Z4D-A01 Sensor Output vs. Distance (Typical)

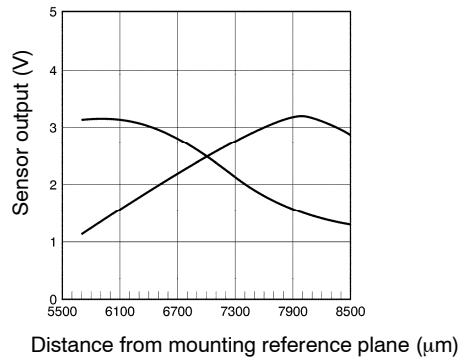

Microprocessor Divided Output vs. Distance (Typical)

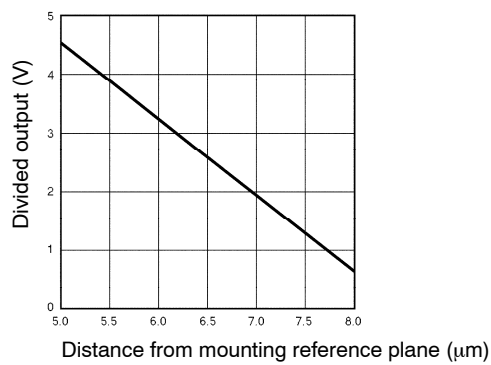

■ Typical Application

Paper thickness detection for printers

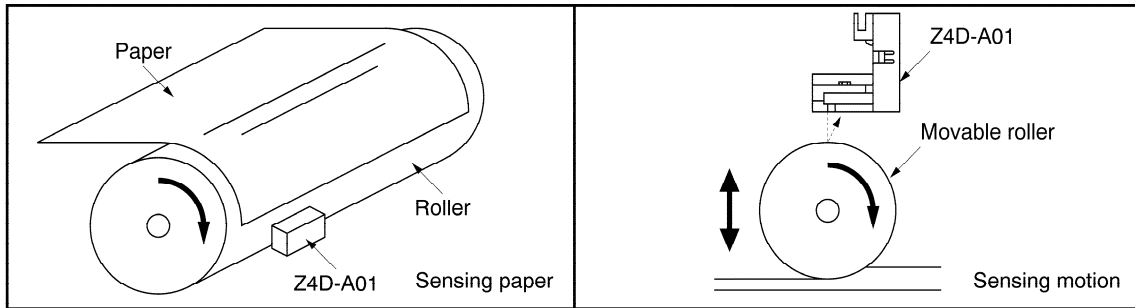

■ Technical Information

This product, developed for use in electronic equipment, is an optical displacement sensor that uses a position-sensitive detector (PSD). The following features are characteristic of the optical displacement sensor when directly connected to a microprocessor provided by the user.

1. The color or the reflection factor of a sensing object has little effect on the analog output.
2. The inclined face of a sensing object has little effect on the analog output.
3. Linear compensation is not required

Internal Configuration

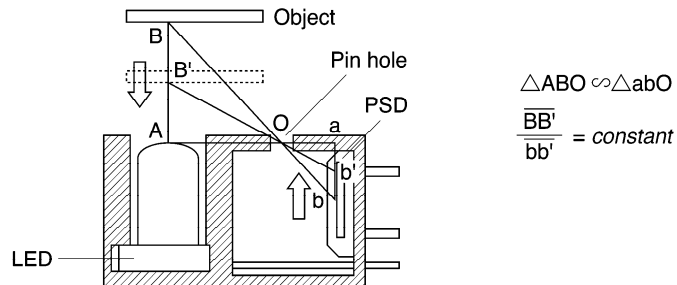

NOTE: DIMENSIONS SHOWN ARE IN MILLIMETERS. To convert millimeters to inches divide by 25.4.

OMRON®

OMRON ELECTRONICS LLC
One East Commerce Drive
Schaumburg, IL 60173
847-882-2288

OMRON CANADA, INC.
885 Milner Avenue
Toronto, Ontario M1B 5V8
416-286-6465

OMRON ON-LINE

Global – <http://www.omron.com>
USA – <http://www.omron.com/oei>
Canada – <http://www.omron.com/oci>