

7-33-09

ACRIAN INC

97 DE 0182998 0001253 0

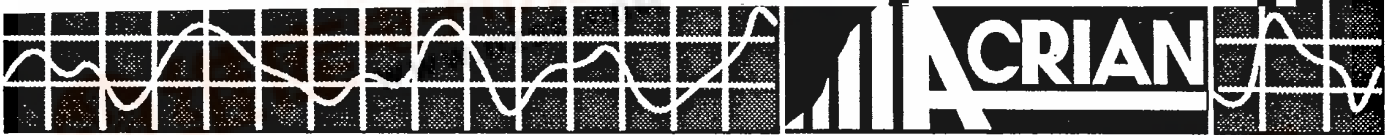

GENERAL DESCRIPTION

The B12-28 is specifically designed for VHF broadband linear power amplifier applications in the 100-200 MHz range. The device is capable of operation in Class A, AB, or C amplifiers and provides the maximum power output/power gain combination.

B12-28 (2N6198)

12 WATTS - 28 VOLTS
100-200 MHz

VHF COMMUNICATIONS

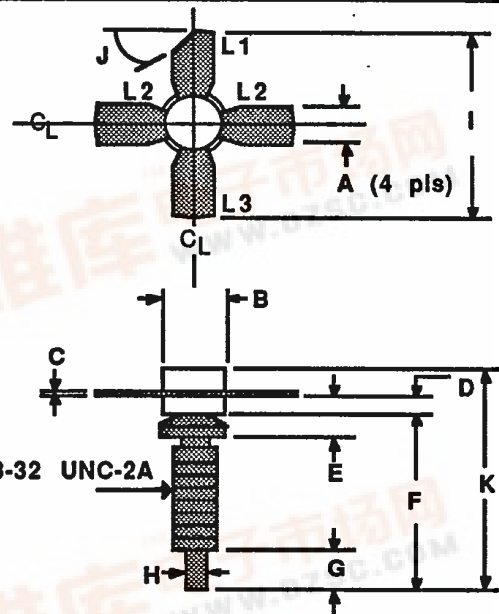

ABSOLUTE MAXIMUM RATINGS

Maximum Power Dissipation @ 25°C Case Temperature	25 W
Maximum Voltage and Current	
BVces Collector to Emitter Voltage	60 V
BVebo Emitter to Base Voltage	4 V
Ic Collector Current	2.5 A
Maximum Temperatures	
Storage Temperature	-65 to +150 °C
Operating Junction Temperature	+200 °C

DIM	Millimeter	TOL	Inches	TOL	
L1 : C	A	5.71	.13	.225	.005
L2 : E	B	9.52 DIA	.13	.375 DIA	.005
L3 : B	C	0.13	.02	.005	.001
	D	1.78	.13	.070	.005
	E	4.06	.13	.160	.005
	F	14.59	.25	.585	.010
	G	3.30	.13	.130	.005
	H	1.52	.13	.060	.005
	I	25.40	.25	1.000	.010
	J	45°	5°	45°	5°
	K	19.00	REF	.748	REF

POWER OUTPUT VS POWER INPUT (TYPICAL)

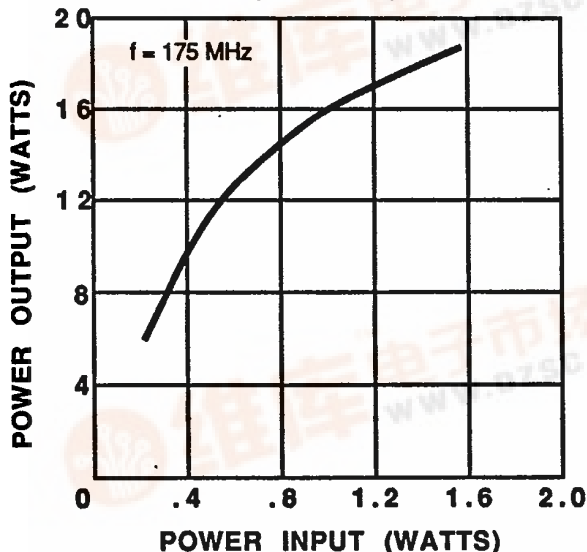

TYPICAL AMPLIFIER LINE UP
Vcc = 28 Volts
Frequency Range = 100-175 MHz

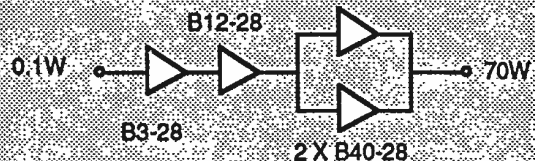

ELECTRICAL CHARACTERISTICS¹

SYMBOL	CHARACTERISTICS	TEST CONDITIONS	MIN.	TYP.	MAX.	UNITS
P _{out}	Power Output	f=175 MHz V _{cc} = 28V	12			Watts
P _{in}	Power Input				1.0	Watts
P _g	Power Gain		10.8	13		dB
η _c	Collector Efficiency			60		%
VSWR	Load Mismatch Tolerance				∞:1	
B _{Vebo}	Breakdown Voltage (Emitter to Base)	I _c = 0A, I _e = 5mA	4.0			Volts
B _{Vces}	Breakdown Voltage (Collector to Emitter)	V _{be} = 0A, I _c = 5mA	60			Volts
B _{Vceo}	Breakdown Voltage (Collector to Emitter)	I _b = 0A, I _c = 50mA	35			Volts
C _{ob}	Capacitance-Collector to Base	V _{cb} = 28V, f= 1 MHz		25		pF
h _{FE}	DC-Current Gain	V _{ce} = 5V, I _c = 1A	10			
θ _{jc}	Thermal Resistance				7.0	°C/W

Note 1: T_c = +25°C unless otherwise specified

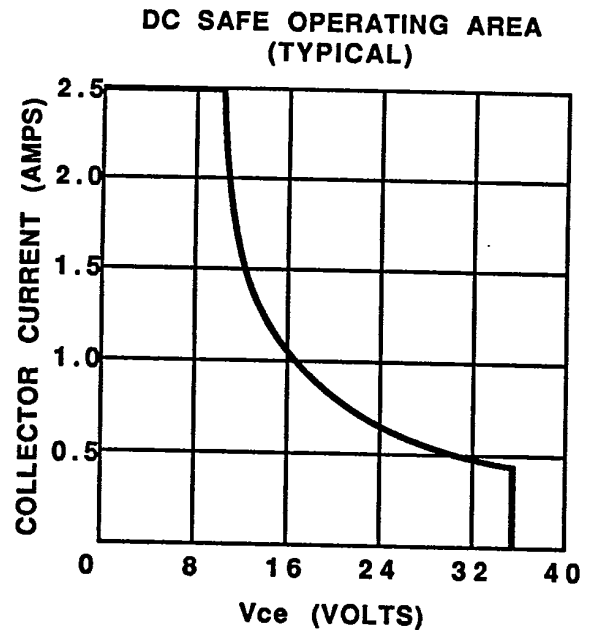
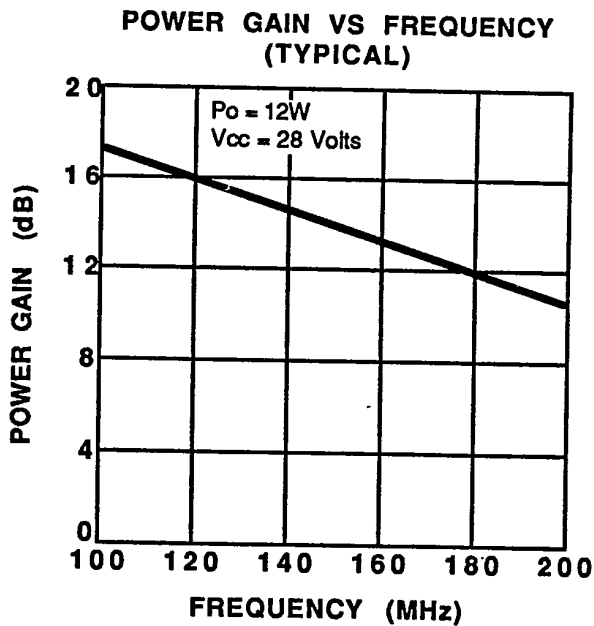

236