

# 2SC5077, 2SC5077A

Silicon NPN triple diffusion planar type

For high breakdown voltage high-speed switching

### Features

- High-speed switching
- High collector to base voltage  $V_{CBO}$
- Wide area of safe operation (ASO)
- Satisfactory linearity of forward current transfer ratio  $h_{FE}$
- Full-pack package with outstanding insulation, which can be installed to the heat sink with one screw

### Absolute Maximum Ratings ( $T_C=25^\circ\text{C}$ )

Parameter	Symbol	Rated	Unit
Collector to base voltage	$V_{CBO}$	800	V
2SC5077			
2SC5077A		900	
Collector to emitter voltage	$V_{CES}$	800	V
2SC5077			
2SC5077A		900	
Collector to emitter voltage	$V_{CEO}$	500	V
Emitter to base voltage	$V_{EBO}$	8	V
Peak collector current	$I_{CP}$	15	A
Collector current	$I_C$	7	A
Base current	$I_B$	4	A
Collector power dissipation	$P_C$	45	W
$T_C=25^\circ\text{C}$			
$T_a=25^\circ\text{C}$		2	
Junction temperature	$T_j$	150	$^\circ\text{C}$
Storage temperature	$T_{stg}$	-55 to +150	$^\circ\text{C}$

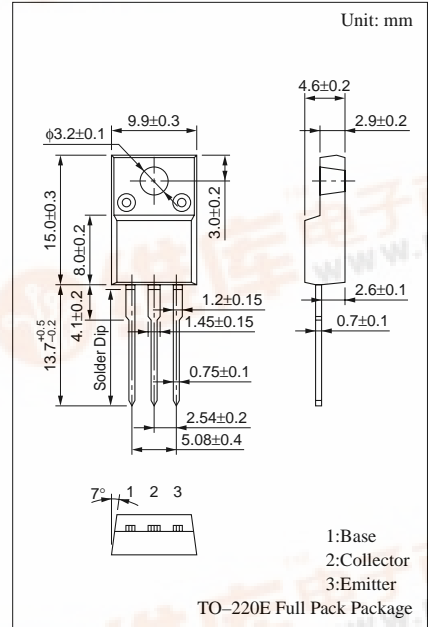

### Electrical Characteristics ( $T_C=25^\circ\text{C}$ )

Parameter	Symbol	Conditions	min	typ	max	Unit
Collector cutoff current	$I_{CBO}$	$V_{CB} = 800\text{V}, I_E = 0$			100	$\mu\text{A}$
2SC5077						
2SC5077A		$V_{CB} = 900\text{V}, I_E = 0$			100	
Emitter cutoff current	$I_{EBO}$	$V_{EB} = 5\text{V}, I_C = 0$			100	$\mu\text{A}$
Collector to emitter voltage	$V_{CEO}$	$I_C = 10\text{mA}, I_B = 0$	500			$\mu\text{A}$
Forward current transfer ratio	$h_{FE1}$	$V_{CE} = 5\text{V}, I_C = 0.1\text{A}$	15			V
	$h_{FE2}$	$V_{CE} = 5\text{V}, I_C = 4\text{A}$	8			
Collector to emitter saturation voltage	$V_{CE(sat)}$	$I_C = 4\text{A}, I_B = 0.8\text{A}$			1.0	V
Base to emitter saturation voltage	$V_{BE(sat)}$	$I_C = 4\text{A}, I_B = 0.8\text{A}$			1.5	V
Transition frequency	$f_T$	$V_{CE} = 10\text{V}, I_C = 0.5\text{A}, f = 1\text{MHz}$			1.0	MHz
Turn-on time	$t_{on}$	$I_C = 4\text{A}, I_{B1} = 0.8\text{A}, I_{B2} = -1.6\text{A}, V_{CC} = 200\text{V}$			1.0	$\mu\text{s}$
Storage time	$t_{stg}$				3.0	$\mu\text{s}$
Fall time	$t_f$				0.3	$\mu\text{s}$

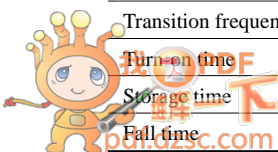

$P_C - T_a$

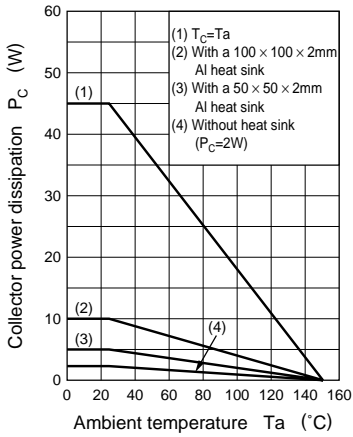

$I_C - V_{CE}$

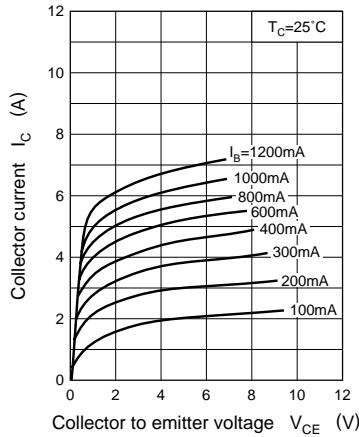

$V_{CE(sat)} - I_C$

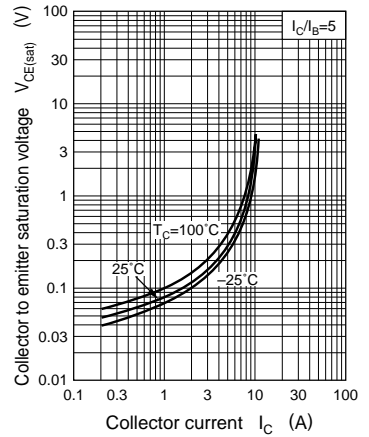

$V_{BE(sat)} - I_C$

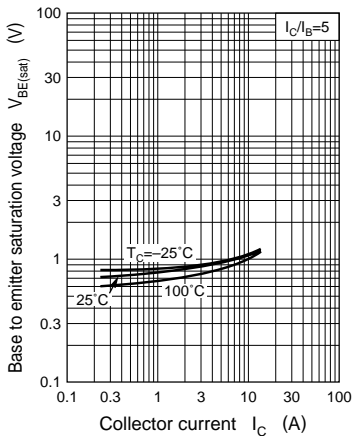

$h_{FE} - I_C$

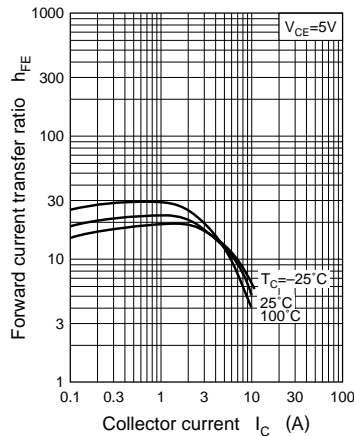

$f_T - I_C$

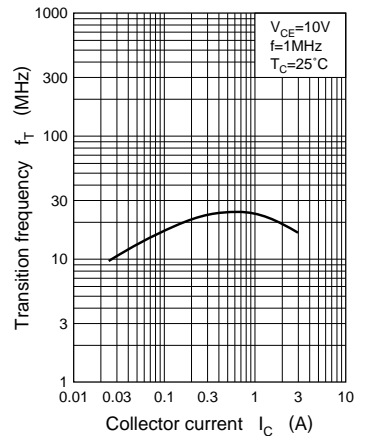

$C_{ob} - V_{CB}$

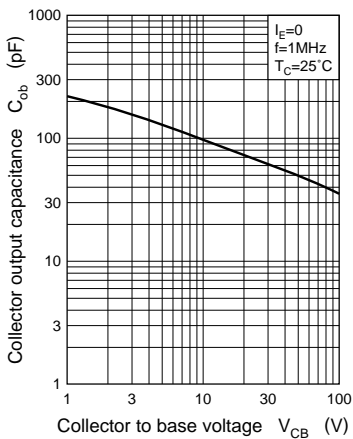

$t_{on}, t_{stg}, t_f - I_C$

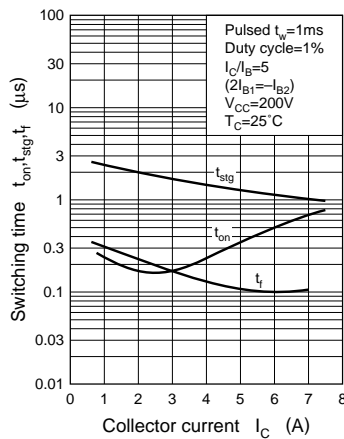

Area of safe operation (ASO)

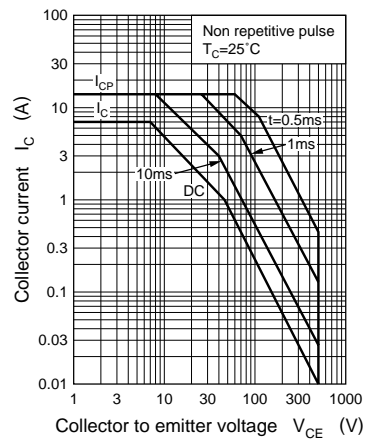

Area of safe operation, reverse bias ASO

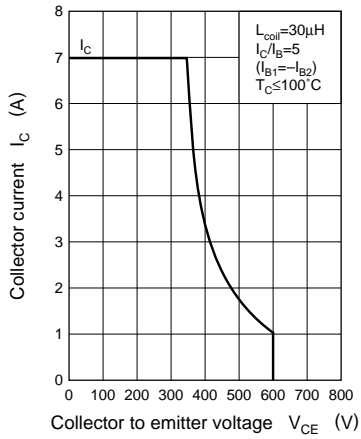

Reverse bias ASO measuring circuit

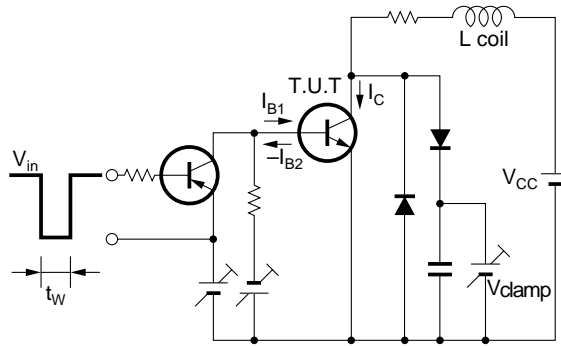

$R_{th(t)} - t$

