

2SC3200

香港2SC3200供应商

SILICON NPN TRANSISTOR EPITAXIAL PLANAR TYPE (PCT PROCESS)

建家邦 专业PCB打样 14小时加急出货

APPLICATIONS

- Low Noise Audio Amplifier Applications.

FEATURES

The 2SC3200 is a transistor for low frequency and low noise applications. This device is designed to lower noise figure in the region of low signal source impedance, and to lower the pulse noise.

This is recommended for the first stages of EQ amplifiers.

- Low Noise
 - :NF=4dB(Typ.), $R_g=100\Omega$, $V_{CE}=6V$, $I_C=100\mu A$, $f=1KHz$
 - :NF=0.5dB(Typ.), $R_g=1K\Omega$, $V_{CE}=6V$, $I_C=100\mu A$, $f=1KHz$
- Low Pulse Noise: Low 1/f Noise
- High DC Current Gain: $h_{FE}=200\sim 700$
- High Breakdown Voltage: $V_{CEO}=120V$

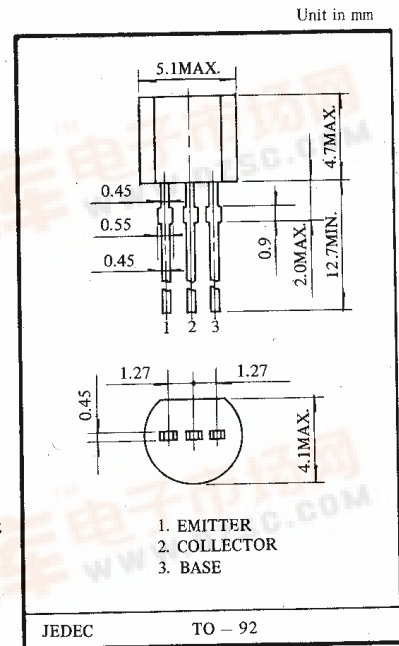

MAXIMUM RATINGS (Ta=25°C)

CHARACTERISTIC	SYMBOL	RATING	UNIT	CHARACTERISTIC	SYMBOL	RATING	UNIT
Collector-Base Voltage	V_{CBO}	120	V	Emitter Current	I_E	-100	mA
Collector-Emitter Voltage	V_{CEO}	120	V	Collector Power Dissipation	P_C	300	mW
Emitter-Base Voltage	V_{EBO}	5	V	Junction Temperature	T_j	125	°C
Collector Current	I_C	100	mA	Storage Temperature Range	T_{stg}	-55~125	°C

ELECTRICAL CHARACTERISTICS (Ta=25°C)

CHARACTERISTIC	SYMBOL	TEST CONDITION	MIN.	TYP.	MAX.	UNIT
Collector Cut-off Current	I_{CBO}	$V_{CB}=120V, I_E=0$	—	—	100	nA
Emitter Cut-off Current	I_{EBO}	$V_{EB}=5V, I_C=0$	—	—	100	nA
Collector-Emitter Breakdown Voltage	$V_{(BR)CEO}$	$I_C=1mA, I_B=0$	120	—	—	V
DC Current Gain	$h_{FE}(\text{Note})$	$V_{CE}=6V, I_C=2mA$	200	—	700	
Collector-Emitter Saturation Voltage	$V_{CE(sat)}$	$I_C=10mA, I_B=1mA$	—	—	0.3	V
Base-Emitter Voltage	V_{BE}	$V_{CE}=6V, I_C=2mA$	—	0.65	—	V
Transition Frequency	f_T	$V_{CE}=6V, I_C=1mA$	—	100	—	MHz
Collector Output Capacitance	C_{ob}	$V_{CB}=10V, I_E=0, f=1MHz$	—	3.0	—	pF
Noise Figure	NF	$V_{CE}=6V, I_C=100\mu A, f=10Hz, R_g=10k\Omega$	—	—	6	dB
		$V_{CE}=6V, I_C=100\mu A, f=1kHz, R_g=10K\Omega$	—	—	2	
		$V_{CE}=6V, I_C=100\mu A, f=1kHz, R_g=100\Omega$	—	4	—	

NOTE: According to h_{FE} , Classified as follows.

GR	200-400	BL	350-700
----	---------	----	---------

