

2SC3201 供应商
捷多邦, 专业PCB打样工厂 24小时加急出货

SILICON NPN TRANSISTOR

EPITAXIAL PLANAR TYPE (PCT PROCESS)

2SC3201

APPLICATION

- Audio Amplifier Applications.

FEATURES

- High Breakdown Voltage : $V_{CEO}=120V$ (Min.)
- High DC Current Gain : $h_{FE}=200\sim700$.
- Excellent h_{FE} Linearity : $h_{FE}(0.1mA)/h_{FE}(2mA)=0.95$ (Typ.)
- Low Noise : $NF=1dB$ (Typ.), $10dB$ (Max.)
- Complementary to 2SA1269.
- Small Package.

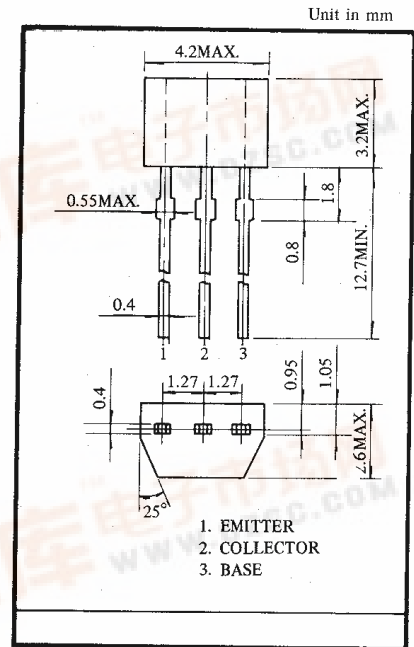

MAXIMUM RATINGS (Ta=25°C)

CHARACTERISTIC	SYMBOL	RATING	UNIT
Collector-Base Voltage	V_{CBO}	120	V
Collector-Emitter Voltage	V_{CEO}	120	V
Emitter-Base Voltage	V_{EBO}	5	V
Collector Current	I_C	100	mA

CHARACTERISTIC	SYMBOL	RATING	UNIT
Emitter Current	I_E	-100	mA
Collector-Power Dissipation	P_C	200	mW
Junction Temperature	T_j	125	°C
Storage Temperature Range	T_{stg}	-55~125	°C

ELECTRICAL CHARACTERISTICS (Ta=25°C)

CHARACTERISTIC	SYMBOL	TEST CONDITION	MIN.	TYP.	MAX.	UNIT
Collector Cut-off Current	I_{CBO}	$V_{CB}=120V, I_E=0$	—	—	0.1	μA
Emitter Cut-off Current	I_{EBO}	$V_{EB}=5V, I_C=0$	—	—	0.1	μA
DC Current Gain	$h_{FE(Notes)}$	$V_{CE}=6V, I_C=2mA$	200	—	700	
Collector-Emitter Saturation Voltage	$V_{CE(sat)}$	$I_C=10mA, I_B=1mA$	—	—	0.3	V
Transition Frequency	f_T	$V_{CE}=6V, I_C=1mA$	—	100	—	MHz
Collector Output Capacitance	C_{ob}	$V_{CB}=10V, I_E=0, f=1MHz$	—	3.0	—	pF
Noise Figure	NF	$V_{CE}=6V, I_C=0.1mA$ $f=1kHz, R_g=10k\Omega$	—	1.0	10	dB

NOTE: According to h_{FE} , Classified as follows.

200~400

BL

350~700

