

TOSHIBA

2SC3302

TOSHIBA TRANSISTOR
SILICON NPN EPITAXIAL PLANAR TYPE
VHF-UHF BAND LOW NOISE AMPLIFIER APPLICATIONS

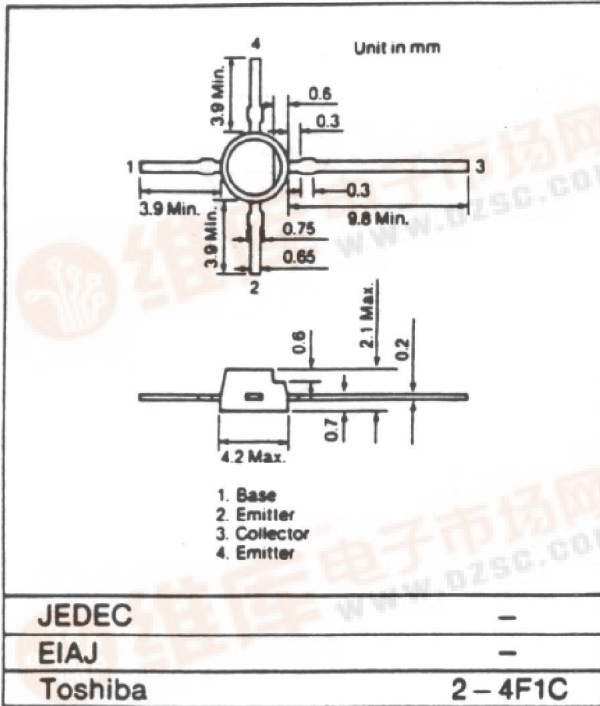

Features:

- NF = 1.5 dB, $S_{21e}^2 = 16.5$ dB ($f = 500$ MHz)
- NF = 1.7 dB, $S_{21e}^2 = 11$ dB ($f = 1000$ MHz)

Maximum Ratings ($T_a = 25^\circ\text{C}$)

Characteristic	Symbol	Rating	Unit
Collector-Base Voltage	V_{CBO}	17	V
Collector-Emitter Voltage	V_{CEO}	12	V
Emitter-Base Voltage	V_{EBO}	3	V
Base Current	I_B	30	mA
Collector Current	I_C	70	mA
Collector Power Dissipation	P_C	200	mW
Junction Temperature	T_J	125	$^\circ\text{C}$
Storage Temperature Range	T_{stg}	-55~125	$^\circ\text{C}$

Marking: ME Weight: 0.08 g

Microwave Characteristics ($T_a = 25^\circ\text{C}$)

Characteristic	Symbol	Test Condition	Min	Typ	Max	Unit
Transition Frequency	f_T	$V_{CE} = 10V, I_C = 20$ mA	-	5	-	GHz
Insertion Gain	$S_{21e}^2(1)$	$V_{CE} = 10V, I_C = 20$ mA, $f = 500$ GHz	-	16.5	-	dB
	$S_{21e}^2(2)$	$V_{CE} = 10V, I_C = 20$ mA, $f = 1$ GHz	-	11	-	dB
Noise Figure	NF (1)	$V_{CE} = 10V, I_C = 5$ mA, $f = 500$ MHz	-	1.5	-	dB
	NF (2)	$V_{CE} = 10V, I_C = 5$ mA, $f = 1$ GHz	-	1.7	-	dB

Electrical Characteristics ($T_a = 25^\circ\text{C}$)

Characteristic	Symbol	Test Condition	Min	Typ	Max	Unit
Collector Cut-off Current	I_{CBO}	$V_{CB} = 10V, I_E = 0$	-	-	1	μA
Emitter Cut-off Current	I_{EBO}	$V_{EB} = 1V, I_C = 0$	-	-	1	μA
DC Current Gain	h_{FE}	$V_{CE} = 10V, I_C = 20$ mA	25	-	-	
Output Capacitance	C_{ob}	$V_{CB} = 10V, I_C = 0, f = 1$ MHz $C_{ex} + C_{CB} + C_{CE}$	-	0.8	-	pF
Reverse Transfer Capacitance	C_{re}	(Note) C_{μ}	-	0.45	-	pF



is measured by 3 terminal method with Capacitance Bridge.

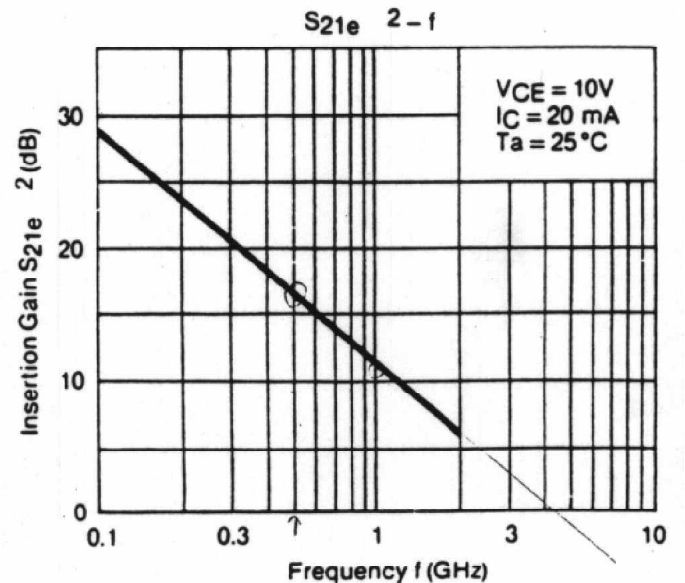
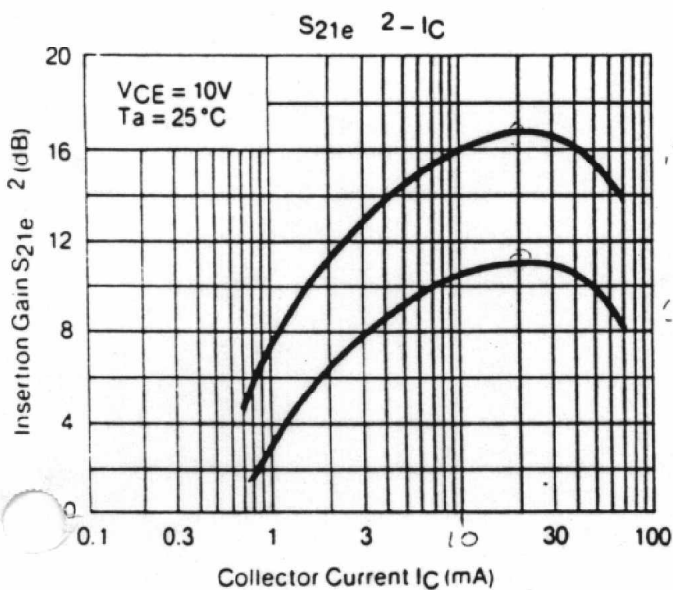
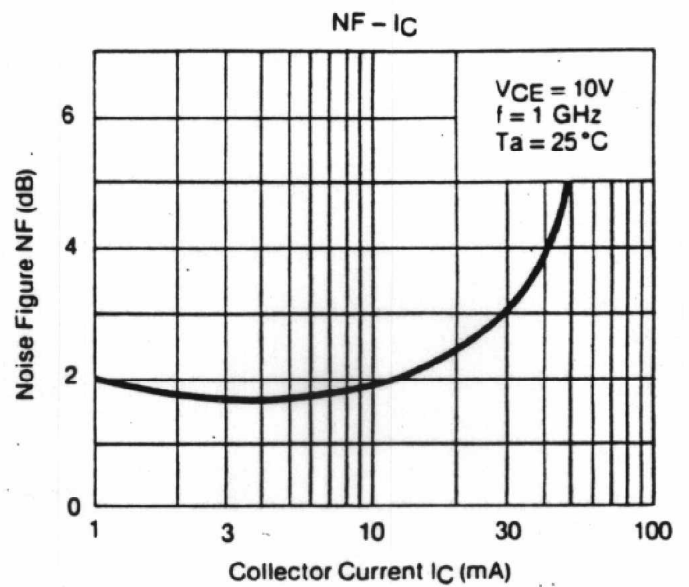
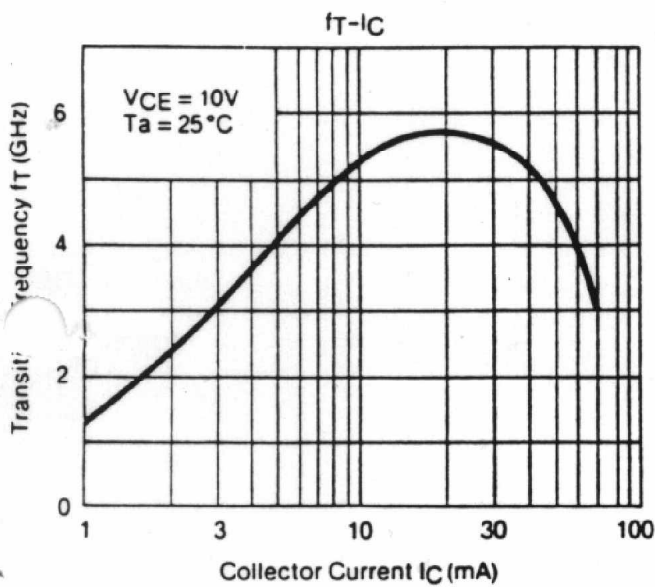
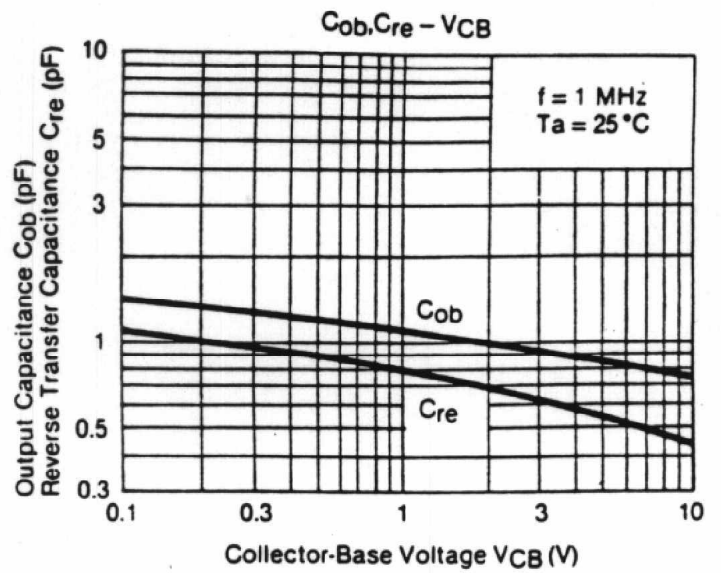
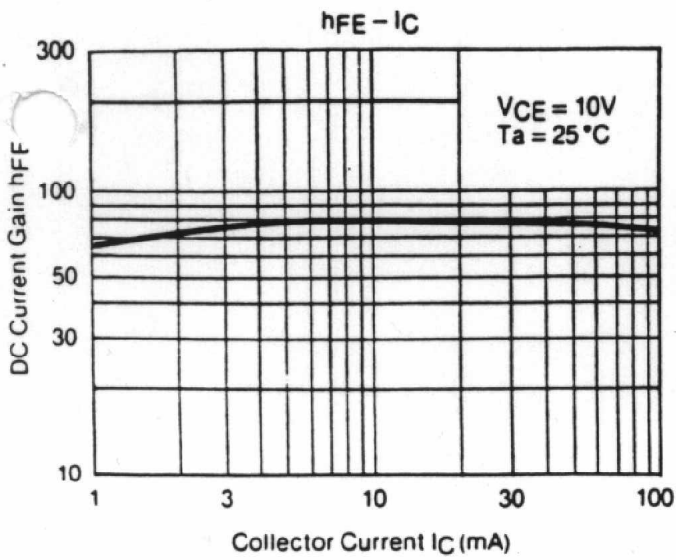

VCE = 10V
 IC = 20 mA
 Ta = 25 °C

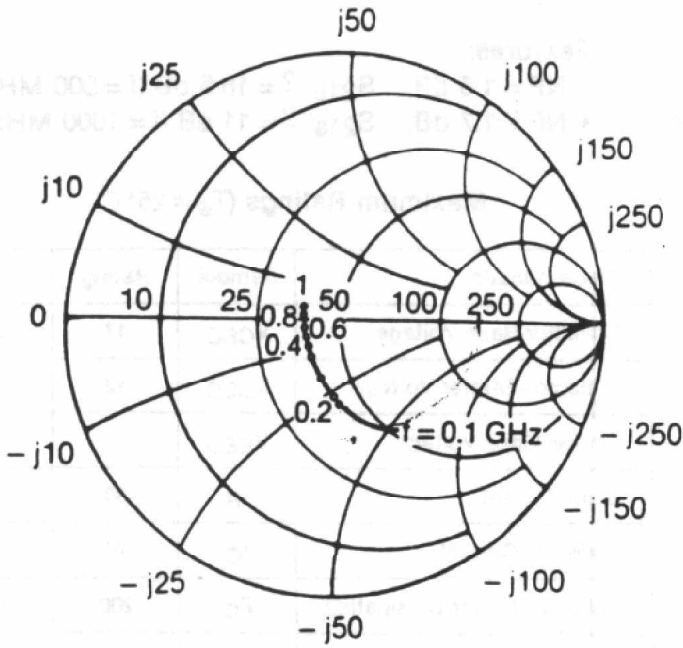

S11e
 (Unit: Ω)

VCE = 10V
 IC = 20 mA
 Ta = 25 °C

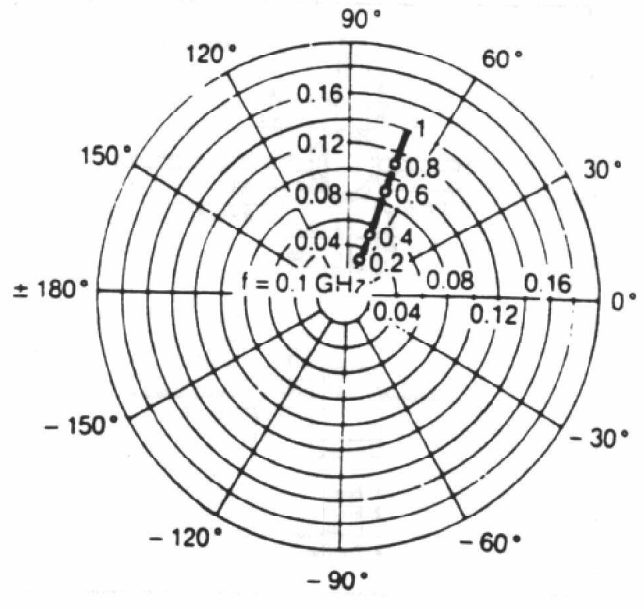

S12e

VCE = 10V
 IC = 20 mA
 Ta = 25 °C

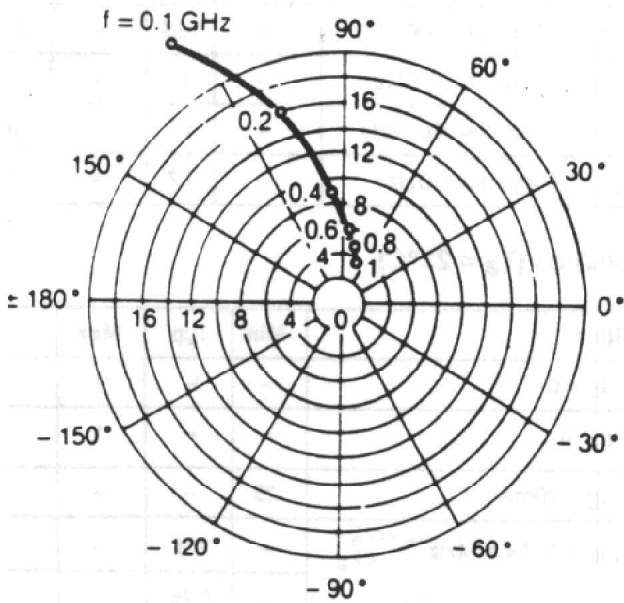

S21e

VCE = 10V
 IC = 20 mA
 Ta = 25 °C

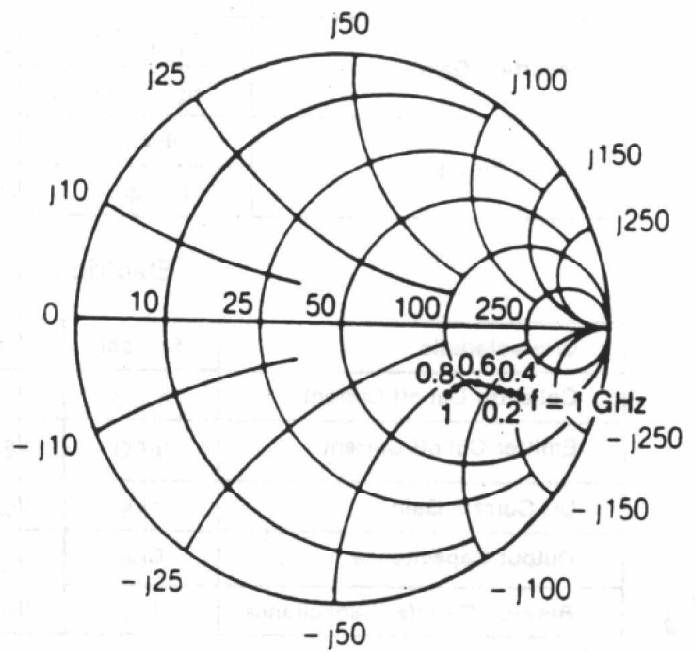

S22e
 (Unit: Ω)