

- **Qualification in Accordance With AEC-Q100†**
- **Qualified for Automotive Applications**
- **Customer-Specific Configuration Control Can Be Supported Along With Major-Change Approval**
- **ESD Protection <500 V Per MIL-STD-883, Method 3015; Exceeds 200 V Using Machine Model (C = 200 pF, R = 0); 1500 V Using Charged Device Model**
- **ESD Human Body Model >2 kV Machine Model >200 V and Charge Device Model = 2 kV For K-Suffix Devices.**
- **Low Supply-Current Drain Independent of Supply Voltage . . . 0.8 mA Typ**
- **Low Input Bias and Offset Parameters:**
 - **Input Offset Voltage . . . 3 mV Typ**
 - **Input Offset Current . . . 2 nA Typ**
 - **Input Bias Current . . . 20 nA Typ**
- **Common-Mode Input Voltage Range Includes Ground, Allowing Direct Sensing Near Ground**
- **Differential Input Voltage Range Equal to Maximum-Rated Supply Voltage:**
 - **Non-V devices . . . 26 V**
 - **V-Suffix devices . . . 32 V**
- **Open-Loop Differential Voltage Amplification . . . 100 V/mV Typ**
- **Internal Frequency Compensation**

D OR PW PACKAGE
(TOP VIEW)

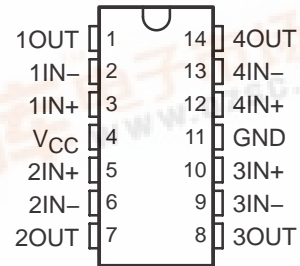

† Contact factory for details. Q100 qualification data available on request.

description/ordering information

This device consists of four independent high-gain frequency-compensated operational amplifiers that are designed specifically to operate from a single supply over a wide range of voltages. Operation from split supplies is possible when the difference between the two supplies is 3 V to 26 V (3 V to 32 V for V-suffixed devices), and V_{CC} is at least 1.5 V more positive than the input common-mode voltage. The low supply-current drain is independent of the magnitude of the supply voltage.

Applications include transducer amplifiers, dc amplification blocks, and all the conventional operational-amplifier circuits that now can be more easily implemented in single-supply-voltage systems. For example, the LM2902 can be operated directly from the standard 5-V supply that is used in digital systems and easily provides the required interface electronics without requiring additional ± 15 -V supplies.

ORDERING INFORMATION

TA	V _{IO} max AT 25°C	MAX V _{CC}	PACKAGE‡		ORDERABLE PART NUMBER	TOP-SIDE MARKING
–40°C to 125°C	7 mV	26 V	SOIC (D)	Reel of 2500	LM2902QDRQ1	2902Q1
			TSSOP (PW)	Reel of 2000	LM2902QPWRQ1	2902Q1
	7 mV	32 V	SOIC (D)	Reel of 2500	LM2902KVQDRQ1	2902KVQ
			TSSOP (PW)	Reel of 2000	LM2902KVQPWRQ1	2902KVQ
	2 mV	32 V	SOIC (D)	Reel of 2500	LM2902KAVQDRQ1	2902KAQ
			TSSOP (PW)	Reel of 2000	LM2902KAVQPWRQ1	2902KAQ

‡ Package drawings, standard packing quantities, thermal data, symbolization, and PCB design guidelines are available at www.ti.com/sc/package.

Please be aware that an important notice concerning availability, standard warranty, and use in critical applications of Texas Instruments semiconductor products and disclaimers thereto appears at the end of this data sheet.



LM2902-Q1 QUADRUPLE OPERATIONAL AMPLIFIER

SGLS178D – AUGUST 2003 – REVISED DECEMBER 2004

symbol (each amplifier)

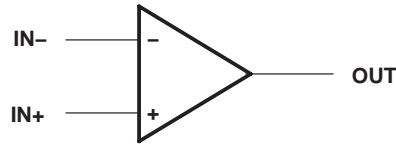

schematic (each amplifier)

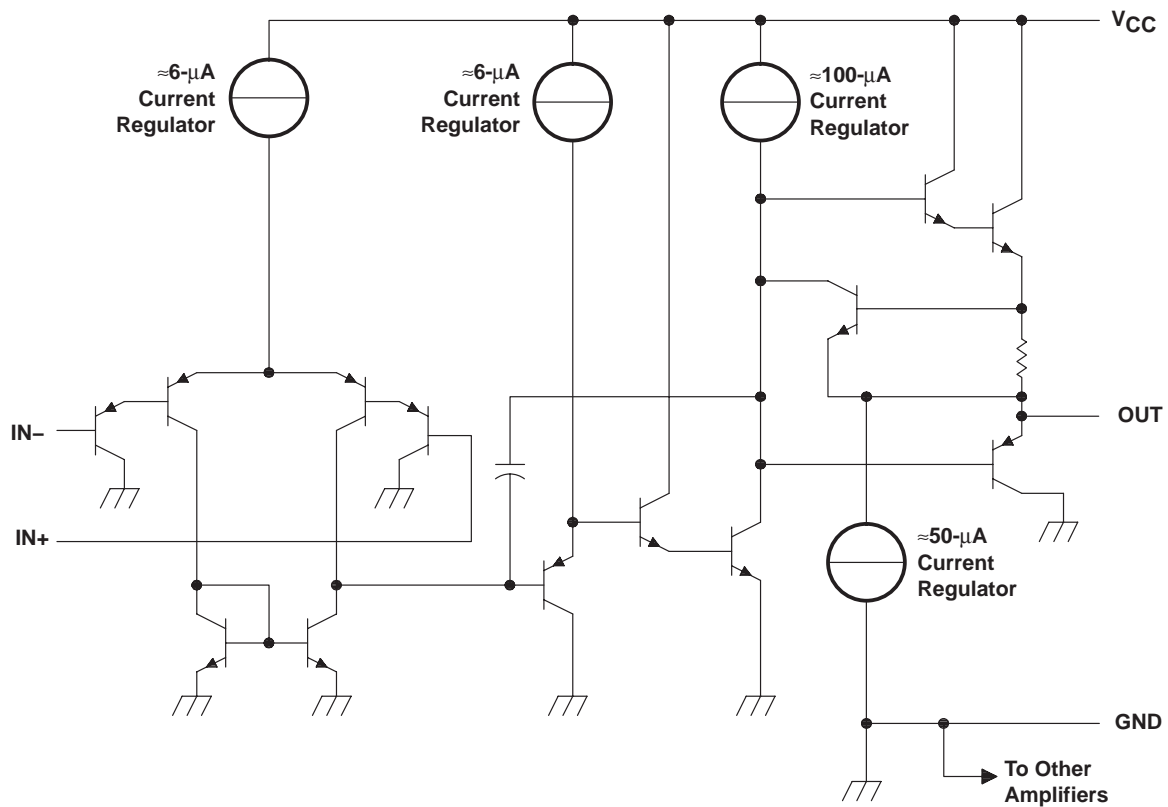

COMPONENT COUNT (TOTAL DEVICE)	
Epi-FET	1
Transistors	95
Diodes	4
Resistors	11
Capacitors	4

LM2902-Q1 QUADRUPLE OPERATIONAL AMPLIFIER

SGLS178D – AUGUST 2003 – REVISED DECEMBER 2004

absolute maximum ratings over operating free-air temperature range (unless otherwise noted)[†]

	LM2902-Q1	LM2902KV-Q1	UNIT
Supply voltage, V_{CC} (see Note 1)	26	32	V
Differential input voltage, V_{ID} (see Note 2)	± 26	± 32	V
Input voltage, V_I (either input)	-0.3 to 26	-0.3 to 32	V
Duration of output short circuit (one amplifier) to ground at (or below) $T_A = 25^\circ\text{C}$, $V_{CC} \leq 15\text{ V}$ (see Note 3)	Unlimited	Unlimited	
Package thermal impedance, θ_{JA} (see Notes 4 and 5)	D package (0 LFPM)	101	$^\circ\text{C}/\text{W}$
	PW package	113	
Operating virtual junction temperature, T_J	142	142	$^\circ\text{C}$
Storage temperature range, T_{stg}	-65 to 150	-65 to 150	$^\circ\text{C}$

[†] Stresses beyond those listed under "absolute maximum ratings" may cause permanent damage to the device. These are stress ratings only, and functional operation of the device at these or any other conditions beyond those indicated under "recommended operating conditions" is not implied. Exposure to absolute-maximum-rated conditions for extended periods may affect device reliability.

- NOTES:
1. All voltage values, except differential voltages and V_{CC} specified for the measurement of I_{OS} , are with respect to the network GND.
 2. Differential voltages are at $IN+$ with respect to $IN-$.
 3. Short circuits from outputs to V_{CC} can cause excessive heating and eventual destruction.
 4. Maximum power dissipation is a function of $T_{J(max)}$, θ_{JA} , and T_A . The maximum allowable power dissipation at any allowable ambient temperature is $P_D = (T_{J(max)} - T_A)/\theta_{JA}$. Operating at the absolute maximum T_J of 142°C can affect reliability.
 5. The package thermal impedance is calculated in accordance with JESD 51-7.

LM2902-Q1

QUADRUPLE OPERATIONAL AMPLIFIER

SGLS178D – AUGUST 2003 – REVISED DECEMBER 2004

electrical characteristics at specified free-air temperature, $V_{CC} = 5\text{ V}$ (unless otherwise noted)

PARAMETER	TEST CONDITIONS†	T_A ‡	LM2902-Q1			UNIT
			MIN	TYP§	MAX	
V_{IO} Input offset voltage	$V_{CC} = 5\text{ V to } 26\text{ V}$, $V_{IC} = V_{ICRmin}$, $V_O = 1.4\text{ V}$	25°C		3	7	mV
		Full range			10	
I_{IO} Input offset current	$V_O = 1.4\text{ V}$	25°C		2	50	nA
		Full range			300	
I_{IB} Input bias current	$V_O = 1.4\text{ V}$	25°C		-20	-250	nA
		Full range			-500	
V_{ICR} Common-mode input voltage range	$V_{CC} = 5\text{ V to } 26\text{ V}$	25°C		0 to $V_{CC} - 1.5$		V
		Full range		0 to $V_{CC} - 2$		
V_{OH} High-level output voltage	$R_L = 10\text{ k}\Omega$	25°C		$V_{CC} - 1.5$		V
	$V_{CC} = 26\text{ V}$, $R_L = 2\text{ k}\Omega$	Full range		22		
	$V_{CC} = 26\text{ V}$, $R_L \geq 10\text{ k}\Omega$	Full range		23	24	
V_{OL} Low-level output voltage	$R_L \leq 10\text{ k}\Omega$	Full range		5	20	mV
A_{VD} Large-signal differential voltage amplification	$V_{CC} = 15\text{ V}$, $V_O = 1\text{ V to } 11\text{ V}$, $R_L \geq 2\text{ k}\Omega$	25°C		100		V/mV
		Full range		15		
CMRR Common-mode rejection ratio	$V_{IC} = V_{ICRmin}$	25°C		50	80	dB
k_{SVR} Supply-voltage rejection ratio ($\Delta V_{CC}/\Delta V_{IO}$)		25°C		50	100	dB
V_{O1}/V_{O2} Crosstalk attenuation	$f = 1\text{ kHz to } 20\text{ kHz}$	25°C		120		dB
I_O Output current	$V_{CC} = 15\text{ V}$, $V_{ID} = 1\text{ V}$, $V_O = 0$	25°C		-20	-30	mA
		Full range		-10		
	$V_{CC} = 15\text{ V}$, $V_{ID} = -1\text{ V}$, $V_O = 15\text{ V}$	25°C		10	20	mA
		Full range		5		
	$V_{ID} = -1\text{ V}$, $V_O = 200\text{ mV}$	25°C		30		μA
I_{OS} Short-circuit output current	V_{CC} at 5 V, $V_O = 0$, GND at -5 V	25°C		± 40	± 60	mA
I_{CC} Supply current (four amplifiers)	$V_O = 2.5\text{ V}$, No load	Full range		0.7	1.2	mA
	$V_{CC} = 26\text{ V}$, $V_O = 0.5 V_{CC}$, No load	Full range		1.4	3	

† All characteristics are measured under open-loop conditions, with zero common-mode input voltage, unless otherwise specified.

‡ Full range is -40°C to 125°C.

§ All typical values are at $T_A = 25^\circ\text{C}$.

LM2902-Q1 QUADRUPLE OPERATIONAL AMPLIFIER

SGLS178D – AUGUST 2003 – REVISED DECEMBER 2004

electrical characteristics at specified free-air temperature, $V_{CC} = 5\text{ V}$ (unless otherwise noted) (continued)

PARAMETER	TEST CONDITIONS†	T_A ‡	LM2902KV-Q1			UNIT	
			MIN	TYP§	MAX		
V_{IO} Input offset voltage	$V_{CC} = 5\text{ V to }32\text{ V}$, $V_{IC} = V_{ICRmin}$, $V_O = 1.4\text{ V}$	Non-A devices	25°C	3	7	mV	
			Full range		10		
		A-suffix devices	25°C	1	2		
			Full range		4		
$\Delta V_{IO}/\Delta T$ Temperature drift	$R_S = 0\ \Omega$	Full range	7		$\mu\text{V}/^\circ\text{C}$		
I_{IO} Input offset current	$V_O = 1.4\text{ V}$	25°C	2	50	nA		
		Full range		150			
$\Delta I_{IO}/\Delta T$ Temperature drift		Full range	10		$\text{pA}/^\circ\text{C}$		
I_{IB} Input bias current	$V_O = 1.4\text{ V}$	25°C	-20	-250	nA		
		Full range		-500			
V_{ICR} Common-mode input voltage range	$V_{CC} = 5\text{ V to }32\text{ V}$	25°C	0 to $V_{CC} - 1.5$		V		
		Full range	0 to $V_{CC} - 2$				
V_{OH} High-level output voltage	$R_L = 10\text{ k}\Omega$	25°C	$V_{CC} - 1.5$		V		
	$V_{CC} = 32\text{ V}$, $R_L = 2\text{ k}\Omega$	Full range	26				
	$V_{CC} = 32\text{ V}$, $R_L \geq 10\text{ k}\Omega$	Full range	27				
V_{OL} Low-level output voltage	$R_L \leq 10\text{ k}\Omega$	Full range	5	20	mV		
A_{VD} Large-signal differential voltage amplification	$V_{CC} = 15\text{ V}$, $V_O = 1\text{ V to }11\text{ V}$, $R_L \geq 2\text{ k}\Omega$	25°C	25	100	V/mV		
		Full range	15				
Amplifier-to-amplifier coupling¶	$f = 1\text{ kHz to }20\text{ kHz}$, input referred	25°C	120		dB		
CMRR Common-mode rejection ratio	$V_{IC} = V_{ICRmin}$	25°C	60	80	dB		
k_{SVR} Supply-voltage rejection ratio ($\Delta V_{CC}/\Delta V_{IO}$)		25°C	60	100	dB		
V_{O1}/V_{O2} Crosstalk attenuation	$f = 1\text{ kHz to }20\text{ kHz}$	25°C	120		dB		
I_O Output current	$V_{CC} = 15\text{ V}$, $V_O = 0$	$V_{ID} = 1\text{ V}$	25°C	-20	-30	-60	mA
		Full range		-10			
	$V_{CC} = 15\text{ V}$, $V_O = 15\text{ V}$	$V_{ID} = -1\text{ V}$	25°C	10	20		
		Full range		5			
	$V_{ID} = -1\text{ V}$, $V_O = 200\text{ mV}$	25°C	12	40		μA	
I_{OS} Short-circuit output current	V_{CC} at 5 V, GND at -5 V	$V_O = 0$	25°C	± 40	± 60	mA	
I_{CC} Supply current (four amplifiers)	$V_O = 2.5\text{ V}$, No load	Full range	0.7	1.2	mA		
	$V_{CC} = 32\text{ V}$, $V_O = 0.5 V_{CC}$, No load	Full range	1.4	3			

† All characteristics are measured under open-loop conditions, with zero common-mode input voltage, unless otherwise specified.

‡ Full range is -40°C to 125°C .

§ All typical values are at $T_A = 25^\circ\text{C}$.

¶ Due to proximity of external components, ensure that coupling is not originating via stray capacitance between these external parts. Typically, this can be detected, as this type of coupling increases at higher frequencies.

LM2902-Q1 QUADRUPLE OPERATIONAL AMPLIFIER

SGLS178D – AUGUST 2003 – REVISED DECEMBER 2004

operating conditions, $V_{CC} = \pm 15\text{ V}$, $T_A = 25^\circ\text{C}$

PARAMETER		TEST CONDITIONS	TYP	UNIT
SR	Slew rate at unity gain	$R_L = 1\text{ M}\Omega$, $C_L = 30\text{ pF}$, $V_I = \pm 10\text{ V}$ (see Figure 1)	0.5	$\text{V}/\mu\text{s}$
B_1	Unity-gain bandwidth	$R_L = 1\text{ M}\Omega$, $C_L = 20\text{ pF}$ (see Figure 1)	1.2	MHz
V_n	Equivalent input noise voltage	$R_S = 100\ \Omega$, $V_I = 0\text{ V}$, $f = 1\text{ kHz}$ (see Figure 2)	35	$\text{nV}/\sqrt{\text{Hz}}$

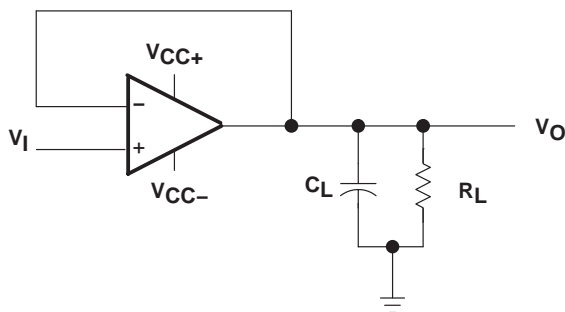

Figure 1. Unity-Gain Amplifier

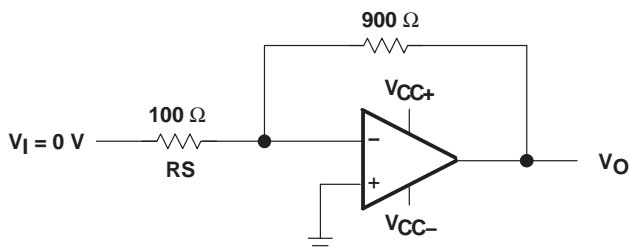

Figure 2. Noise-Test Circuit

PACKAGING INFORMATION

Orderable Device	Status ⁽¹⁾	Package Type	Package Drawing	Pins	Package Qty	Eco Plan ⁽²⁾	Lead/Ball Finish	MSL Peak Temp ⁽³⁾
LM2902KAVQDRQ1	ACTIVE	SOIC	D	14	2500	Pb-Free (RoHS)	CU NIPDAU	Level-2-250C-1 YEAR/ Level-1-235C-UNLIM
LM2902KAVQPWRQ1	ACTIVE	TSSOP	PW	14	2000	TBD	CU NIPDAU	Level-1-250C-UNLIM
LM2902KVQDRQ1	ACTIVE	SOIC	D	14	2500	Pb-Free (RoHS)	CU NIPDAU	Level-2-250C-1 YEAR/ Level-1-235C-UNLIM
LM2902KVQPWRQ1	ACTIVE	TSSOP	PW	14	2000	TBD	CU NIPDAU	Level-1-250C-UNLIM
LM2902QDRQ1	ACTIVE	SOIC	D	14	2500	Pb-Free (RoHS)	CU NIPDAU	Level-2-250C-1 YEAR/ Level-1-235C-UNLIM
LM2902QPWRQ1	ACTIVE	TSSOP	PW	14	2000	TBD	CU NIPDAU	Level-1-250C-UNLIM

⁽¹⁾ The marketing status values are defined as follows:

ACTIVE: Product device recommended for new designs.

LIFEBUY: TI has announced that the device will be discontinued, and a lifetime-buy period is in effect.

NRND: Not recommended for new designs. Device is in production to support existing customers, but TI does not recommend using this part in a new design.

PREVIEW: Device has been announced but is not in production. Samples may or may not be available.

OBSOLETE: TI has discontinued the production of the device.

⁽²⁾ Eco Plan - The planned eco-friendly classification: Pb-Free (RoHS), Pb-Free (RoHS Exempt), or Green (RoHS & no Sb/Br) - please check <http://www.ti.com/productcontent> for the latest availability information and additional product content details.

TBD: The Pb-Free/Green conversion plan has not been defined.

Pb-Free (RoHS): TI's terms "Lead-Free" or "Pb-Free" mean semiconductor products that are compatible with the current RoHS requirements for all 6 substances, including the requirement that lead not exceed 0.1% by weight in homogeneous materials. Where designed to be soldered at high temperatures, TI Pb-Free products are suitable for use in specified lead-free processes.

Pb-Free (RoHS Exempt): This component has a RoHS exemption for either 1) lead-based flip-chip solder bumps used between the die and package, or 2) lead-based die adhesive used between the die and leadframe. The component is otherwise considered Pb-Free (RoHS compatible) as defined above.

Green (RoHS & no Sb/Br): TI defines "Green" to mean Pb-Free (RoHS compatible), and free of Bromine (Br) and Antimony (Sb) based flame retardants (Br or Sb do not exceed 0.1% by weight in homogeneous material)

⁽³⁾ MSL, Peak Temp. -- The Moisture Sensitivity Level rating according to the JEDEC industry standard classifications, and peak solder temperature.

Important Information and Disclaimer:The information provided on this page represents TI's knowledge and belief as of the date that it is provided. TI bases its knowledge and belief on information provided by third parties, and makes no representation or warranty as to the accuracy of such information. Efforts are underway to better integrate information from third parties. TI has taken and continues to take reasonable steps to provide representative and accurate information but may not have conducted destructive testing or chemical analysis on incoming materials and chemicals. TI and TI suppliers consider certain information to be proprietary, and thus CAS numbers and other limited information may not be available for release.

In no event shall TI's liability arising out of such information exceed the total purchase price of the TI part(s) at issue in this document sold by TI to Customer on an annual basis.

D (R-PDSO-G14)

PLASTIC SMALL-OUTLINE PACKAGE

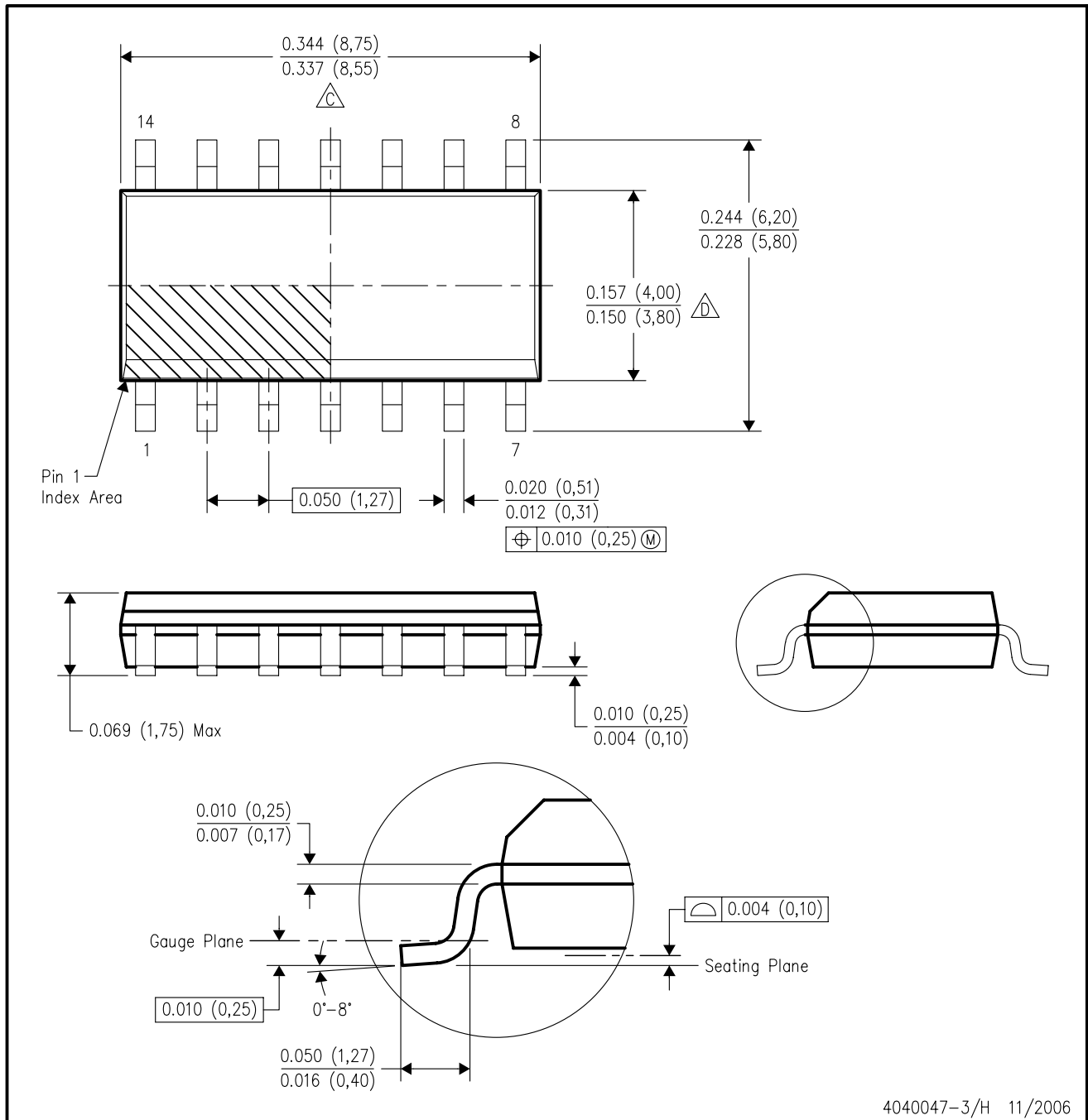

- NOTES:
- A. All linear dimensions are in inches (millimeters).
 - B. This drawing is subject to change without notice.
 - $\triangle C$ Body length does not include mold flash, protrusions, or gate burrs. Mold flash, protrusions, or gate burrs shall not exceed .006 (0,15) per end.
 - $\triangle D$ Body width does not include interlead flash. Interlead flash shall not exceed .017 (0,43) per side.
 - E. Reference JEDEC MS-012 variation AB.

MECHANICAL DATA

MTSS001C – JANUARY 1995 – REVISED FEBRUARY 1999

PW (R-PDSO-G)**

PLASTIC SMALL-OUTLINE PACKAGE

14 PINS SHOWN

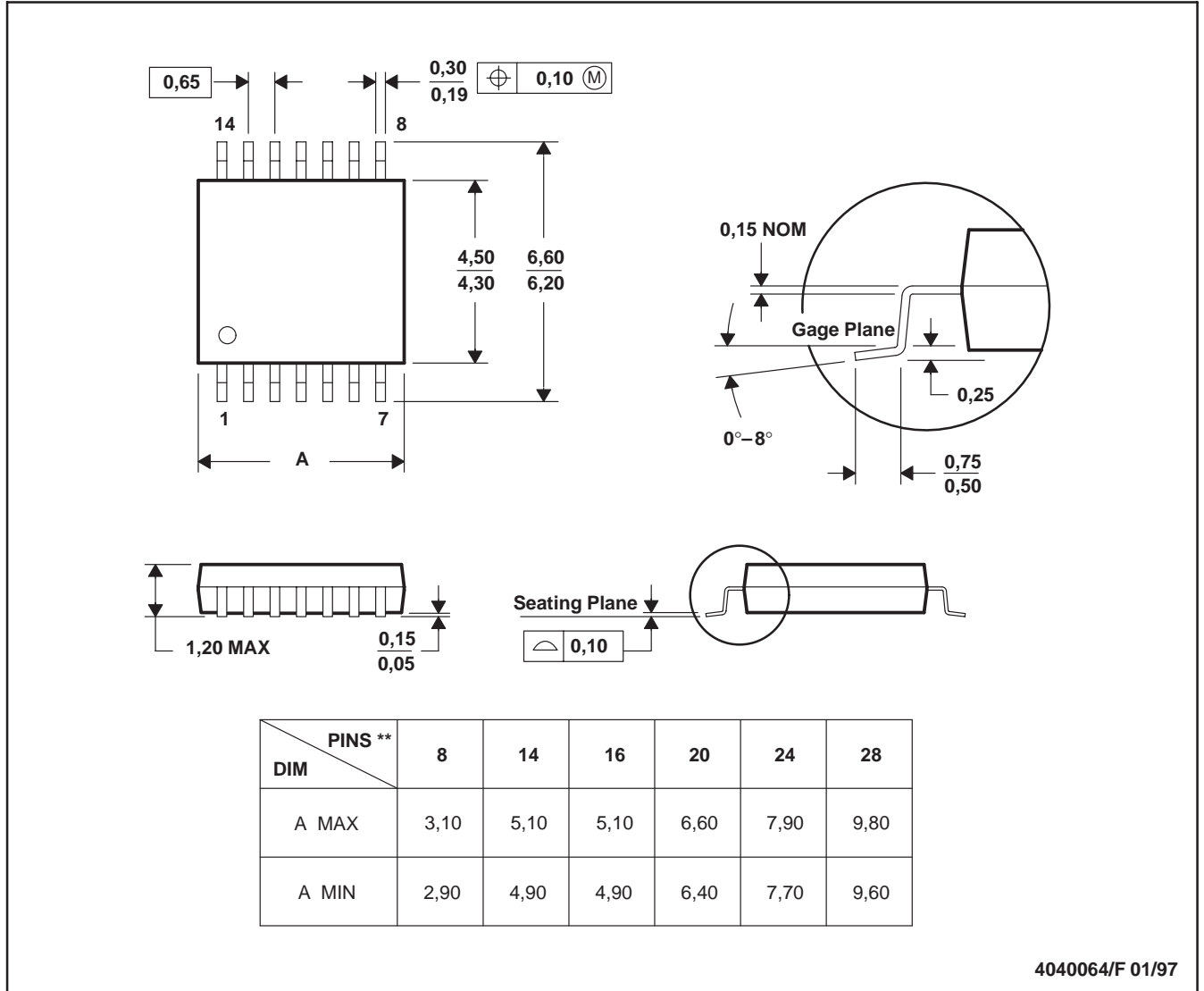

4040064/F 01/97

- NOTES: A. All linear dimensions are in millimeters.
 B. This drawing is subject to change without notice.
 C. Body dimensions do not include mold flash or protrusion not to exceed 0,15.
 D. Falls within JEDEC MO-153

IMPORTANT NOTICE

Texas Instruments Incorporated and its subsidiaries (TI) reserve the right to make corrections, modifications, enhancements, improvements, and other changes to its products and services at any time and to discontinue any product or service without notice. Customers should obtain the latest relevant information before placing orders and should verify that such information is current and complete. All products are sold subject to TI's terms and conditions of sale supplied at the time of order acknowledgment.

TI warrants performance of its hardware products to the specifications applicable at the time of sale in accordance with TI's standard warranty. Testing and other quality control techniques are used to the extent TI deems necessary to support this warranty. Except where mandated by government requirements, testing of all parameters of each product is not necessarily performed.

TI assumes no liability for applications assistance or customer product design. Customers are responsible for their products and applications using TI components. To minimize the risks associated with customer products and applications, customers should provide adequate design and operating safeguards.

TI does not warrant or represent that any license, either express or implied, is granted under any TI patent right, copyright, mask work right, or other TI intellectual property right relating to any combination, machine, or process in which TI products or services are used. Information published by TI regarding third-party products or services does not constitute a license from TI to use such products or services or a warranty or endorsement thereof. Use of such information may require a license from a third party under the patents or other intellectual property of the third party, or a license from TI under the patents or other intellectual property of TI.

Reproduction of information in TI data books or data sheets is permissible only if reproduction is without alteration and is accompanied by all associated warranties, conditions, limitations, and notices. Reproduction of this information with alteration is an unfair and deceptive business practice. TI is not responsible or liable for such altered documentation.

Resale of TI products or services with statements different from or beyond the parameters stated by TI for that product or service voids all express and any implied warranties for the associated TI product or service and is an unfair and deceptive business practice. TI is not responsible or liable for any such statements.

TI products are not authorized for use in safety-critical applications (such as life support) where a failure of the TI product would reasonably be expected to cause severe personal injury or death, unless officers of the parties have executed an agreement specifically governing such use. Buyers represent that they have all necessary expertise in the safety and regulatory ramifications of their applications, and acknowledge and agree that they are solely responsible for all legal, regulatory and safety-related requirements concerning their products and any use of TI products in such safety-critical applications, notwithstanding any applications-related information or support that may be provided by TI. Further, Buyers must fully indemnify TI and its representatives against any damages arising out of the use of TI products in such safety-critical applications.

TI products are neither designed nor intended for use in military/aerospace applications or environments unless the TI products are specifically designated by TI as military-grade or "enhanced plastic." Only products designated by TI as military-grade meet military specifications. Buyers acknowledge and agree that any such use of TI products which TI has not designated as military-grade is solely at the Buyer's risk, and that they are solely responsible for compliance with all legal and regulatory requirements in connection with such use.

TI products are neither designed nor intended for use in automotive applications or environments unless the specific TI products are designated by TI as compliant with ISO/TS 16949 requirements. Buyers acknowledge and agree that, if they use any non-designated products in automotive applications, TI will not be responsible for any failure to meet such requirements.

Following are URLs where you can obtain information on other Texas Instruments products and application solutions:

Products		Applications	
Amplifiers	amplifier.ti.com	Audio	www.ti.com/audio
Data Converters	dataconverter.ti.com	Automotive	www.ti.com/automotive
DSP	dsp.ti.com	Broadband	www.ti.com/broadband
Interface	interface.ti.com	Digital Control	www.ti.com/digitalcontrol
Logic	logic.ti.com	Military	www.ti.com/military
Power Mgmt	power.ti.com	Optical Networking	www.ti.com/opticalnetwork
Microcontrollers	microcontroller.ti.com	Security	www.ti.com/security
RFID	www.ti-rfid.com	Telephony	www.ti.com/telephony
Low Power Wireless	www.ti.com/lpw	Video & Imaging	www.ti.com/video
		Wireless	www.ti.com/wireless