

UTC 31002A LINEAR INTEGRATED CIRCUIT

TELEPHONE TONE RINGER

DESCRIPTION

The UTC 31002A is a bipolar integrated circuit designed for telephone bell replacement. It can also be used as alarms or other alerting devices.

FEATURES

- *Designed for telephone bell replacement.
- *Low current drain for multiple extension of lines.
- *Adjustable 2-frequency tone.
- *Adjustable warbling rate.
- *Built-in hysteresis prevents false triggering and rotary dial 'CHIRPS'.
- *Programmable for initiation current by simple external resistor

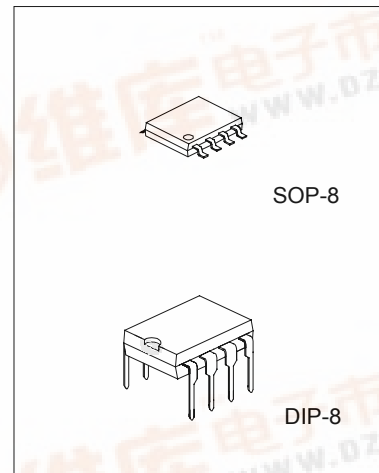

PIN CONFIGURATIONS

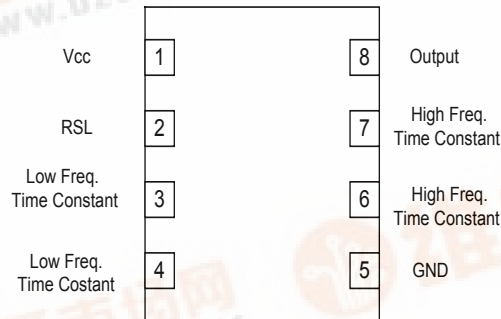

ABSOLUTE MAXIMUM RATINGS(Ta=25°C)

PARAMETER	SYMBOL	VALUE	UNIT
Supply Voltage	Vcc	30	V
Power Dissipation	Pd	400	mW
Operating Temperature	Topr	-45 to 85	°C
Storage Temperature	Tstg	-65 to 150	°C



UTC 31002A LINEAR INTEGRATED CIRCUIT

BLOCK DIAGRAM

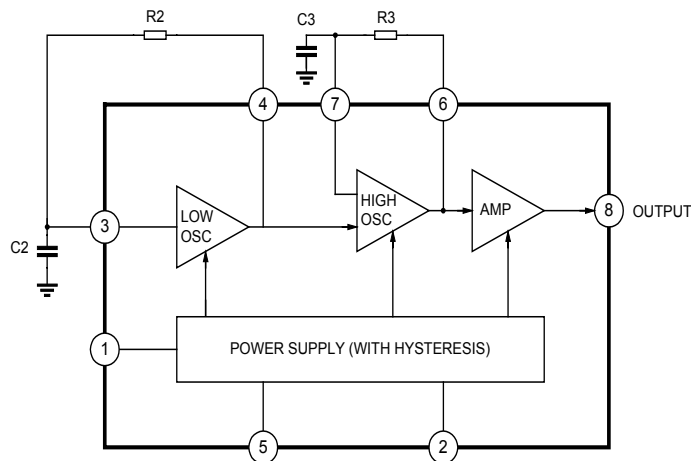

Note: R2, R3, C2 and C3 are parts externally mounted

ELECTRICAL CHARACTERISTICS (Ta=25°C, all voltage referenced to GND unless otherwise specified)

PARAMETER	SYMBOL	TEST CONDITIONS	MIN	TYP	MAX	UNIT
Operating Supply Voltage	V _{cc}				29.0	V
Initiation Supply Voltage (note 1)	V _{si}	See Fig.2	17	19	21	V
Initiation Supply Current (note 1)	I _{si}	6.8K-Pin 2 to GND	1.4	2.8	4.2	mA
Sustaining Voltage (note 2)	V _{sus}	See Fig.2	9.7	11.0	12.0	V
Sustaining Current (note 2)	I _{sus}	No Load V _{cc} =V _{sus} , See Fig.2	0.7	1.4	2.5	mA
Output Voltage High	VOH	V _{cc} =21V, I ₈ =-15mA Pin6=6V, Pin7=GND	17.0	19.0	21.0	V
Output Voltage Low	VOL	V _{cc} =21V, I ₈ =15mA Pin6=GND, Pin7=6V			1.6	V
I _{IN} (Pin 3)		Pin3=6V, Pin4=GND			500	nA
I _{IN} (Pin 7)		Pin7=6V, Pin6=GND			500	nA
High Frequency 1	FH1	R3=191K, C3=6800pF	461	512	563	Hz
High Frequency 2	FH2	R3=191K, C3=6800pF	576	640	704	Hz
Low Frequency	FL	R2=165K, C2=0.47μF	9.0	10	11.0	Hz

*NOTE (See electrical characteristics sheet)

1. Initiation supply voltage (V_{si}) is the supply voltage required to start the tone ringer oscillating.
2. Sustaining voltage (V_{sus}) is the supply voltage required to maintain oscillation.

UTC 31002A LINEAR INTEGRATED CIRCUIT

APPLICATION NOTE

The application circuit illustrates the use of the UTC 31002A device in typical telephone tone ringer application.

The AC ringer signal voltage appears across the TIP and RING inputs of the circuit and is attenuated by capacitor C1 and resistor R1.

C1 also provides isolation from DC voltage (48V) on the exchanged line.

After full wave rectification by the bridge diode, the wave form is filtered by capacitor C4 to provide a DC supply for the tone ringer chip.

As this voltage exceeds the initiation voltage (V_{si}), oscillation starts.

With the components shown, the output frequency chops between 512Hz (F_{H1}) and 640 Hz(F_{H2}) at a 10 Hz(F_L) rate.

The loudspeaker load is coupled through a 1300 Ω to 8 Ω transformer.

The output coupling capacitor C5 is required with transformer coupled loads.

When driving a piezo-ceramic transducer type load, the coupling C5 and transformer (1300 Ω :8 Ω) are not required.

However, a current limiting resistor is required.

The low frequency oscillator oscillates at a rate (F_L) controlled by an external resistor (R2) and capacitor (C2).

The frequency can be determined using the relation $F_L = 1/1.289 R_2 \cdot C_2$. The high frequency oscillates at a F_{H1}, F_{H2} controlled by an external resistor (R3) and capacitor (C3). The frequency can be determined using the relation $F_{H1} = 1/1.504 R_3 \cdot C_3$ and $F_{H2} = 1/1.203 R_3 \cdot C_3$.

Pin 2 of the UTC 31002A allows connection of external resistor RSL, which is used to program the slope of the supply current vs. supply voltage characteristics (see Fig.3), and hence the supply current up to the initiation voltage (V_{si}). This initiation voltage remains constant independent of RSL.

The supply current drawn prior to triggering varies inversely with RSL, decreasing for increasing value of resistance. Thus, increasing the value of RSL, will decrease the amount of AC ringing current required to trigger the device. As such, longer subscriber loops are possible since less voltage is dropped per unit length of loop wire due to the lower current level. RSL can also be used to compensate for smaller AC coupling capacitors (C5 on Fig.4) (higher impedance) to the line which can be used to alter the ringer equivalence number of a tone ringer circuit.

The graph in Fig.3 illustrates the variation of supply current with supply voltage of the UTC 31002A. Three curves are drawn to show the variation of initiation current with RSL. Curve B (RSL=6.8K)

shows the I-V characteristic for UTC 31002A tone ringer. Curve A is a plot with $RSL < 6.8K\Omega$ and shows an increase in the current drawn up to the initiation voltage V_{si} . The I-V characteristic after initiation remains unchanged. Curve C illustrates the effect of increasing RSL above 6.8K initiation current decreases but again current after triggering is unchanged.

UTC 31002A LINEAR INTEGRATED CIRCUIT

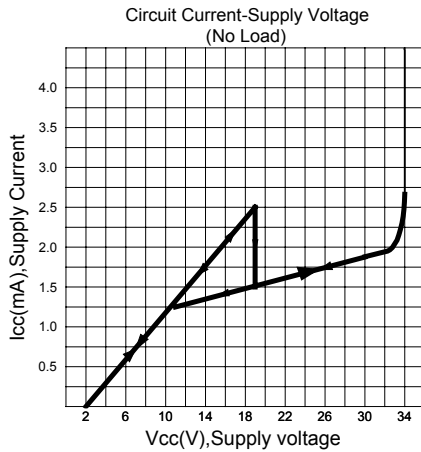

Fig.2

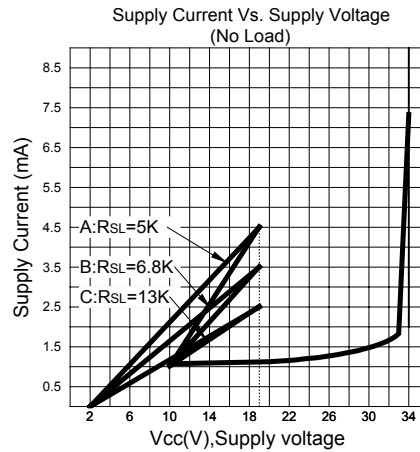

Fig. 3

APPLICATION CIRCUIT

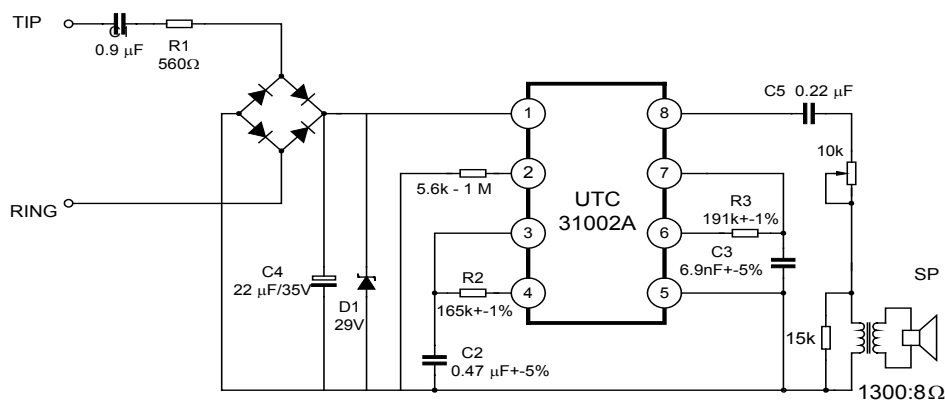

Fig.4

UTC assumes no responsibility for equipment failures that result from using products at values that exceed, even momentarily, rated values (such as maximum ratings, operating condition ranges, or other parameters) listed in products specifications of any and all UTC products described or contained herein. UTC products are not designed for use in life support appliances, devices or systems where malfunction of these products can be reasonably expected to result in personal injury. Reproduction in whole or in part is prohibited without the prior written consent of the copyright owner. The information presented in this document does not form part of any quotation or contract, is believed to be accurate and reliable and may be changed without notice.