



EVERLIGHT ELECTRONICS CO., LTD.

Technical Data Sheet - Preliminary

Luminosity White Color LED

67-235UWC/TR8

Features

- Super luminosity white LED.
- White SMT package.
- Built in 3 LED chips.
- Lead frame package with individual 6 pins.
- Wide viewing angle.
- Soldering methods: Reflow soldering.
- High performance.
- Pb-free.
- The product itself will remain within RoHS compliant version.

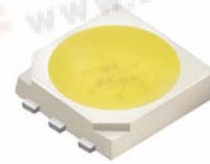

Descriptions

- Due to the package design, 67-235 has wide viewing angle, low power consumption and high luminous intensity. This feature makes it ideal for light pipe or lighting application.

Applications

- Amusement equipment.
- Information boards.
- Flashlight for digital camera of cellular phone.
- Lighting for small size device.

Device Selection Guide

Chip	Emitted Color	Resin Color
Material		
InGaN	White	Water Clear





EVERLIGHT ELECTRONICS CO., LTD.

Technical Data Sheet - Preliminary

Luminosity White Color LED

67-235UWC/TR8

Package Outline Dimensions

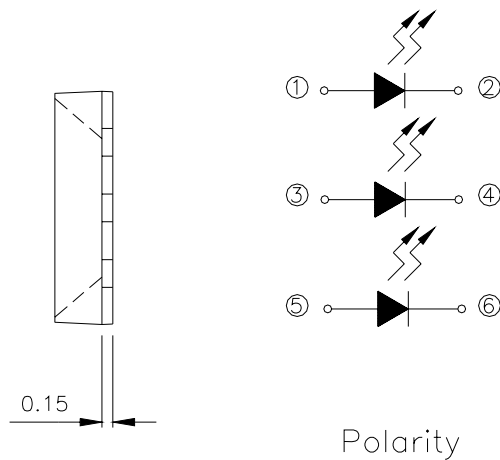
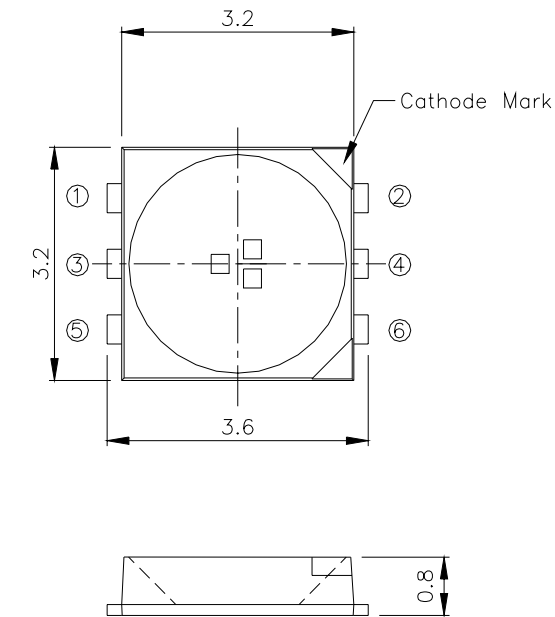

Recommended soldering pad design

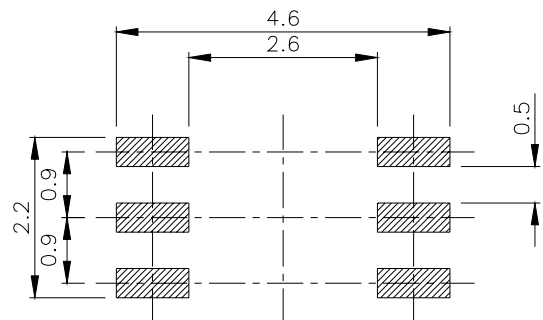
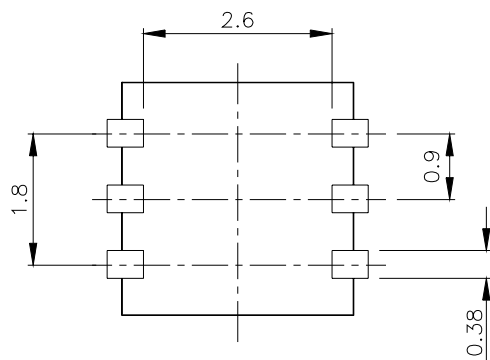

- Notes:** 1.All dimensions are in millimeters.
2.Tolerances unspecified are ± 0.1 mm.



EVERLIGHT ELECTRONICS CO., LTD.

Technical Data Sheet - Preliminary

Luminosity White Color LED

67-235UWC/TR8

Absolute Maximum Ratings (Ta=25°C)

Parameter	Symbol	Rating	Unit
Reverse Voltage*1	V _R	5	V
Peak Forward Current (Duty 1/10 @1KHz) *1	I _{FP}	100	mA
Forward Current*1	I _F	25	mA
Power Dissipation*1	P _d	100	mW
Operating Temperature	T _{opr}	-40 ~ +85	°C
Storage Temperature	T _{stg}	-40 ~ +90	°C
Electrostatic Discharge(HBM) *1	ESD	150	V
Soldering Temperature	T _{sol}	Reflow Soldering : 260 °C for 10 sec. Hand Soldering : 350 °C for 3 sec.	

Notes:

1. The value are based on 1 die performace
2. The products are sensitive to static electricity and care must be fully taken when handling products.



EVERLIGHT ELECTRONICS CO., LTD.

Technical Data Sheet - Preliminary

Luminosity White Color LED

67-235UWC/TR8

Electro-Optical Characteristics (Ta=25°C)

Parameter	Symbol	Min.	Typ.	Max.	Unit	Condition
Luminous Intensity*1	I _V	2000	2500	-----	mcd	I _F =20mA*2
		-----	7000 ^{*3}	-----		I _{FP} =100mA*2 (Duty 1/10 @ 400ms)
Viewing Angle*2	2θ _{1/2}	-----	120	-----	deg	I _F =20mA*2
Forward Voltage*2	V _F	-----	3.5	4.0	V	I _F =20mA*2
		-----	4.3 ^{*3}	-----		I _{FP} =100mA*2 (Duty 1/10 @ 400ms)
Reverse Current*1	I _R	-----	-----	50	μA	V _R =5V

Notes:

1. When three LED dies are operated simultaneously.
2. For each die.
3. The value only for reference.



EVERLIGHT ELECTRONICS CO., LTD.

Technical Data Sheet - Preliminary

Luminosity White Color LED

67-235UWC/TR8

Color Ranks

	Rank A0			
x	0.280	0.264	0.283	0.296
y	0.248	0.267	0.305	0.276

	Rank B2			
x	0.296	0.287	0.330	0.330
y	0.276	0.295	0.339	0.318

	Rank B1			
x	0.287	0.283	0.330	0.330
y	0.295	0.305	0.360	0.339

	Rank C0			
x	0.330	0.330	0.361	0.356
y	0.318	0.360	0.385	0.351

*The C.I.E. 1931 color rank (Tolerance ± 0.01).

CIE Chromaticity Diagram

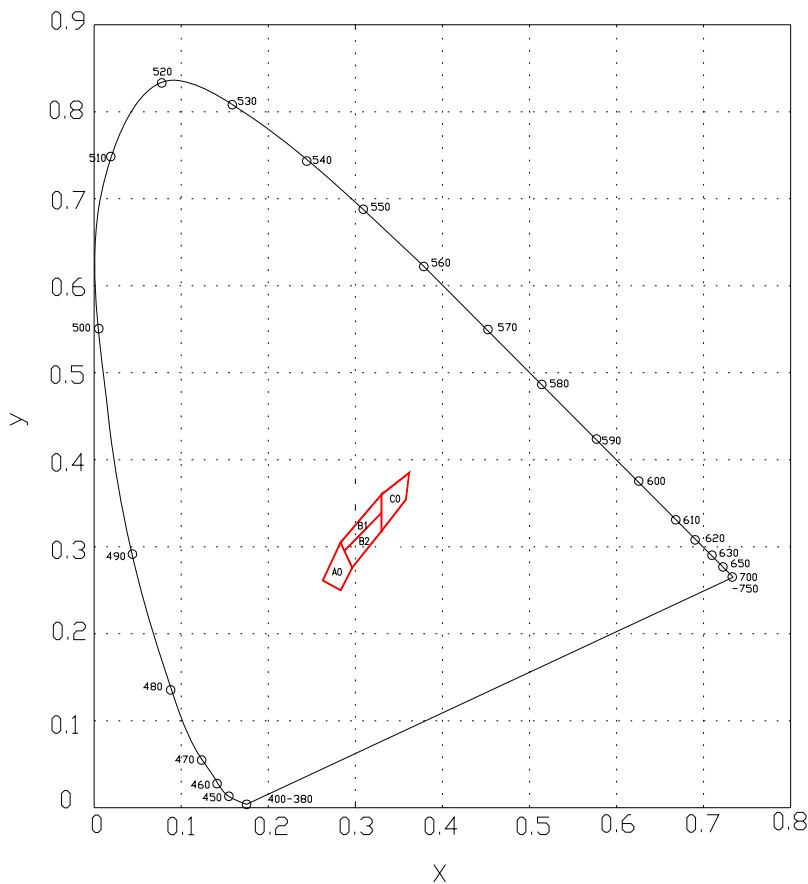



Technical Data Sheet - Preliminary

Luminosity White Color LED

67-235UWC/TR8

Typical Electro-Optical Characteristics Curves

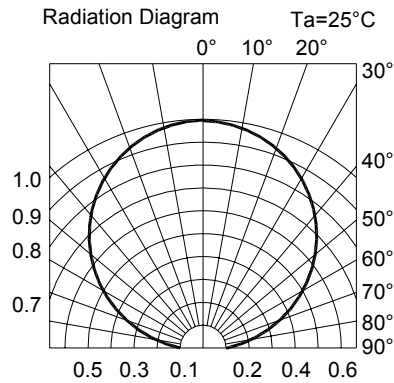
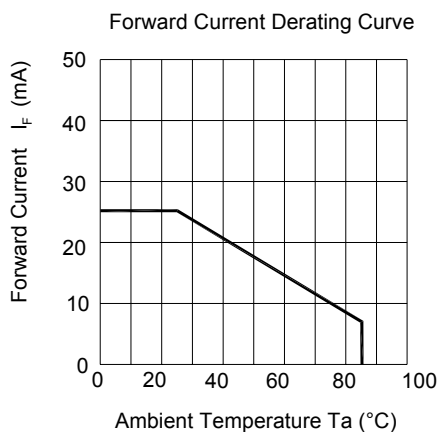
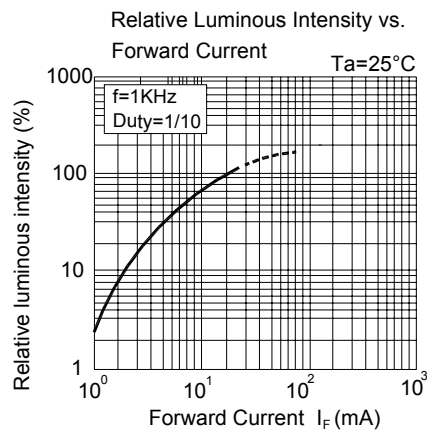
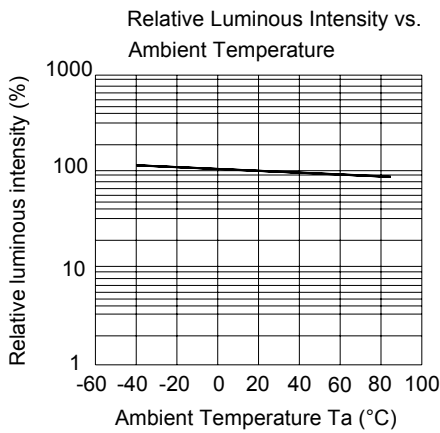
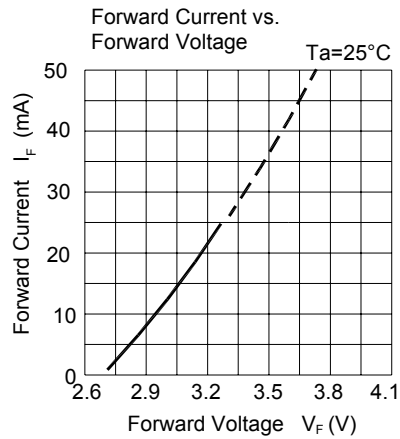
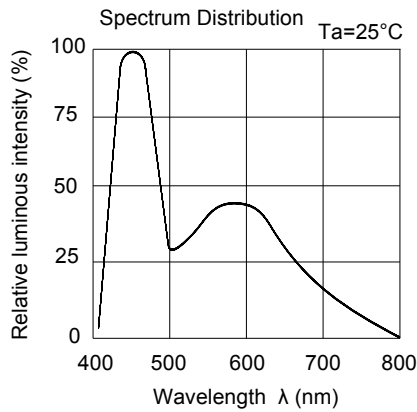



EVERLIGHT ELECTRONICS CO., LTD.

Technical Data Sheet - Preliminary

Luminosity White Color LED

67-235UWC/TR8

Label Explanation

CAT: Luminous Intensity Rank

HUE: Dom. Wavelength Rank

REF: Forward Voltage Rank

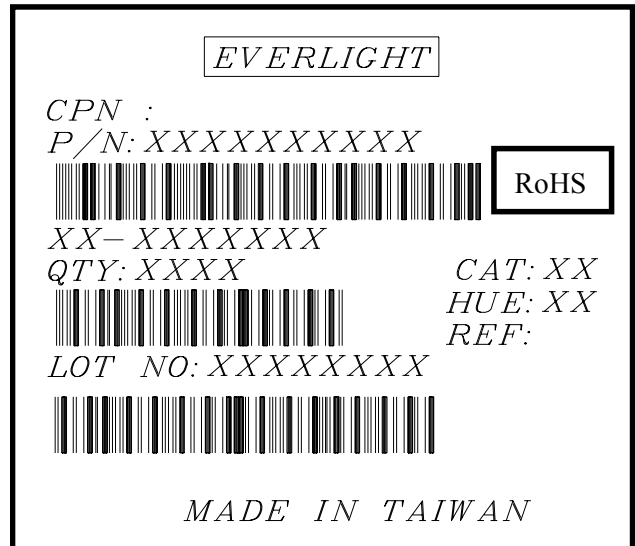

Reel Dimensions

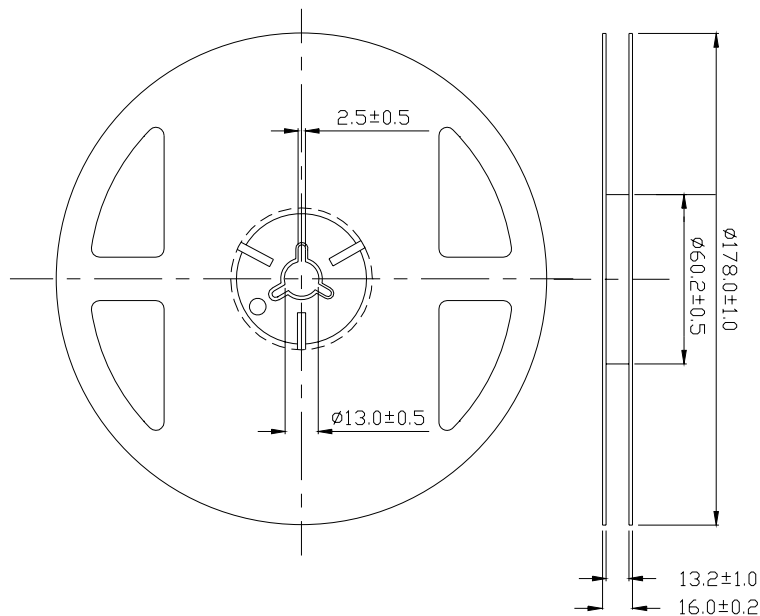

Note: Tolerance unless mentioned is ±0.1mm; Unit = mm



EVERLIGHT ELECTRONICS CO., LTD.

Technical Data Sheet - Preliminary

Luminosity White Color LED

67-235UWC/TR8

Carrier Tape Dimensions: Loaded Quantity 2000 pcs Per Reel.

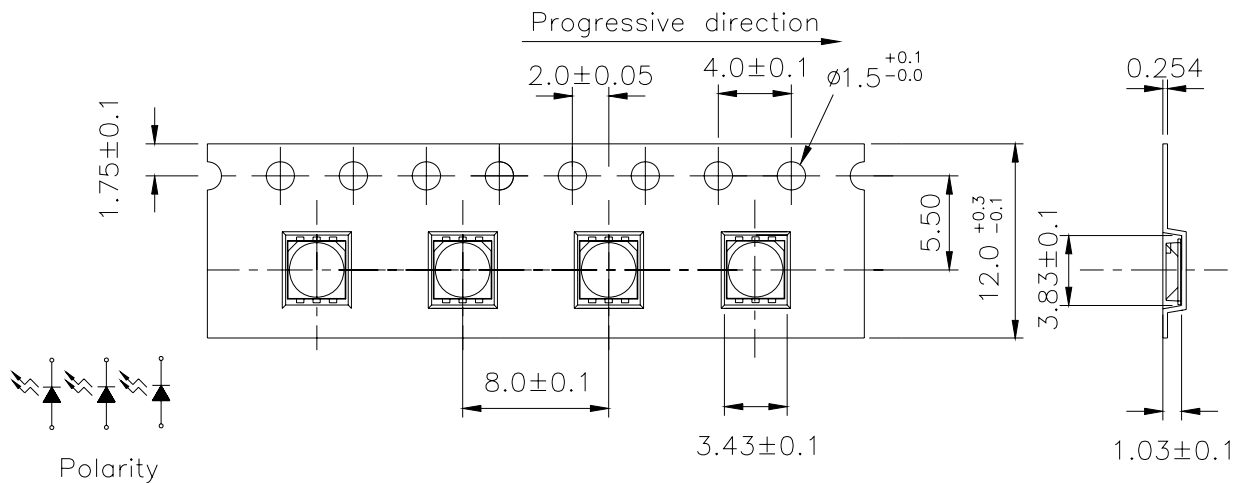

Note: Tolerance unless mentioned is ± 0.1 mm; Unit = mm

Moisture Resistant Packaging

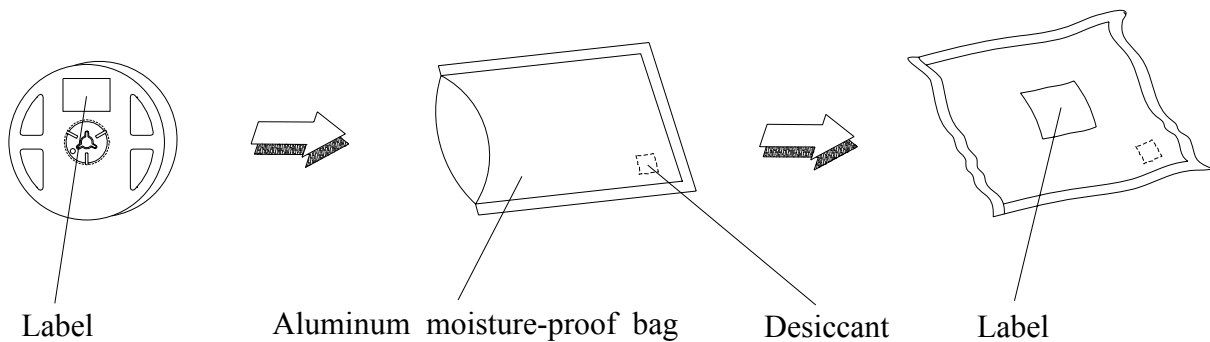

**Technical Data Sheet - Preliminary****Luminosity White Color LED****67-235UWC/TR8****Reliability Test Items and Conditions**

The reliability of products shall be satisfied with items listed below.

Confidence level : 90%

LTPD : 10%

No.	Items	Test Condition	Test Hours/Cycles	Sample Size	Ac/Re
1	Reflow Soldering	Temp. : 260°C±5°C Min. 5sec.	6 min	22 PCS.	0/1
2	Temperature Cycle	H : +100°C 15min ∫ 5 min L : -40°C 15min	300 Cycles	22 PCS.	0/1
3	Thermal Shock	H : +100°C 5min ∫ 10 sec L : -10°C 5min	300 Cycles	22 PCS.	0/1
4	High Temperature Storage	Temp. : 100°C	1000 Hrs.	22 PCS.	0/1
5	Low Temperature Storage	Temp. : -40°C	1000 Hrs.	22 PCS.	0/1
6	DC Operating Life	I _F = 20 mA	1000 Hrs.	22 PCS.	0/1
7	High Temperature / High Humidity	85°C / 85%RH	1000 Hrs.	22 PCS.	0/1



Technical Data Sheet - Preliminary

Luminosity White Color LED

67-235UWC/TR8

Precautions for Use

1. Over-current-proof

Customer must apply resistors for protection; otherwise slight voltage shift will cause big current change (Burn out will happen).

2. Storage

2.1 Do not open moisture proof bag before the products are ready to use.

2.2 Before opening the package: The LEDs should be kept at 30°C or less and 90%RH or less.

2.3 After opening the package: The LED's floor life is 1 year under 30°C or less and 60% RH or less. If unused LEDs remain, it should be stored in moisture proof packages.

2.4 If the moisture absorbent material (silica gel) has faded away or the LEDs have exceeded the storage time, baking treatment should be performed using the following conditions.

Baking treatment: 60±5°C for 24 hours.

3. Soldering Condition

3.1 Pb-free solder temperature profile

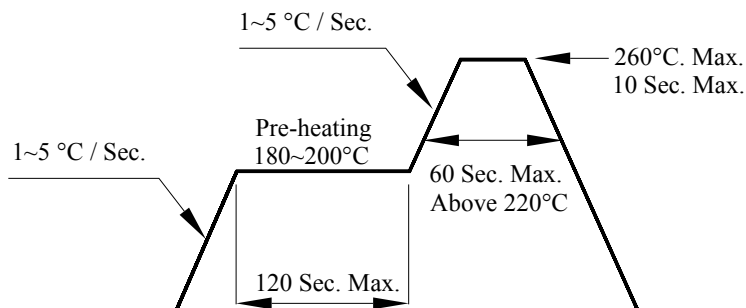

3.2 Reflow soldering should not be done more than two times.

3.3 When soldering, do not put stress on the LEDs during heating.

3.4 After soldering, do not warp the circuit board.



EVERLIGHT ELECTRONICS CO., LTD.

Technical Data Sheet - Preliminary

Luminosity White Color LED

67-235UWC/TR8

4. Soldering Iron

Each terminal is to go to the tip of soldering iron temperature less than 350°C for 3 seconds within once in less than the soldering iron capacity 25W. Leave two seconds and more intervals, and do soldering of each terminal. Be careful because the damage of the product is often started at the time of the hand solder.

5. Repairing

Repair should not be done after the LEDs have been soldered. When repairing is unavoidable, a double-head soldering iron should be used (as below figure). It should be confirmed beforehand whether the characteristics of the LEDs will or will not be damaged by repairing.

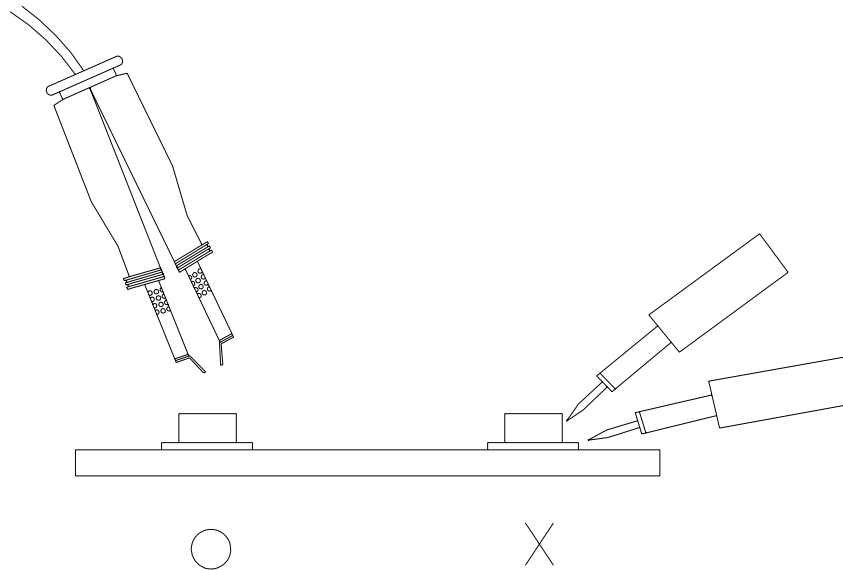

EVERLIGHT ELECTRONICS CO., LTD.
Office: No 25, Lane 76, Sec 3, Chung Yang Rd,
Tucheng, Taipei 236, Taiwan, R.O.C

Tel: 886-2-2267-2000, 2267-9936
Fax: 886-2267-6244, 2267-6189, 2267-6306
<http://www.everlight.com>