

International IOR Rectifier

60CTQ045PbF

SCHOTTKY RECTIFIER

60 Amp

$$I_{F(AV)} = 60\text{Amp}$$

$$V_R = 45\text{V}$$

Major Ratings and Characteristics

Characteristics	Values	Units
$I_{F(AV)}$ Rectangular waveform (Per Device)	60	A
I_{FRM} @ $T_C = 113^\circ\text{C}$ (Per Leg)	60	A
V_{RRM}	45	V
I_{FSM} @ $t_p = 5\ \mu\text{s}$ sine	1500	A
V_F @ 30 Apk, $T_J = 125^\circ\text{C}$	0.53	V
T_J range	-65 to 150	$^\circ\text{C}$

Description/ Features

This center tap Schottky rectifier has been optimized for low reverse leakage at high temperature. The proprietary barrier technology allows for reliable operation up to 150°C junction temperature. Typical applications are in switching power supplies, converters, free-wheeling diodes, and reverse battery protection.

- 150°C T_J operation
- Center tap TO-220 package
- Low forward voltage drop
- High purity, high temperature epoxy encapsulation for enhanced mechanical strength and moisture resistance
- High frequency operation
- Guard ring for enhanced ruggedness and long term reliability
- Lead-Free ("PbF" suffix)

Case Styles

60CTQ045PbF

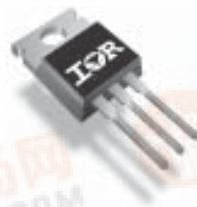

TO-220

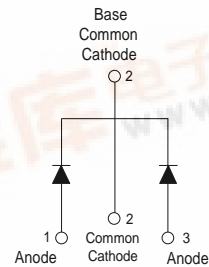

Voltage Ratings

Parameters	60CTQ045PbF
V_R Max. DC Reverse Voltage (V)	45
V_{RWM} Max. Working Peak Reverse Voltage (V)	

Absolute Maximum Ratings

Parameters	Values	Units	Conditions
$I_{F(AV)}$ Max. Average Forward Current (Per Leg) (Per Device)	30	A	50% duty cycle @ $T_C = 113^\circ\text{C}$, rectangular wave form
	60		
I_{FRM} Peak Repetitive Forward Current (Per Leg)	60	A	Rated V_R , square wave, 20kHz $T_C = 113^\circ\text{C}$
I_{FSM} Max. Peak One Cycle Non -Repetitive Surge Current (Per Leg)	1500	A	Following any rated load condition and with rated V_{RRM} applied
	300		
E_{AS} Non -Repetitive Avalanche Energy (Per Leg)	20	mJ	$T_J = 25^\circ\text{C}$, $I_{AS} = 3\text{Amps}$, $L = 4.40\text{mH}$
I_{AR} Repetitive Avalanche Current (Per Leg)	3	A	Current decaying linearly to zero in 1 μsec Frequency limited by T_J max. $V_A = 1.5 \times V_R$ typical

Electrical Specifications

Parameters	Typ.	Max.	Units	Conditions
V_{FM} Max. Forward Voltage Drop (1)	0.51	0.56	V	@ 30A $T_J = 25^\circ\text{C}$
	0.66	0.72	V	@ 60A
	0.48	0.53	V	@ 30A $T_J = 125^\circ\text{C}$
	0.68	0.75	V	@ 60A
I_{RM} Max. Instantaneous Reverse Current	0.33	2	mA	$T_J = 25^\circ\text{C}$ Rated DC voltage
	145	250	mA	$T_J = 125^\circ\text{C}$
C_T Max. Junction Capacitance	2000		pF	$V_R = 5V_{DC}$ (test signal range 100Khz to 1Mhz) 25°C
L_S Typical Series Inductance	8.0		nH	Measured from top of terminal to mounting plane
dv/dt Max. Voltage Rate of Change (Rated V_R)	10000		V/ μs	

(1) Pulse Width < 300 μs , Duty Cycle <2%

Thermal-Mechanical Specifications

Parameters	Values	Units	Conditions
T_J Max. Junction Temperature Range	-65 to 150	$^\circ\text{C}$	
T_{stg} Max. Storage Temperature Range	-65 to 175	$^\circ\text{C}$	
R_{thJC} Max. Thermal Resistance Junction to Case (Per Leg)	1.2	$^\circ\text{C}/\text{W}$	DC operation
R_{thCS} Typical Thermal Resistance Case to Heatsink	0.50	$^\circ\text{C}/\text{W}$	Mounting surface, smooth and greased
wt Approximate Weight	2 (0.07)	g (oz.)	
T Mounting Torque	Min. 6 (5)	Kg-cm (lbf-in)	Non-lubricated threads
	Max. 12 (10)		
Marking Device	60CTQ045		

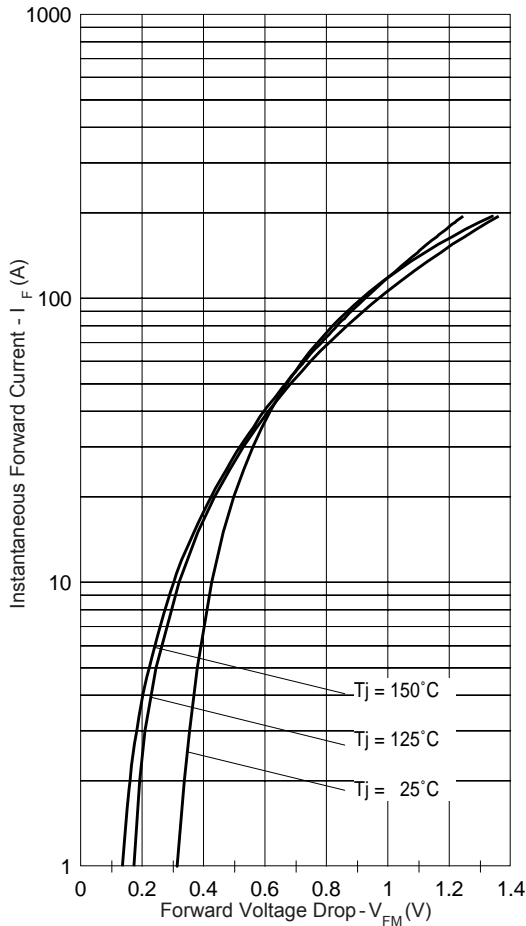

Fig. 1 - Maximum Forward Voltage Drop Characteristics

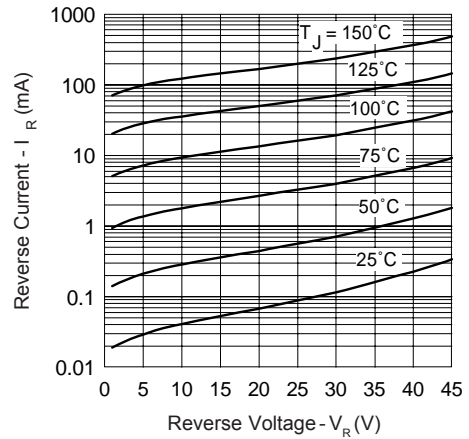

Fig. 2 - Typical Values of Reverse Current Vs. Reverse Voltage

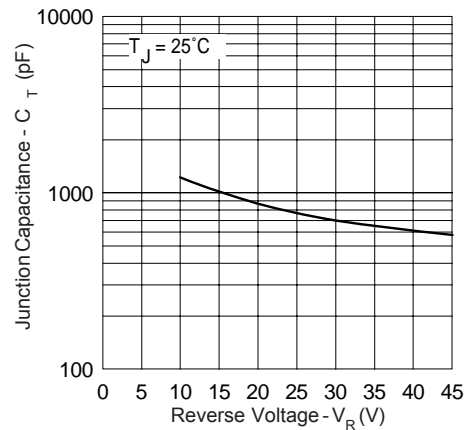

Fig. 3 - Typical Junction Capacitance Vs. Reverse Voltage

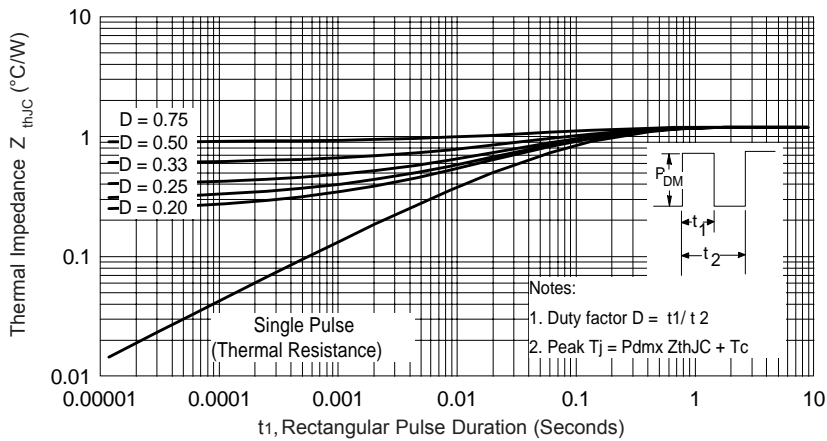

Fig. 4 - Max. Thermal Impedance Z_{thJC} Characteristics

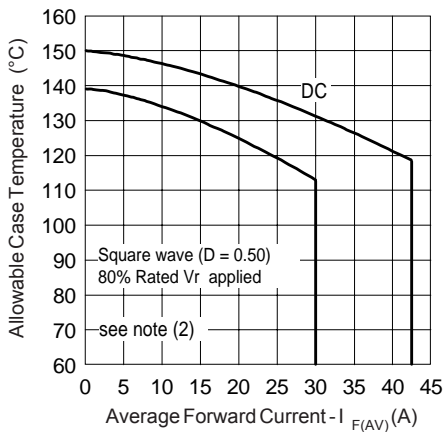

Fig. 5 - Max. Allowable Case Temperature Vs. Average Forward Current

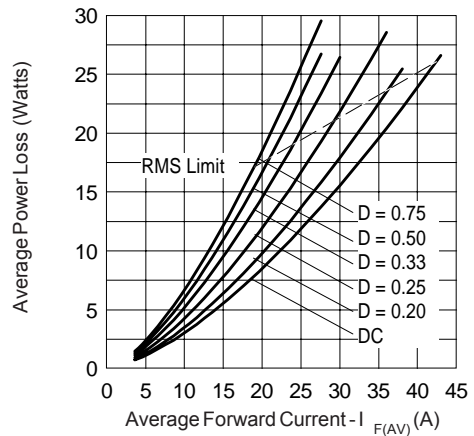

Fig. 6 - Forward Power Loss Characteristics

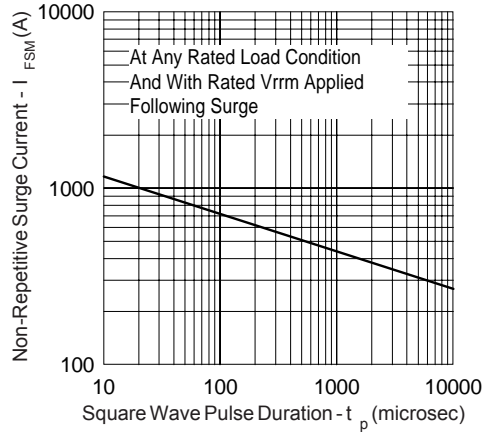

Fig. 7 - Max. Non-Repetitive Surge Current (Per Leg)

(2) Formula used: $T_c = T_j - (P_d + P_{d_{REV}}) \times R_{thJC}$

P_d = Forward Power Loss = $I_{F(AV)} \times V_{FM} @ (I_{F(AV)} / D)$ (see Fig. 6);

$P_{d_{REV}}$ = Inverse Power Loss = $V_{R1} \times I_R (1 - D)$; $I_R @ V_{R1} = 80\%$ rated V_R

Outline Table

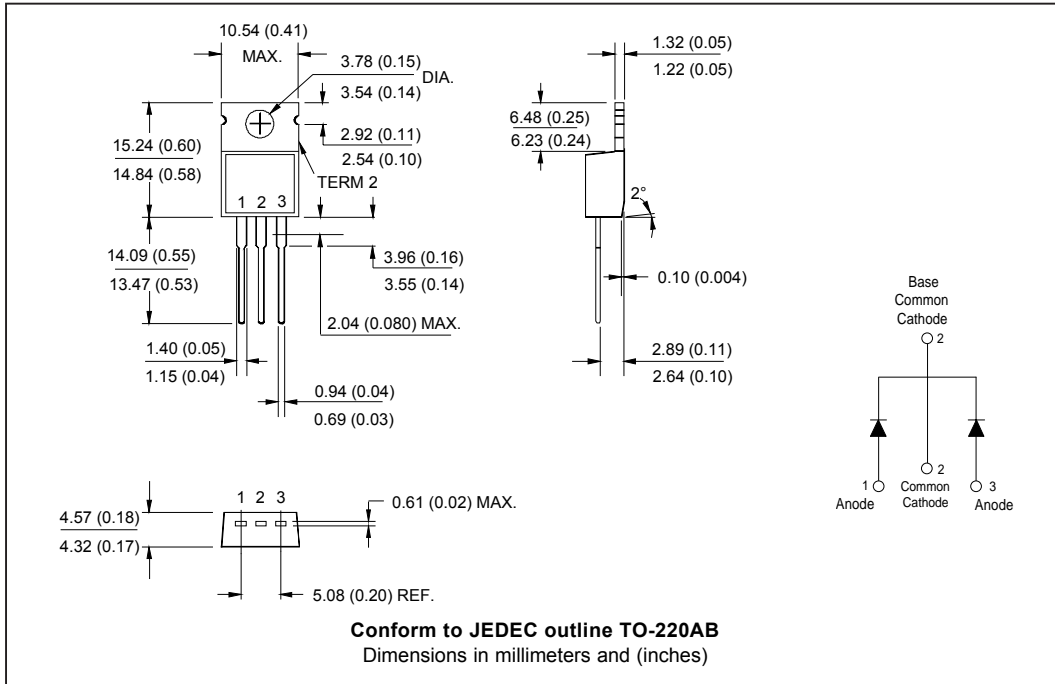

Part Marking Information

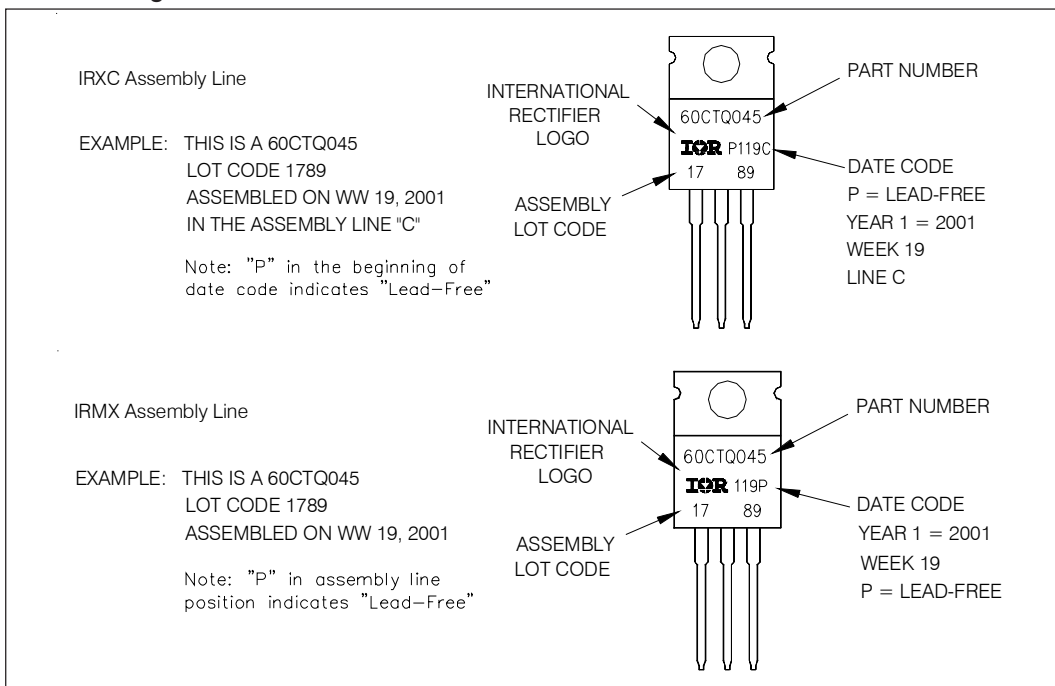

Ordering Information Table

Device Code													
	<table border="1"> <tr> <td style="padding: 5px;">60</td> <td style="padding: 5px;">C</td> <td style="padding: 5px;">T</td> <td style="padding: 5px;">Q</td> <td style="padding: 5px;">045</td> <td style="padding: 5px;">PbF</td> </tr> <tr> <td style="text-align: center;">①</td> <td style="text-align: center;">②</td> <td style="text-align: center;">③</td> <td style="text-align: center;">④</td> <td style="text-align: center;">⑤</td> <td style="text-align: center;">⑥</td> </tr> </table>	60	C	T	Q	045	PbF	①	②	③	④	⑤	⑥
60	C	T	Q	045	PbF								
①	②	③	④	⑤	⑥								
1	- Current Rating (60 = 60A)												
2	- Circuit Configuration C = Common Cathode												
3	- Package T = TO-220												
4	- Schottky "Q" Series												
5	- Voltage Rating (045 = 45V)												
6	- <ul style="list-style-type: none"> • none = Standard Production • PbF = Lead-Free 												
Tube Standard Pack Quantity : 50 pieces													

Data and specifications subject to change without notice.
This product has been designed and qualified for Industrial Level and Lead-Free.
Qualification Standards can be found on IR's Web site.

International
IR Rectifier

IR WORLD HEADQUARTERS: 233 Kansas St., El Segundo, California 90245, USA Tel: (310) 252-7105
TAC Fax: (310) 252-7309
Visit us at www.irf.com for sales contact information. 10/04