

DATA SHEET

74ALS161B/74ALS163B 4-bit binary counter

Product specification

1991 Feb 08

IC05 Data Handbook



4-bit binary counter

74ALS161B/74ALS163B

74ALS161B 4-bit binary counter, asynchronous reset

74ALS163B 4-bit binary counter, synchronous reset

FEATURES

- Synchronous counting and loading
- Two count enable inputs for n-bit cascading
- Positive edge-triggered clock
- Asynchronous reset (74ALS161B)
- Synchronous reset (74ALS163B)
- High speed synchronous expansion
- Typical count rate of 140MHz

TYPE	TYPICAL f_{MAX}	TYPICAL SUPPLY CURRENT (TOTAL)
74ALS161B	140MHz	10mA
74ALS163B	140MHz	10mA

ORDERING INFORMATION

DESCRIPTION	ORDER CODE	DRAWING NUMBER
	COMMERCIAL RANGE $V_{CC} = 5V \pm 10\%$, $T_{amb} = 0^{\circ}C$ to $+70^{\circ}C$	
16-pin plastic DIP	74ALS161BN, 74ALS163BN	SOT38-4
16-pin plastic SO	74ALS161BD, 74ALS163BD	SOT109-1
16-pin plastic SSOP Type II	74ALS161BDB, 74ALS163BDB	SOT338-1

DESCRIPTION

Synchronous presettable 4-bit binary counters (74ALS161B, 74ALS163B) feature an internal carry look-ahead and can be used for high speed counting. Synchronous operation is provided by having all flip-flops clocked simultaneously on the positive-going edge of the clock. The clock input is buffered.

The outputs of the counters may be preset to High or Low level. A Low level at the parallel enable (\overline{PE}) input disables the counting action and causes the data at the D0 – D3 inputs to be loaded into the counter on the positive-going edge of the clock (provided that the setup and hold requirements for \overline{PE} are met). Preset takes place regardless of the levels at count enable (CEP, CET) inputs.

A Low level at the master reset (\overline{MR}) input sets all the four outputs of the flip-flops (Q0 – Q3) in 74ALS161B to Low levels, regardless of the levels at CP, \overline{PE} , CET and CEP inputs (thus providing an asynchronous clear function).

For the 74ALS163B the clear function is synchronous. A Low level at the synchronous reset (\overline{SR}) input sets all four outputs of the flip-flops (Q0 – Q3) to Low levels after the next positive-going transition on the clock (CP) input (provided that the setup and hold time requirements for \overline{SR} are met). This action occurs regardless of the levels at CP, \overline{PE} , CET and CEP inputs. The synchronous reset feature enables the designer to modify the maximum count with only one external NAND gate (see Figure 1).

The carry look-ahead simplifies serial cascading of the counters. Both count enable (CEP and CET) inputs must be High to count. The CET input is fed forward to enable the TC output. The TC output thus enabled will produce a High output pulse of a duration approximately equal to the High level output of Q0. This pulse can be used to enable the next cascaded stage (see Figure 2).

The TC output is subjected to decoding spikes due to internal race conditions. Therefore, it is not recommended for use as clock or asynchronous reset for flip-flops, registers, or counters.

INPUT AND OUTPUT LOADING AND FAN-OUT TABLE

PINS	DESCRIPTION	74ALS (U.L.) HIGH/LOW	LOAD VALUE HIGH/LOW
D0 – D3	Data inputs	1.0/1.0	20 μ A/0.1mA
CEP	Count enable parallel input (active-Low)	1.0/1.0	20 μ A/0.1mA
CET	Count enable trickle input (active-Low)	1.0/1.0	20 μ A/0.1mA
CP	Clock input (active rising edge)	1.0/1.0	20 μ A/0.1mA
\overline{PE}	Parallel enable input (active-Low)	1.0/1.0	20 μ A/0.1mA
\overline{MR}	Asynchronous master reset input (active-Low) for 74ALS161B	1.0/1.0	20 μ A/0.1mA
\overline{SR}	Asynchronous reset input (active-Low) for 74ALS163B	1.0/1.0	20 μ A/0.1mA
Q0 – Q3	Flip-flop outputs	20/80	0.4mA/8mA
TC	Terminal count output (active-Low)	20/80	0.4mA/8mA

NOTE: One (1.0) ALS unit load is defined as: 20 μ A in the High state and 0.1mA in the Low state.

4-bit binary counter

74ALS161B/74ALS163B

STATE DIAGRAM

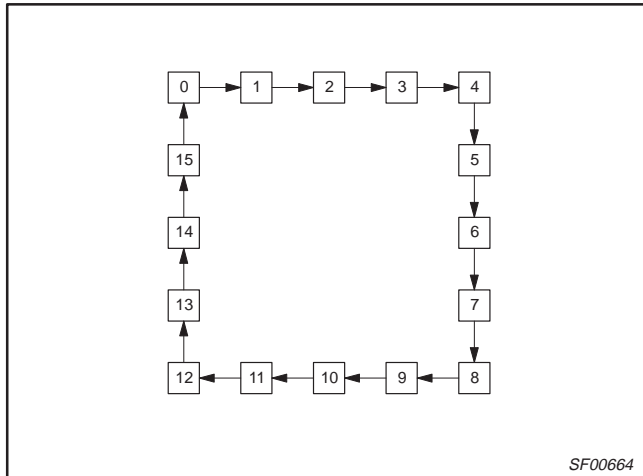

APPLICATIONS

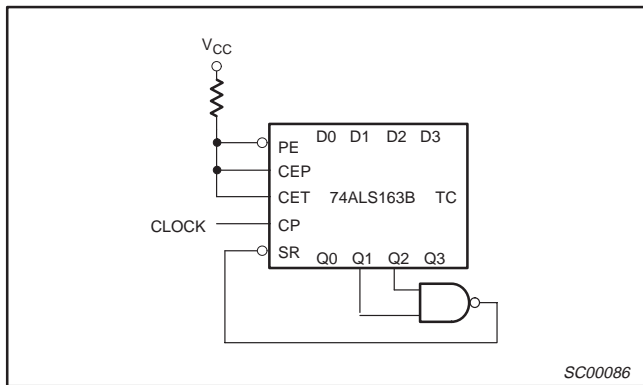

Figure 1. Maximum Count Modifying Scheme
Terminal Count = 6

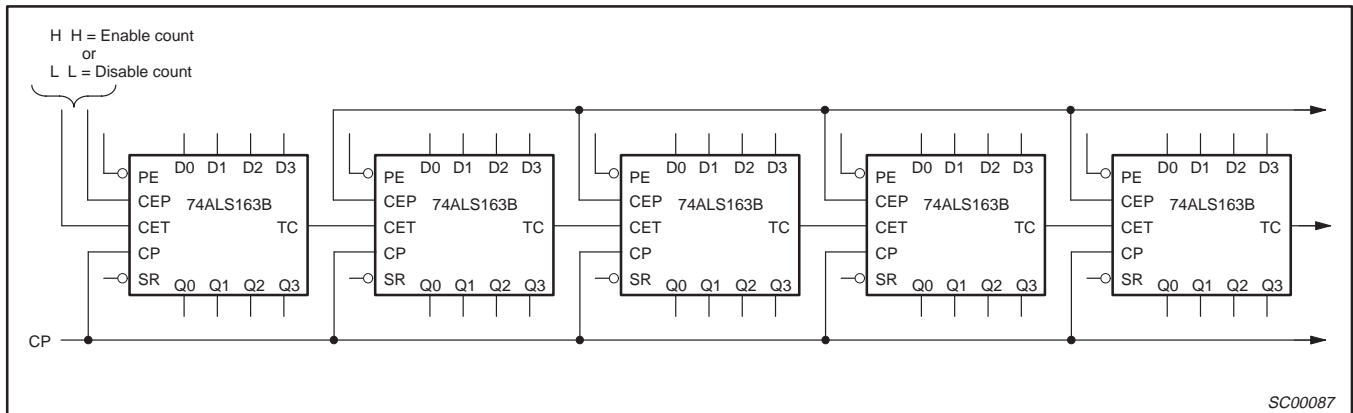
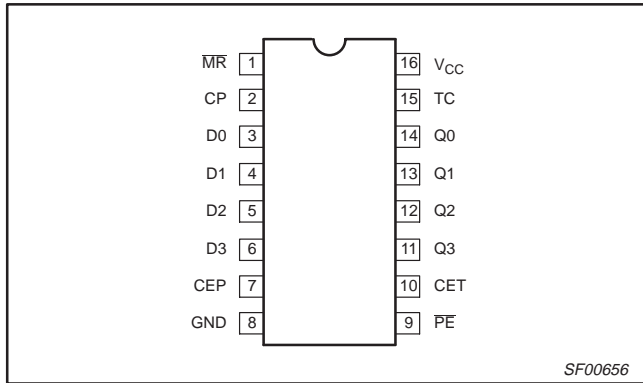

Figure 2. Synchronous Multistage Counting Scheme

4-bit binary counter

74ALS161B/74ALS163B

PIN CONFIGURATION – 74ALS161B



PIN CONFIGURATION – 74ALS163B

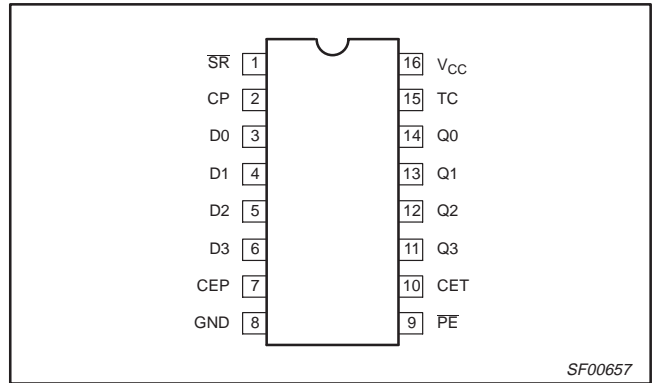

LOGIC SYMBOL – 74ALS161B

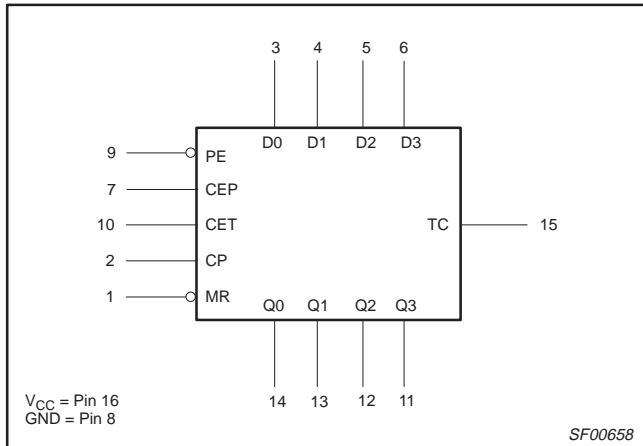

LOGIC SYMBOL – 74ALS163B

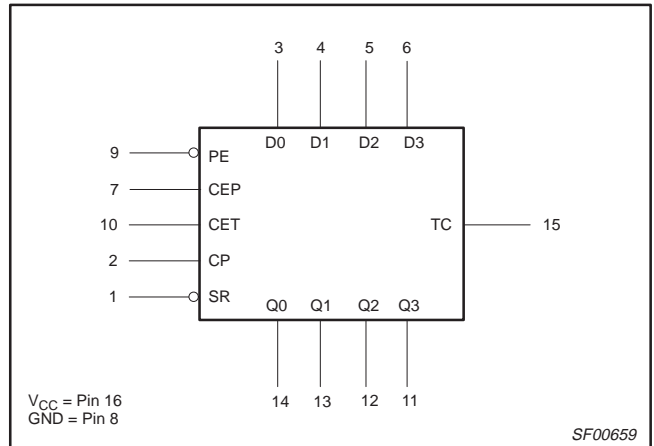

IEC/IEEE SYMBOL – 74ALS161B

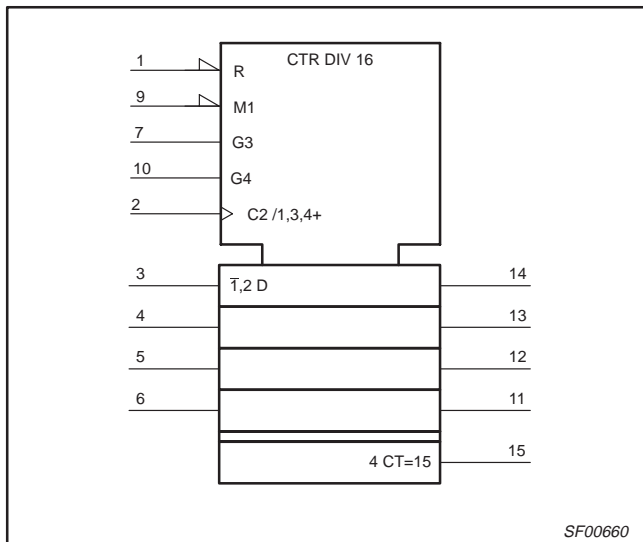

IEC/IEEE SYMBOL – 74ALS163B

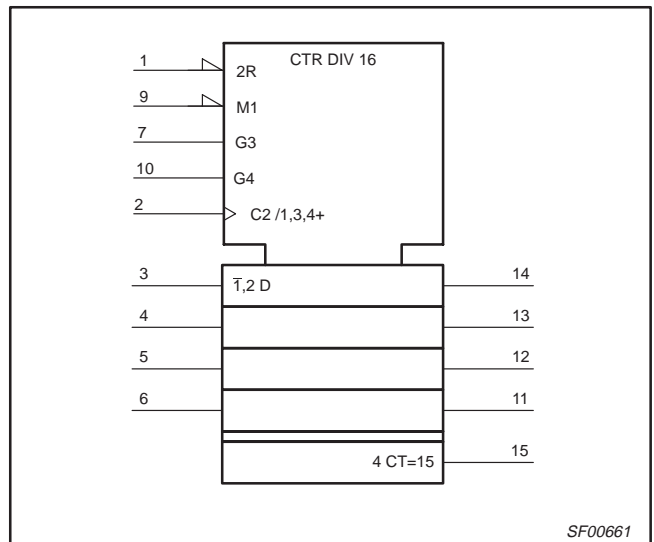

4-bit binary counter

74ALS161B/74ALS163B

LOGIC DIAGRAM – 74ALS161B

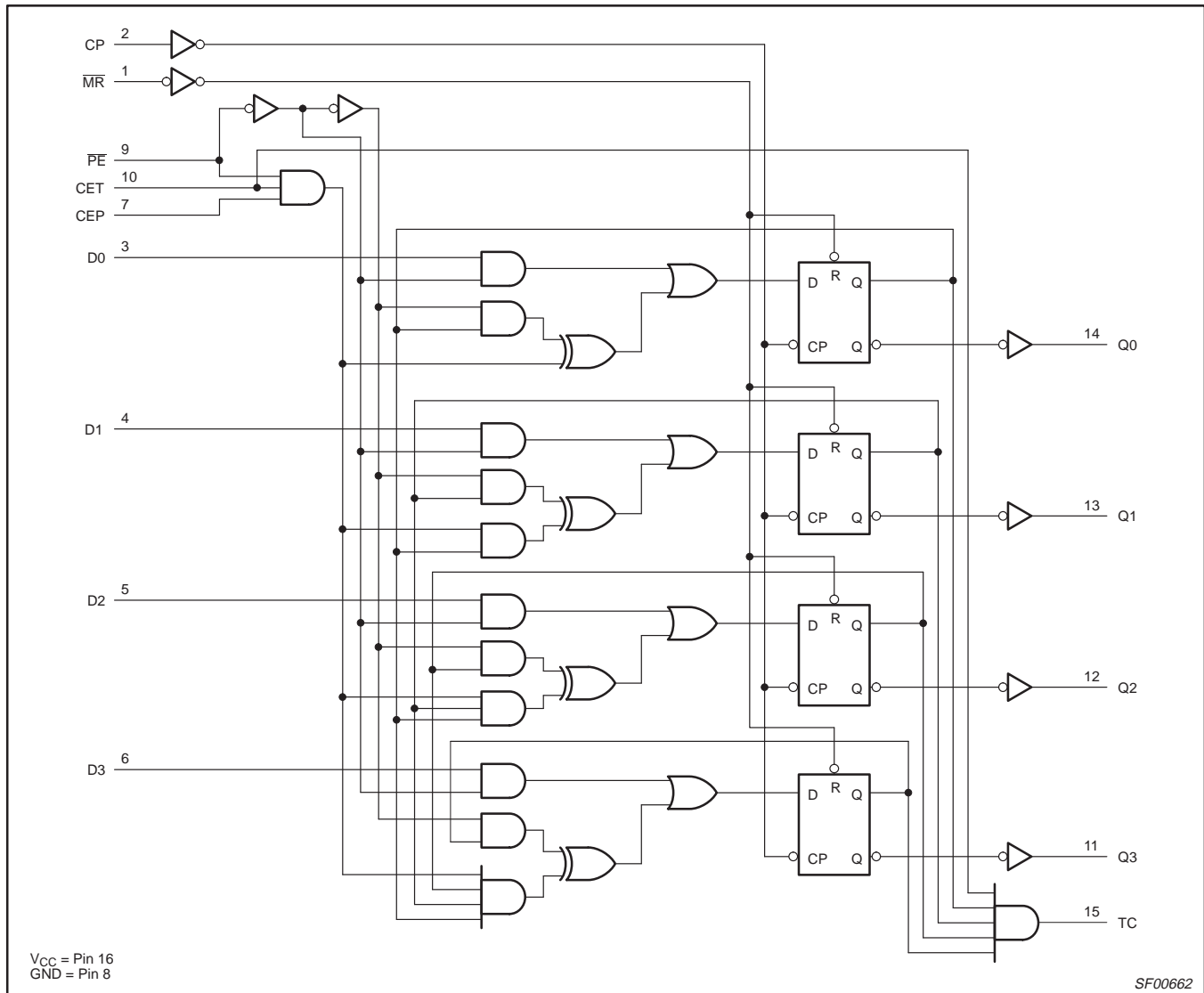

MODE SELECTION FUNCTION TABLE – 74ALS161B

INPUTS					OUTPUTS			OPERATING MODE
\overline{MR}	CP	CEP	CET	\overline{PE}	Dn	Qn	TC	
L	X	X	X	X	X	L	L	Reset (clear)
H	↑	X	X	l	l	L	L	Parallel load
H	↑	X	X	l	h	H	(a)	
H	↑	h	h	h	X	count	(a)	Count
h	X	l	X	h	X	qn	(a)	Hold (do nothing)
h	X	X	l	h	X	qn	L	

H = High-voltage level

h = High state must be present one setup time before the Low-to-High clock transition

L = Low-voltage level

l = Low state must be present one setup time before the Low-to-High clock transition

qn = Lower case letters indicate the state of the referenced output prior to the Low-to-High clock transition

X = Don't care

(a) = The output is High when CET is High and the counter is at terminal count (HHHH)

↑ = Low-to-High clock transition

4-bit binary counter

74ALS161B/74ALS163B

LOGIC DIAGRAM – 74ALS163B

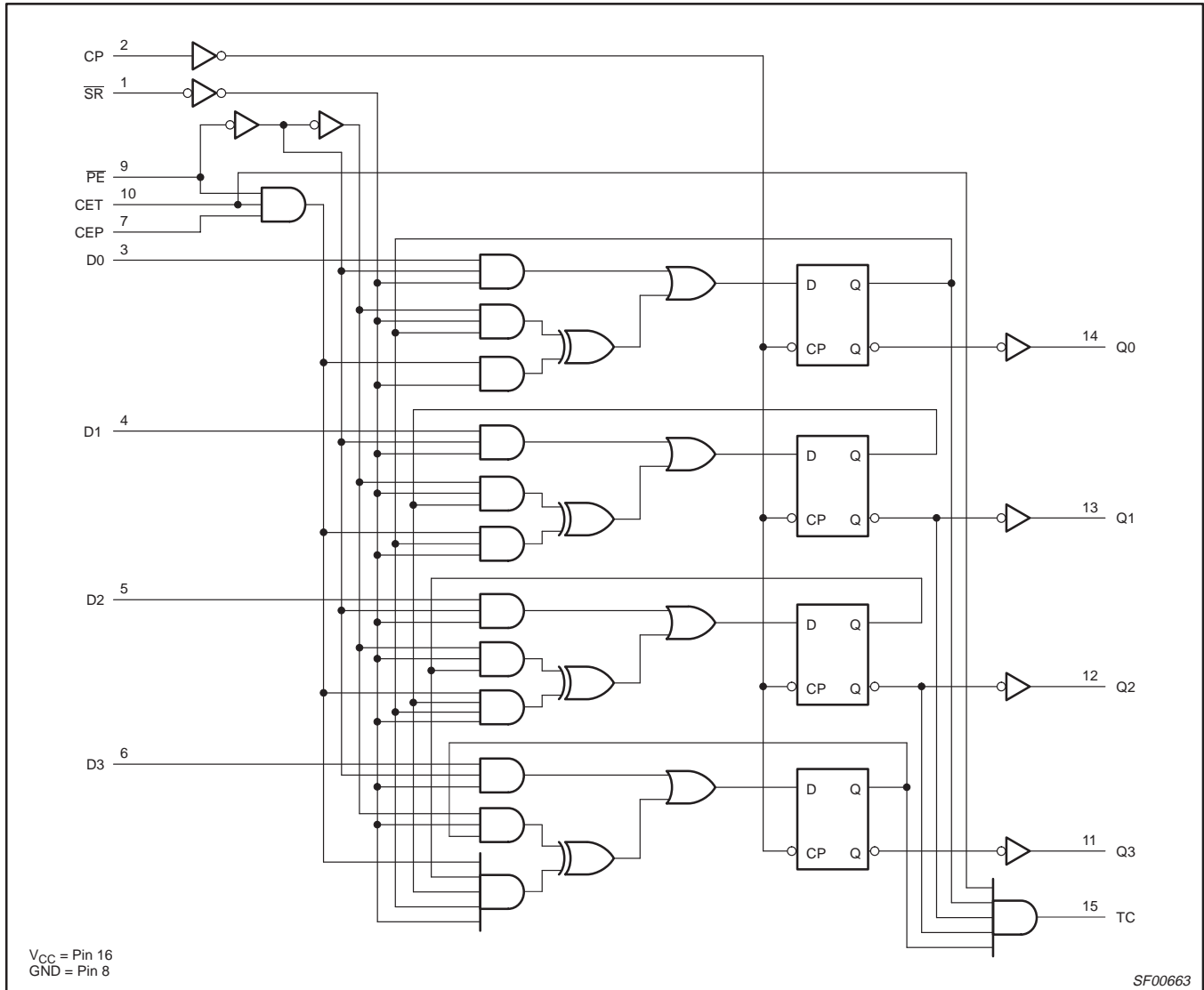

MODE SELECTION FUNCTION TABLE – 74ALS163B

INPUTS					OUTPUTS			OPERATING MODE
SR-bar	CP	CEP	CET	PE-bar	Dn	Qn	TC	
l	↑	X	X	X	X	L	L	Reset (clear)
h	↑	X	X	l	l	L	L	Parallel load
h	↑	X	X	l	h	H	(a)	
h	↑	h	h	h	X	count	(a)	Count
h	X	l	X	h	X	qn	(a)	Hold (do nothing)
h	X	X	l	h	X	qn	L	

H = High-voltage level
 h = High state must be present one setup time before the Low-to-High clock transition
 L = Low-voltage level
 l = Low state must be present one setup time before the Low-to-High clock transition
 qn = Lower case letters indicate the state of the referenced output prior to the Low-to-High clock transition
 X = Don't care
 (a) = The output is High when CET is High and the counter is at terminal count (HHHH)
 ↑ = Low-to-High clock transition

4-bit binary counter

74ALS161B/74ALS163B

ABSOLUTE MAXIMUM RATINGS

(Operation beyond the limit set forth in this table may impair the useful life of the device.
Unless otherwise noted these limits are over the operating free air temperature range.)

SYMBOL	PARAMETER	RATING	UNIT
V_{CC}	Supply voltage	-0.5 to +7.0	V
V_{IN}	Input voltage	-0.5 to +7.0	V
I_{IN}	Input current	-30 to +5	mA
V_{OUT}	Voltage applied to output in High output state	-0.5 to V_{CC}	V
I_{OUT}	Current applied to output in Low output state	16	mA
T_{amb}	Operating free-air temperature range	0 to +70	°C
T_{stg}	Storage temperature range	-65 to +150	°C

RECOMMENDED OPERATING CONDITIONS

SYMBOL	PARAMETER	LIMITS			UNIT
		MIN	NOM	MAX	
V_{CC}	Supply voltage	4.5	5.0	5.5	V
V_{IH}	High-level input voltage	2.0			V
V_{IL}	Low-level input voltage			0.8	V
I_{IK}	Input clamp current			-18	mA
I_{OH}	High-level output current			-0.4	mA
I_{OL}	Low-level output current			8	mA
T_{amb}	Operating free-air temperature range	0		+70	°C

DC ELECTRICAL CHARACTERISTICS

(Over recommended operating free-air temperature range unless otherwise noted.)

SYMBOL	PARAMETER	TEST CONDITIONS ¹	LIMITS			UNIT
			MIN	TYP ²	MAX	
V_{OH}	High-level output voltage	$V_{CC} = \pm 10\%$, $V_{IL} = \text{MAX}$, $V_{IH} = \text{MIN}$, $I_{OH} = -0.4\text{mA}$	$V_{CC} - 2$			V
V_{OL}	Low-level output voltage	$V_{CC} = \text{MIN}$, $V_{IL} = \text{MAX}$, $V_{IH} = \text{MIN}$, $I_{OL} = 4\text{mA}$		0.25	0.40	V
				0.35	0.50	V
V_{IK}	Input clamp voltage	$V_{CC} = \text{MIN}$, $I_I = I_{IK}$		-0.73	-1.5	V
I_I	Input current at minimum input voltage	$V_{CC} = \text{MAX}$, $V_I = 7.0\text{V}$			0.1	mA
I_{IH}	High-level input current	$V_{CC} = \text{MAX}$, $V_I = 2.7\text{V}$			20	μA
I_{IL}	Low-level input current	$V_{CC} = \text{MAX}$, $V_I = 0.4\text{V}$			-0.1	mA
I_O	Output current ³	$V_{CC} = \text{MAX}$, $V_O = 2.25\text{V}$	-30		-112	mA
I_{CC}	Supply current (total)	$V_{CC} = \text{MAX}$		10	21	mA

NOTES:

- For conditions shown as MIN or MAX, use the appropriate value specified under recommended operating conditions for the applicable type.
- All typical values are at $V_{CC} = 5\text{V}$, $T_{amb} = 25^\circ\text{C}$.
- The output conditions have been chosen to produce a current that closely approximates one half of the true short-circuit output current, I_{OS} .

4-bit binary counter

74ALS161B/74ALS163B

AC ELECTRICAL CHARACTERISTICS

SYMBOL	PARAMETER		TEST CONDITION	LIMITS		UNIT
				$T_{amb} = 0^{\circ}\text{C to } +70^{\circ}\text{C}$ $V_{CC} = +5.0\text{V} \pm 10\%$ $C_L = 50\text{pF}, R_L = 500\Omega$		
				MIN	MAX	
f_{MAX}	Maximum clock frequency		Waveform 1	100		MHz
t_{PLH} t_{PHL}	Propagation delay CP to Qn		Waveform 1	4.0 6.0	13.0 16.0	ns
t_{PLH} t_{PHL}	Propagation delay CP to TC		Waveform 1	6.0 8.0	16.0 16.0	ns
t_{PLH} t_{PHL}	Propagation delay CET to TC		Waveform 2	3.0 3.0	10.0 10.0	ns
t_{PHL}	Propagation delay MR to Qn	74ALS161B	Waveform 3	8.0	15.0	ns
t_{PHL}	Propagation delay MR to TC	74ALS163B	Waveform 3	11.0	19.0	ns

AC ELECTRICAL CHARACTERISTICS

SYMBOL	PARAMETER		TEST CONDITION	LIMITS		UNIT
				$T_{amb} = 0^{\circ}\text{C to } +70^{\circ}\text{C}$ $V_{CC} = +5.0\text{V} \pm 10\%$ $C_L = 50\text{pF}, R_L = 500\Omega$		
				MIN	MAX	
$t_{su(H)}$ $t_{su(L)}$	Setup time, High or Low Dn to CP		Waveform 6	8.0 8.0		ns
$t_h(H)$ $t_h(L)$	Hold time, High or Low Dn to CP		Waveform 6	0.0 0.0		ns
$t_{su(H)}$ $t_{su(L)}$	Setup time, High or Low PE or SR to CP		Waveform 5 or 6	10.0 10.0		ns
$t_h(H)$ $t_h(L)$	Hold time, High or Low PE or SR to CP		Waveform 6	0.0 0.0		ns
$t_{su(H)}$ $t_{su(L)}$	Setup time, High or Low CET or CEP to CP		Waveform 4	10.0 10.0		ns
$t_h(H)$ $t_h(L)$	Hold time, High or Low CET or CEP to CP		Waveform 4	0.0 0.0		ns
$t_w(H)$ $t_w(L)$	CP Pulse width (load), High or Low		Waveform 1	5.0 5.0		ns
$t_w(H)$ $t_w(L)$	CP Pulse width (count), High or Low		Waveform 1	5.0 5.0		ns
$t_w(L)$	MR or SR Pulse width, Low		Waveform 3	5.0		ns
t_{REC}	Recovery time, CR or SR to CP		Waveform 3	10.0		ns

4-bit binary counter

74ALS161B/74ALS163B

AC WAVEFORMS

For all waveforms, $V_M = 1.3V$.

The shaded areas indicate when the input is permitted to change for predictable output performance.

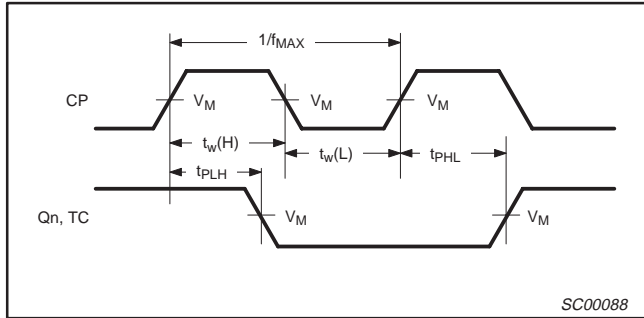

Waveform 1. Propagation Delay for Clock Input to Output, Clock Pulse Width, and Maximum Clock Frequency

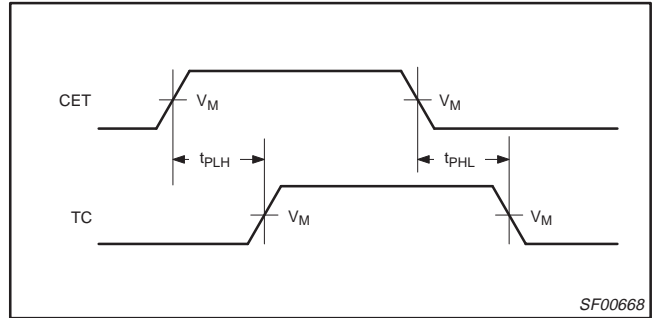

Waveform 2. Propagation Delay for CET to TC Output

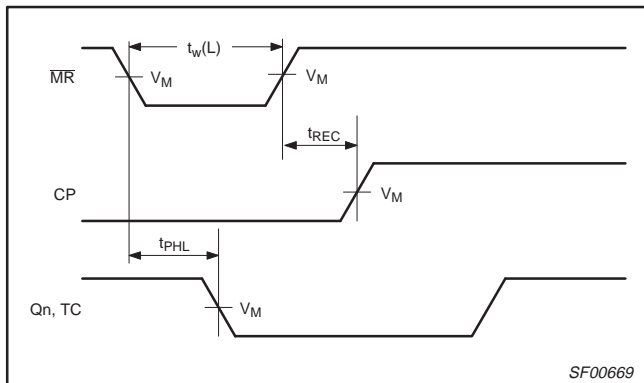

Waveform 3. Master Reset Pulse Width, Master Reset to Output Delay, and Master Reset to Clock Recovery Time

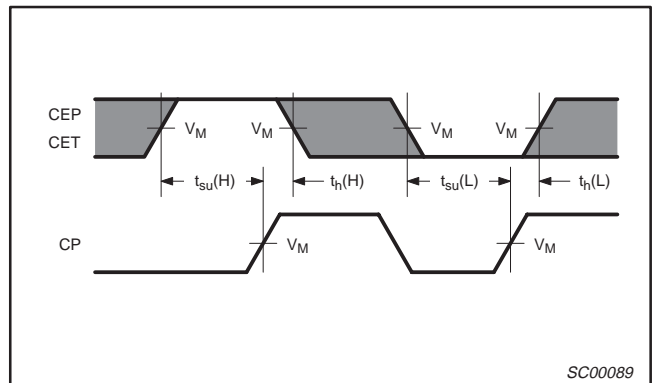

Waveform 4. CEP and CET Setup and Hold Times

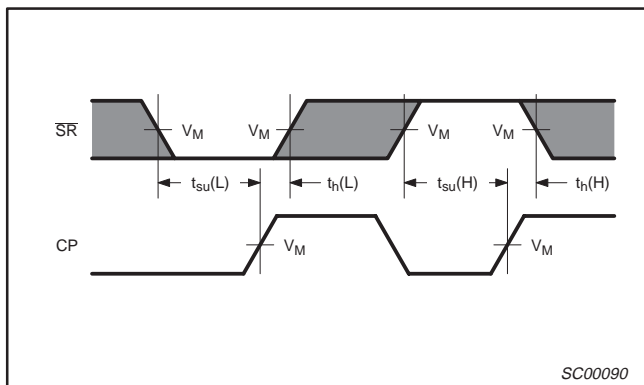

Waveform 5. Synchronous Reset Setup and Hold Times

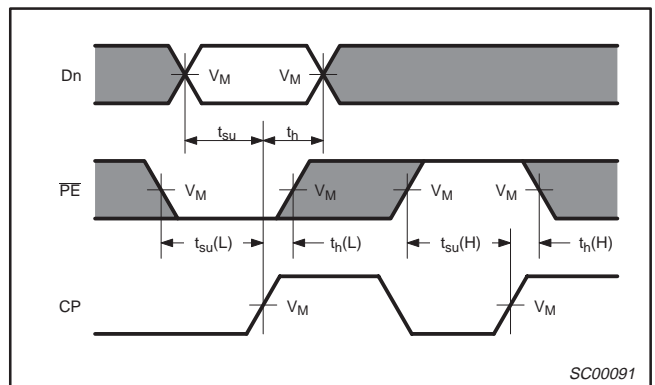

Waveform 6. Data and Parallel Enable Setup and Hold Times

4-bit binary counter

74ALS161B/74ALS163B

TEST CIRCUIT AND WAVEFORMS

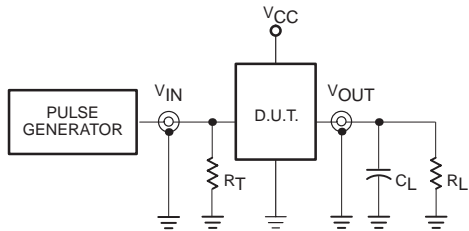

Test Circuit for Totem-pole Outputs

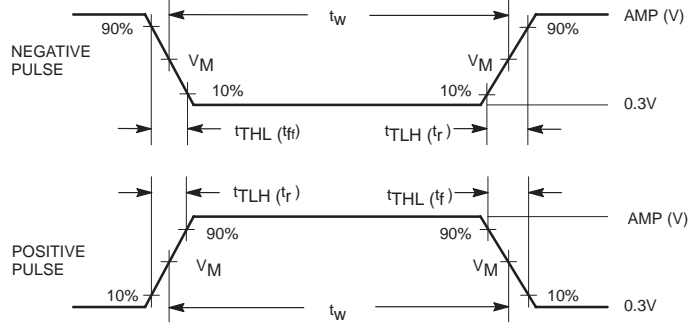

Input Pulse Definition

DEFINITIONS:

- R_L = Load resistor; see AC electrical characteristics for value.
- C_L = Load capacitance includes jig and probe capacitance; see AC electrical characteristics for value.
- R_T = Termination resistance should be equal to Z_{OUT} of pulse generators.

Family	INPUT PULSE REQUIREMENTS					
	Amplitude	V_M	Rep.Rate	t_w	t_{TLH}	t_{THL}
74ALS	3.5V	1.3V	1MHz	500ns	2.0ns	2.0ns

4-bit binary counter

74ALS161B
74ALS163B

DIP16: plastic dual in-line package; 16 leads (300 mil)

SOT38-4

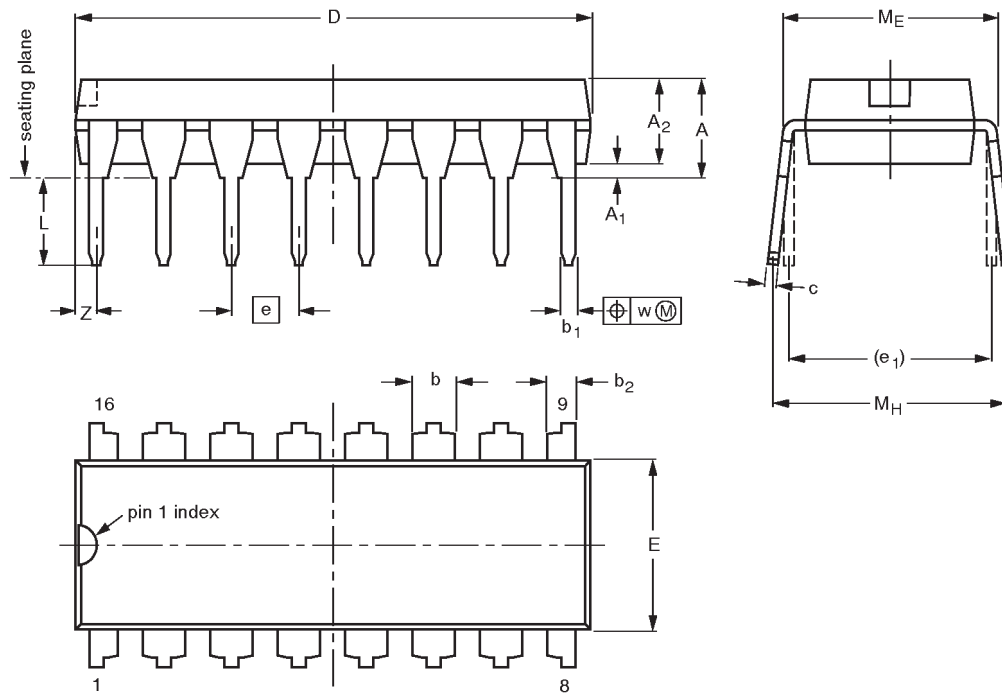

DIMENSIONS (inch dimensions are derived from the original mm dimensions)

UNIT	A max.	A ₁ min.	A ₂ max.	b	b ₁	b ₂	c	D ⁽¹⁾	E ⁽¹⁾	e	e ₁	L	M _E	M _H	w	Z ⁽¹⁾ max.
mm	4.2	0.51	3.2	1.73 1.30	0.53 0.38	1.25 0.85	0.36 0.23	19.50 18.55	6.48 6.20	2.54	7.62	3.60 3.05	8.25 7.80	10.0 8.3	0.254	0.76
inches	0.17	0.020	0.13	0.068 0.051	0.021 0.015	0.049 0.033	0.014 0.009	0.77 0.73	0.26 0.24	0.10	0.30	0.14 0.12	0.32 0.31	0.39 0.33	0.01	0.030

Note

1. Plastic or metal protrusions of 0.25 mm maximum per side are not included.

OUTLINE VERSION	REFERENCES				EUROPEAN PROJECTION	ISSUE DATE
	IEC	JEDEC	EIAJ			
SOT38-4						92-11-17 95-01-14

4-bit binary counter

74ALS161B
74ALS163B

SO16: plastic small outline package; 16 leads; body width 3.9 mm

SOT109-1

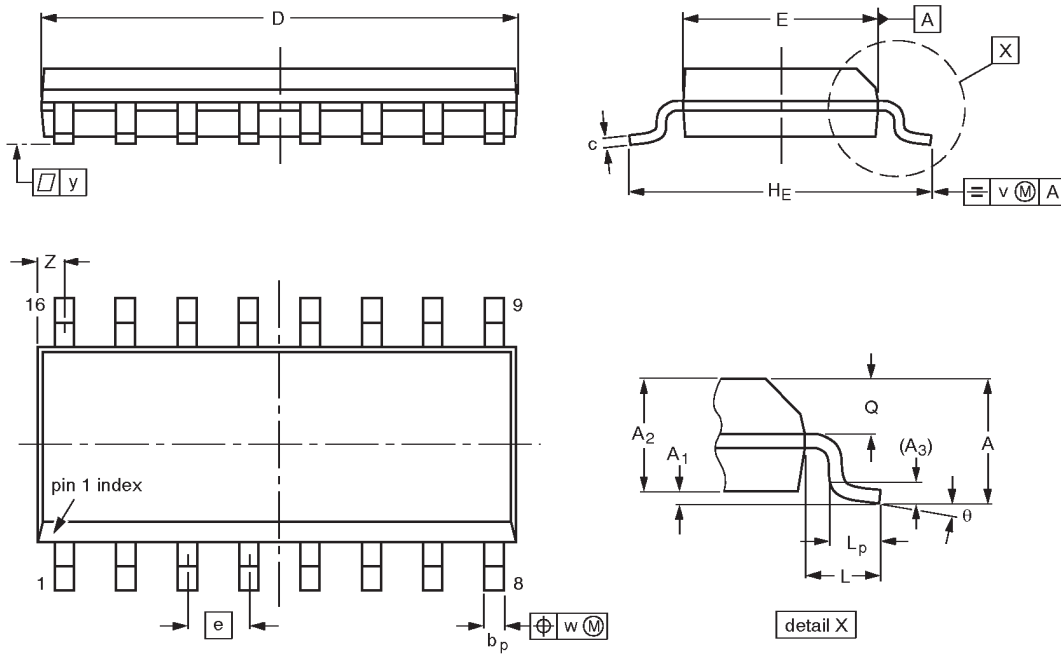

DIMENSIONS (inch dimensions are derived from the original mm dimensions)

UNIT	A max.	A ₁	A ₂	A ₃	b _p	c	D ⁽¹⁾	E ⁽¹⁾	e	H _E	L	L _p	Q	v	w	y	Z ⁽¹⁾	θ
mm	1.75	0.25 0.10	1.45 1.25	0.25	0.49 0.36	0.25 0.19	10.0 9.8	4.0 3.8	1.27	6.2 5.8	1.05	1.0 0.4	0.7 0.6	0.25	0.25	0.1	0.7 0.3	8° 0°
inches	0.069	0.0098 0.0039	0.057 0.049	0.01	0.019 0.014	0.0098 0.0075	0.39 0.38	0.16 0.15	0.050	0.24 0.23	0.041	0.039 0.016	0.028 0.020	0.01	0.01	0.004	0.028 0.012	

Note

1. Plastic or metal protrusions of 0.15 mm maximum per side are not included.

OUTLINE VERSION	REFERENCES				EUROPEAN PROJECTION	ISSUE DATE
	IEC	JEDEC	EIAJ			
SOT109-1	076E07S	MS-012AC				91-08-13 95-01-23

4-bit binary counter

74ALS161B
74ALS163B

SSOP16: plastic shrink small outline package; 16 leads; body width 5.3 mm

SOT338-1

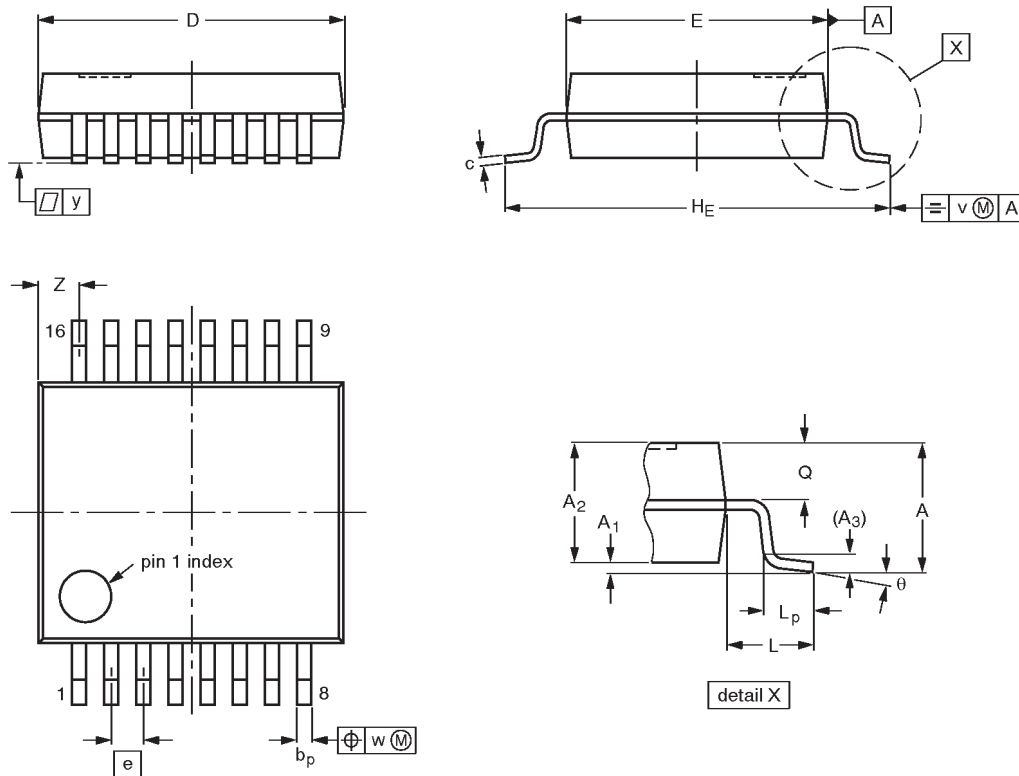

DIMENSIONS (mm are the original dimensions)

UNIT	A max.	A ₁	A ₂	A ₃	b _p	c	D ⁽¹⁾	E ⁽¹⁾	e	H _E	L	L _p	Q	v	w	y	Z ⁽¹⁾	θ
mm	2.0	0.21 0.05	1.80 1.65	0.25	0.38 0.25	0.20 0.09	6.4 6.0	5.4 5.2	0.65	7.9 7.6	1.25	1.03 0.63	0.9 0.7	0.2	0.13	0.1	1.00 0.55	8° 0°

Note

1. Plastic or metal protrusions of 0.25 mm maximum per side are not included.

OUTLINE VERSION	REFERENCES				EUROPEAN PROJECTION	ISSUE DATE
	IEC	JEDEC	EIAJ			
SOT338-1		MO-150AC				94-01-14 95-02-04

4-bit binary counter

74ALS161B
74ALS163B

DEFINITIONS

Data Sheet Identification	Product Status	Definition
<i>Objective Specification</i>	Formative or in Design	This data sheet contains the design target or goal specifications for product development. Specifications may change in any manner without notice.
<i>Preliminary Specification</i>	Preproduction Product	This data sheet contains preliminary data, and supplementary data will be published at a later date. Philips Semiconductors reserves the right to make changes at any time without notice in order to improve design and supply the best possible product.
<i>Product Specification</i>	Full Production	This data sheet contains Final Specifications. Philips Semiconductors reserves the right to make changes at any time without notice, in order to improve design and supply the best possible product.

Philips Semiconductors and Philips Electronics North America Corporation reserve the right to make changes, without notice, in the products, including circuits, standard cells, and/or software, described or contained herein in order to improve design and/or performance. Philips Semiconductors assumes no responsibility or liability for the use of any of these products, conveys no license or title under any patent, copyright, or mask work right to these products, and makes no representations or warranties that these products are free from patent, copyright, or mask work right infringement, unless otherwise specified. Applications that are described herein for any of these products are for illustrative purposes only. Philips Semiconductors makes no representation or warranty that such applications will be suitable for the specified use without further testing or modification.

LIFE SUPPORT APPLICATIONS

Philips Semiconductors and Philips Electronics North America Corporation Products are not designed for use in life support appliances, devices, or systems where malfunction of a Philips Semiconductors and Philips Electronics North America Corporation Product can reasonably be expected to result in a personal injury. Philips Semiconductors and Philips Electronics North America Corporation customers using or selling Philips Semiconductors and Philips Electronics North America Corporation Products for use in such applications do so at their own risk and agree to fully indemnify Philips Semiconductors and Philips Electronics North America Corporation for any damages resulting from such improper use or sale.

Philips Semiconductors
811 East Arques Avenue
P.O. Box 3409
Sunnyvale, California 94088-3409
Telephone 800-234-7381

© Copyright Philips Electronics North America Corporation 1997
All rights reserved. Printed in U.S.A.

Let's make things better.