

# DATA SHEET

**74ALS251**

8-input multiplexer (3-State)

Product specification  
IC05 Data Handbook

1991 Feb 08

# 8-input multiplexer (3-State)

# 74ALS251

### FEATURES

- 8-to-1 multiplexing
- On chip decoding
- Multifunction capability
- Inverting and non-inverting outputs
- Both outputs are 3-State for further multiplexer expansion

### DESCRIPTION

The 74ALS251 is a logic implementation of a single 8-position switch with the switch position controlled by the state of three select (S0, S1, S2) inputs. True (Y) and complementary ( $\bar{Y}$ ) outputs are both provided.

The output enable ( $\overline{OE}$ ) is active Low. When  $\overline{OE}$  is High, both outputs are in High impedance state, allowing multiple connections to a common bus without driving nor loading the bus significantly.

When the outputs of more than one device are tied together, the user must ensure that there is no overlap in the active-Low portion of the output enable voltages in order to avoid high currents that could exceed the maximum current rating.

### PIN CONFIGURATION

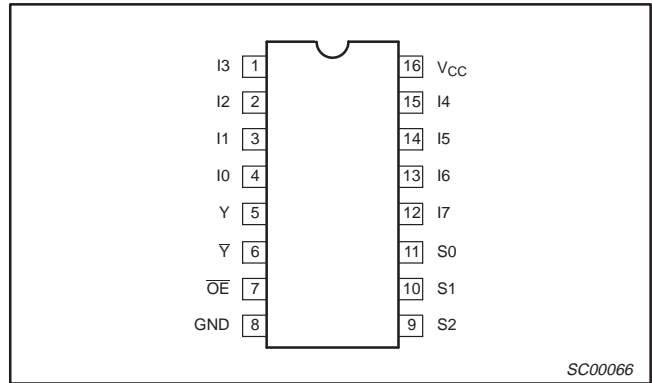

### ORDERING INFORMATION

DESCRIPTION	ORDER CODE	DRAWING NUMBER
	COMMERCIAL RANGE V <sub>CC</sub> = 5V ±10%, T <sub>amb</sub> = 0°C to +70°C	
16-pin plastic DIP	74ALS251N	SOT38-4
16-pin plastic SO	74ALS251D	SOT109-1

TYPE	TYPICAL PROPAGATION DELAY	TYPICAL SUPPLY CURRENT (TOTAL)
74ALS251	7.0ns	7.5mA

### INPUT AND OUTPUT LOADING AND FAN-OUT TABLE

PINS	DESCRIPTION	74ALS (U.L.) HIGH/LOW	LOAD VALUE HIGH/LOW
I0 – I7	Data inputs	1.0/1.0	20µA/0.1mA
S0 – S2	Select inputs	1.0/1.0	20µA/0.1mA
$\overline{OE}$	Output Enable input (active-Low)	1.0/1.0	20µA/0.1mA
Y, $\bar{Y}$	Data outputs	130/240	2.5mA/24mA

**NOTE:** One (1.0) ALS unit load is defined as: 20µA in the High state and 0.1mA in the Low state.

### LOGIC SYMBOL

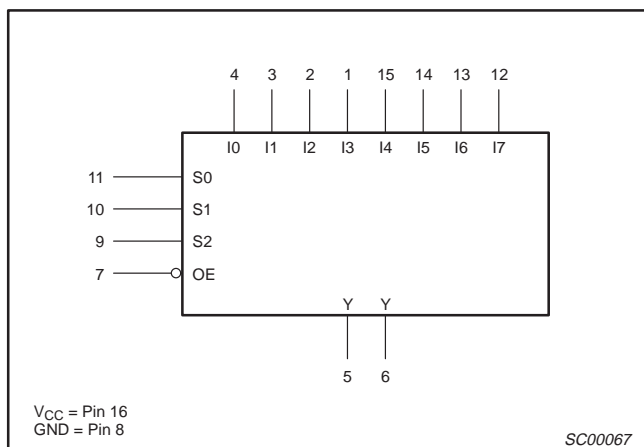

### IEC/IEEE SYMBOL

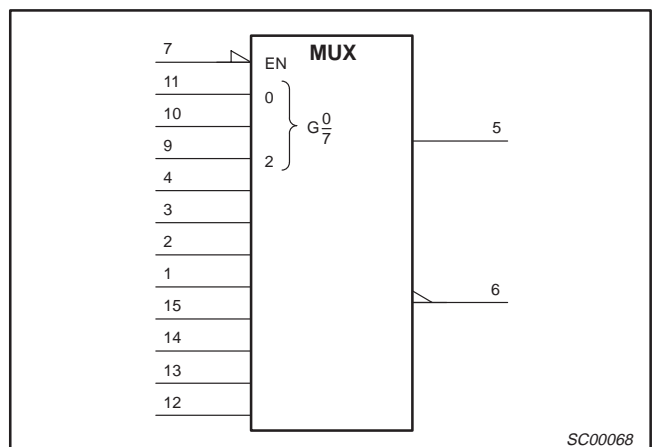

# 8-input multiplexer (3-State)

# 74ALS251

## LOGIC DIAGRAM

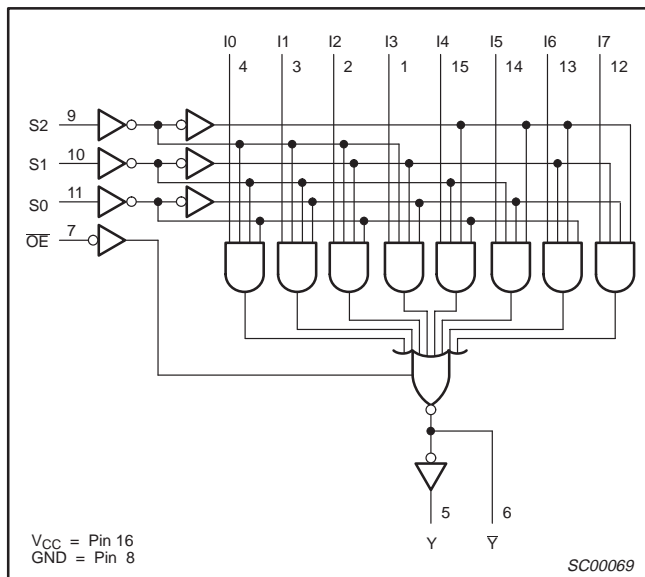

## FUNCTION TABLE

INPUTS				OUTPUTS	
S2	S1	S0	OE	Y	Y
X	X	X	H	Z	Z
L	L	L	L	I0	I0
L	L	H	L	I1	I1
L	H	L	L	I2	I2
L	H	H	L	I3	I3
H	L	L	L	I4	I4
H	L	H	L	I5	I5
H	H	L	L	I6	I6
H	H	H	L	I7	I7

H = High voltage level  
L = Low voltage level  
X = Don't care  
Z = High impedance "off" state

## ABSOLUTE MAXIMUM RATINGS

(Operation beyond the limit set forth in this table may impair the useful life of the device. Unless otherwise noted these limits are over the operating free air temperature range.)

SYMBOL	PARAMETER	RATING	UNIT
$V_{CC}$	Supply voltage	-0.5 to +7.0	V
$V_{IN}$	Input voltage	-0.5 to +7.0	V
$I_{IN}$	Input current	-30 to +5	mA
$V_{OUT}$	Voltage applied to output in High output state	-0.5 to $V_{CC}$	V
$I_{OUT}$	Current applied to output in Low output state	48	mA
$T_{amb}$	Operating free-air temperature range	0 to +70	°C
$T_{stg}$	Storage temperature range	-65 to +150	°C

## RECOMMENDED OPERATING CONDITIONS

SYMBOL	PARAMETER	LIMITS			UNIT
		MIN	NOM	MAX	
$V_{CC}$	Supply voltage	4.5	5.0	5.5	V
$V_{IH}$	High-level input voltage	2.0			V
$V_{IL}$	Low-level input voltage			0.8	V
$I_{IK}$	Input clamp current			-18	mA
$I_{OH}$	High-level output current			-2.6	mA
$I_{OL}$	Low-level output current			24	mA
$T_{amb}$	Operating free-air temperature range	0		+70	°C

## 8-input multiplexer (3-State)

74ALS251

## DC ELECTRICAL CHARACTERISTICS

(Over recommended operating free-air temperature range unless otherwise noted.)

SYMBOL	PARAMETER	TEST CONDITIONS <sup>1</sup>	LIMITS			UNIT	
			MIN	TYP <sup>2</sup>	MAX		
V <sub>OH</sub>	High-level output voltage	V <sub>CC</sub> ±10%, V <sub>IL</sub> = MAX, V <sub>IH</sub> = MIN	I <sub>OH</sub> = -0.4mA	V <sub>CC</sub> - 2		V	
			I <sub>OH</sub> = -2.6mA	2.4	3.2	V	
V <sub>OL</sub>	Low-level output voltage	V <sub>CC</sub> = MIN, V <sub>IL</sub> = MAX, V <sub>IH</sub> = MIN	I <sub>OL</sub> = 12mA		0.25	0.40	V
			I <sub>OL</sub> = 24mA		0.35	0.50	V
V <sub>IK</sub>	Input clamp voltage	V <sub>CC</sub> = MIN, I <sub>I</sub> = I <sub>IK</sub>		-0.73	-1.5	V	
I <sub>I</sub>	Input current at maximum input voltage	V <sub>CC</sub> = MAX, V <sub>I</sub> = 7.0V			0.1	mA	
I <sub>IH</sub>	High-level input current	V <sub>CC</sub> = MAX, V <sub>I</sub> = 2.7V			20	μA	
I <sub>IL</sub>	Low-level input current	V <sub>CC</sub> = MAX, V <sub>I</sub> = 0.4V			-0.1	mA	
I <sub>OZH</sub>	Off-state output current, High-level voltage applied	V <sub>CC</sub> = MAX, V <sub>I</sub> = 2.7V			20	μA	
I <sub>OZL</sub>	Off-state output current, Low-level voltage applied	V <sub>CC</sub> = MAX, V <sub>I</sub> = 0.4V			-20	μA	
I <sub>O</sub>	Output current <sup>3</sup>	V <sub>CC</sub> = MAX, V <sub>O</sub> = 2.25V	-30		-112	mA	
I <sub>CC</sub>	Supply current (total)	V <sub>CC</sub> = MAX	I <sub>CC</sub>	7.0	10	mA	
			I <sub>CCZ</sub>	9.0	14	mA	

## NOTES:

- For conditions shown as MIN or MAX, use the appropriate value specified under recommended operating conditions for the applicable type.
- All typical values are at V<sub>CC</sub> = 5V, T<sub>amb</sub> = 25°C.
- The output conditions have been chosen to produce a current that closely approximates one half of the true short-circuit output current, I<sub>OS</sub>.

## AC ELECTRICAL CHARACTERISTICS

SYMBOL	PARAMETER	TEST CONDITION	LIMITS		UNIT
			T <sub>amb</sub> = 0°C to +70°C V <sub>CC</sub> = +5.0V ± 10% C <sub>L</sub> = 50pF, R <sub>L</sub> = 500Ω		
			MIN	MAX	
t <sub>PLH</sub> t <sub>PHL</sub>	Propagation delay In to Y	Waveform 2	4.0 4.0	12.0 12.0	ns
t <sub>PLH</sub> t <sub>PHL</sub>	Propagation delay In to $\bar{Y}$	Waveform 1	3.0 6.0	10.0 15.0	ns
t <sub>PLH</sub> t <sub>PHL</sub>	Propagation delay Sn to Y	Waveform 1, 2	5.0 7.0	15.0 16.0	ns
t <sub>PLH</sub> t <sub>PHL</sub>	Propagation delay Sn to $\bar{Y}$	Waveform 1, 2	8.0 5.0	17.0 15.0	ns
t <sub>PZH</sub> t <sub>PZL</sub>	Propagation delay OE to Y	Waveform 3 Waveform 4	2.0 3.0	8.0 9.0	ns
t <sub>PHZ</sub> t <sub>PLZ</sub>	Propagation delay OE to Y	Waveform 3 Waveform 4	2.0 1.0	8.0 7.0	ns
t <sub>PZH</sub> t <sub>PZL</sub>	Propagation delay OE to $\bar{Y}$	Waveform 3 Waveform 4	2.0 3.0	8.0 9.0	ns
t <sub>PHZ</sub> t <sub>PLZ</sub>	Propagation delay OE to $\bar{Y}$	Waveform 3 Waveform 4	2.0 1.0	8.0 7.0	ns

# 8-input multiplexer (3-State)

# 74ALS251

## AC WAVEFORMS

For all waveforms,  $V_M = 1.3V$ .

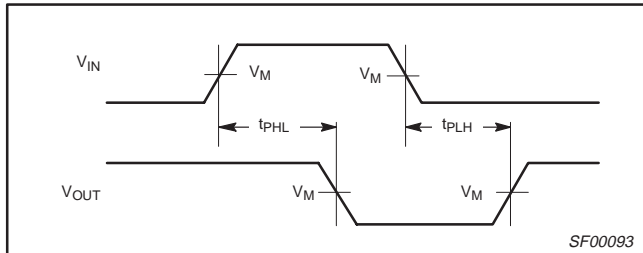

Waveform 1. Propagation Delay for Inverting Output

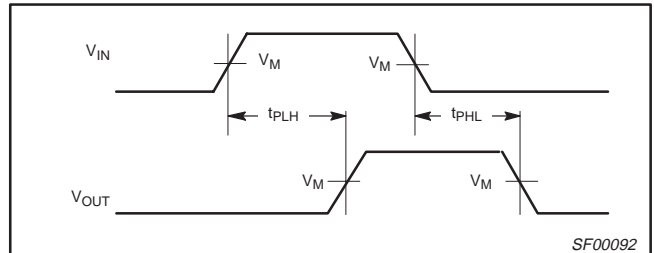

Waveform 2. Propagation Delay for Non-inverting Output

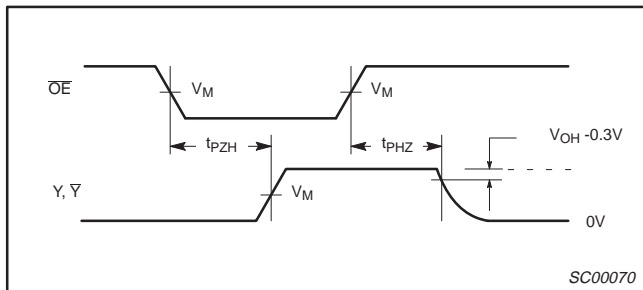

Waveform 3. 3-State Output Enable Time to High Level and Output Disable Time from High Level

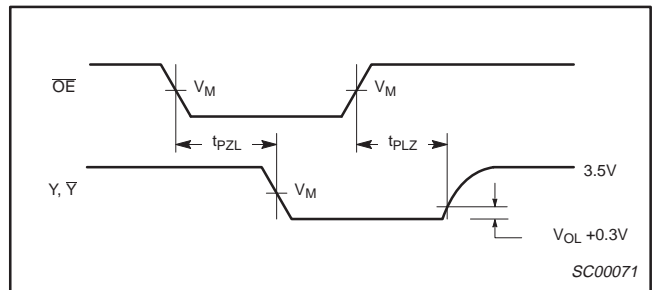

Waveform 4. 3-State Output Enable Time to Low Level and Output Disable Time from Low Level

## TEST CIRCUIT AND WAVEFORMS

**Test Circuit for 3-State Outputs**

SWITCH POSITION	
TEST	SWITCH
$t_{pLZ}, t_{pZL}$	closed
All other	open

**DEFINITIONS:**  
 $R_L$  = Load resistor; see AC electrical characteristics for value.  
 $C_L$  = Load capacitance includes jig and probe capacitance; see AC electrical characteristics for value.  
 $R_T$  = Termination resistance should be equal to  $Z_{OUT}$  of pulse generators.

**Input Pulse Definition**

Family	INPUT PULSE REQUIREMENTS					
	Amplitude	$V_M$	Rep.Rate	$t_w$	$t_{TLH}$	$t_{THL}$
74ALS	3.5V	1.3V	1MHz	500ns	2.0ns	2.0ns

8-input multiplexer (3-State)

74ALS251

DIP16: plastic dual in-line package; 16 leads (300 mil)

SOT38-4

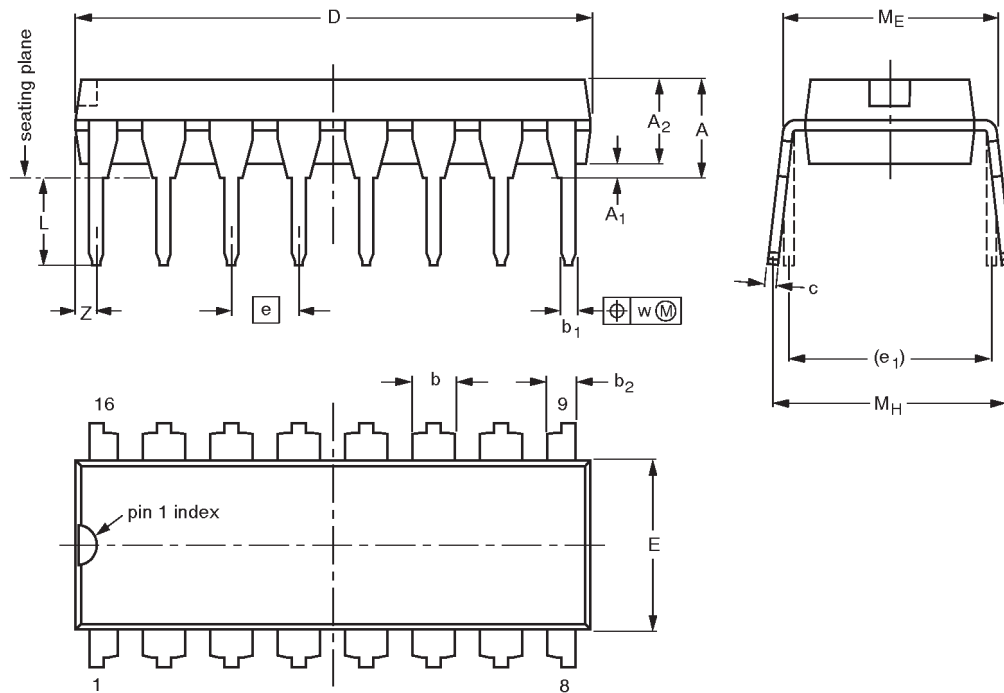

DIMENSIONS (inch dimensions are derived from the original mm dimensions)

UNIT	A max.	A <sub>1</sub> min.	A <sub>2</sub> max.	b	b <sub>1</sub>	b <sub>2</sub>	c	D <sup>(1)</sup>	E <sup>(1)</sup>	e	e <sub>1</sub>	L	M <sub>E</sub>	M <sub>H</sub>	w	Z <sup>(1)</sup> max.
mm	4.2	0.51	3.2	1.73 1.30	0.53 0.38	1.25 0.85	0.36 0.23	19.50 18.55	6.48 6.20	2.54	7.62	3.60 3.05	8.25 7.80	10.0 8.3	0.254	0.76
inches	0.17	0.020	0.13	0.068 0.051	0.021 0.015	0.049 0.033	0.014 0.009	0.77 0.73	0.26 0.24	0.10	0.30	0.14 0.12	0.32 0.31	0.39 0.33	0.01	0.030

Note

1. Plastic or metal protrusions of 0.25 mm maximum per side are not included.

OUTLINE VERSION	REFERENCES				EUROPEAN PROJECTION	ISSUE DATE
	IEC	JEDEC	EIAJ			
SOT38-4						92-11-17 95-01-14

8-input multiplexer (3-State)

74ALS251

SO16: plastic small outline package; 16 leads; body width 3.9 mm

SOT109-1

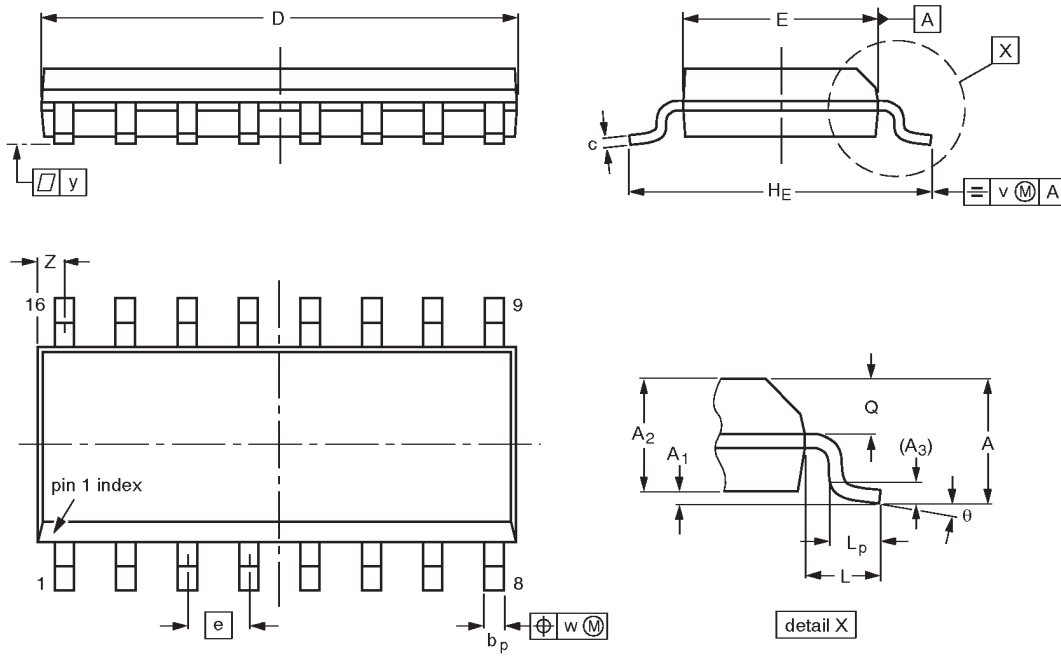

DIMENSIONS (inch dimensions are derived from the original mm dimensions)

UNIT	A max.	A <sub>1</sub>	A <sub>2</sub>	A <sub>3</sub>	b <sub>p</sub>	c	D <sup>(1)</sup>	E <sup>(1)</sup>	e	H <sub>E</sub>	L	L <sub>p</sub>	Q	v	w	y	Z <sup>(1)</sup>	θ
mm	1.75	0.25 0.10	1.45 1.25	0.25	0.49 0.36	0.25 0.19	10.0 9.8	4.0 3.8	1.27	6.2 5.8	1.05	1.0 0.4	0.7 0.6	0.25	0.25	0.1	0.7 0.3	8° 0°
inches	0.069	0.0098 0.0039	0.057 0.049	0.01	0.019 0.014	0.0098 0.0075	0.39 0.38	0.16 0.15	0.050	0.24 0.23	0.041	0.039 0.016	0.028 0.020	0.01	0.01	0.004	0.028 0.012	

Note

1. Plastic or metal protrusions of 0.15 mm maximum per side are not included.

OUTLINE VERSION	REFERENCES				EUROPEAN PROJECTION	ISSUE DATE
	IEC	JEDEC	EIAJ			
SOT109-1	076E07S	MS-012AC				91-08-13 95-01-23

## 8-input multiplexer (3-State)

74ALS251

## DEFINITIONS

Data Sheet Identification	Product Status	Definition
<i>Objective Specification</i>	<b>Formative or in Design</b>	This data sheet contains the design target or goal specifications for product development. Specifications may change in any manner without notice.
<i>Preliminary Specification</i>	<b>Preproduction Product</b>	This data sheet contains preliminary data, and supplementary data will be published at a later date. Philips Semiconductors reserves the right to make changes at any time without notice in order to improve design and supply the best possible product.
<i>Product Specification</i>	<b>Full Production</b>	This data sheet contains Final Specifications. Philips Semiconductors reserves the right to make changes at any time without notice, in order to improve design and supply the best possible product.

Philips Semiconductors and Philips Electronics North America Corporation reserve the right to make changes, without notice, in the products, including circuits, standard cells, and/or software, described or contained herein in order to improve design and/or performance. Philips Semiconductors assumes no responsibility or liability for the use of any of these products, conveys no license or title under any patent, copyright, or mask work right to these products, and makes no representations or warranties that these products are free from patent, copyright, or mask work right infringement, unless otherwise specified. Applications that are described herein for any of these products are for illustrative purposes only. Philips Semiconductors makes no representation or warranty that such applications will be suitable for the specified use without further testing or modification.

## LIFE SUPPORT APPLICATIONS

Philips Semiconductors and Philips Electronics North America Corporation Products are not designed for use in life support appliances, devices, or systems where malfunction of a Philips Semiconductors and Philips Electronics North America Corporation Product can reasonably be expected to result in a personal injury. Philips Semiconductors and Philips Electronics North America Corporation customers using or selling Philips Semiconductors and Philips Electronics North America Corporation Products for use in such applications do so at their own risk and agree to fully indemnify Philips Semiconductors and Philips Electronics North America Corporation for any damages resulting from such improper use or sale.

Philips Semiconductors  
811 East Arques Avenue  
P.O. Box 3409  
Sunnyvale, California 94088-3409  
Telephone 800-234-7381

© Copyright Philips Electronics North America Corporation 1997  
All rights reserved. Printed in U.S.A.

*Let's make things better.*