



# 74LCX16373

## LOW VOLTAGE CMOS 16-BIT D-TYPE LATCH (3-STATE) WITH 5V TOLERANT INPUTS AND OUTPUTS

- 5V TOLERANT INPUTS AND OUTPUTS
- HIGH SPEED :  
 $t_{PD} = 5.4 \text{ ns (MAX.) at } V_{CC} = 3V$
- POWER DOWN PROTECTION ON INPUTS AND OUTPUTS
- SYMMETRICAL OUTPUT IMPEDANCE:  
 $|I_{OH}| = I_{OL} = 24\text{mA (MIN) at } V_{CC} = 3V$
- PCI BUS LEVELS GUARANTEED AT 24 mA
- BALANCED PROPAGATION DELAYS:  
 $t_{PLH} \cong t_{PHL}$
- OPERATING VOLTAGE RANGE:  
 $V_{CC(OPR)} = 2.0V \text{ to } 3.6V \text{ (1.5V Data Retention)}$
- PIN AND FUNCTION COMPATIBLE WITH 74 SERIES 16373
- LATCH-UP PERFORMANCE EXCEEDS 500mA (JESD 17)
- ESD PERFORMANCE:  
 HBM > 2000V (MIL STD 883 method 3015);  
 MM > 200V



### ORDER CODES

PACKAGE	TUBE	T & R
TSSOP		74LCX16373TTR

### PIN CONNECTION

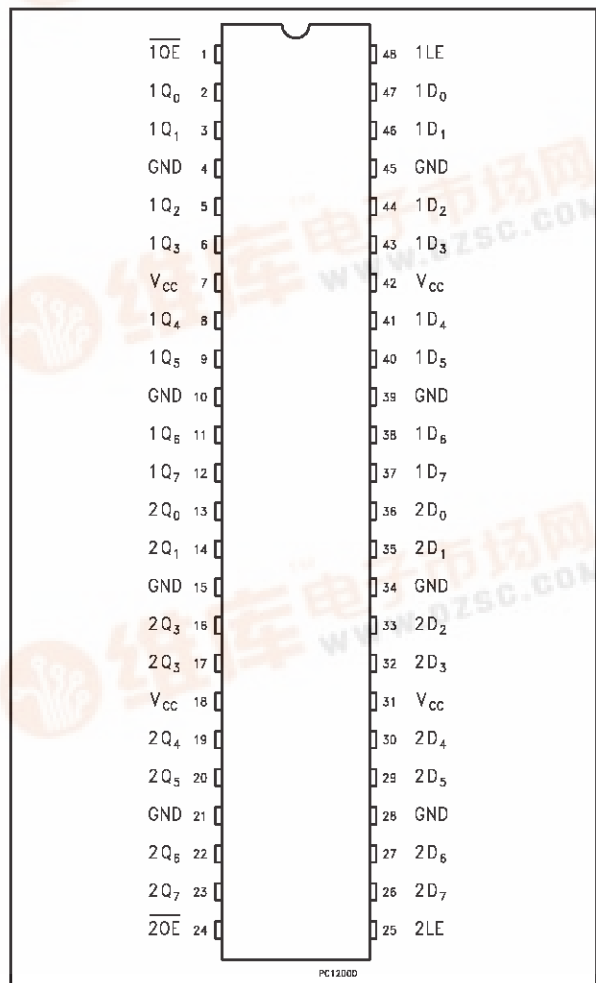

### DESCRIPTION

The 74LCX16373 is a low voltage CMOS 16 BIT D-TYPE LATCH with 3 STATE OUTPUTS NON INVERTING fabricated with sub-micron silicon gate and double-layer metal wiring C<sup>2</sup>MOS technology. It is ideal for low power and high speed 3.3V applications; it can be interfaced to 5V signal environment for both inputs and outputs.

These 16 bit D-TYPE latches are byte controlled by two latch enable inputs (nLE) and two output enable inputs( $\overline{OE}$ ).

While the nLE input is held at a high level, the nQ outputs will follow the data input precisely.

When the nLE is taken LOW, the nQ outputs will be latched precisely at the logic level of D input data.

While the ( $\overline{nOE}$ ) input is low, the nQ outputs will be in a normal logic state (high or low logic level) and while high level the outputs will be in a high impedance state.

It has same speed performance at 3.3V than 5V AC/ACT family, combined with a lower power consumption.

All inputs and outputs are equipped with protection circuits against static discharge, giving them 2KV ESD immunity and transient excess voltage.



INPUT AND OUTPUT EQUIVALENT CIRCUIT

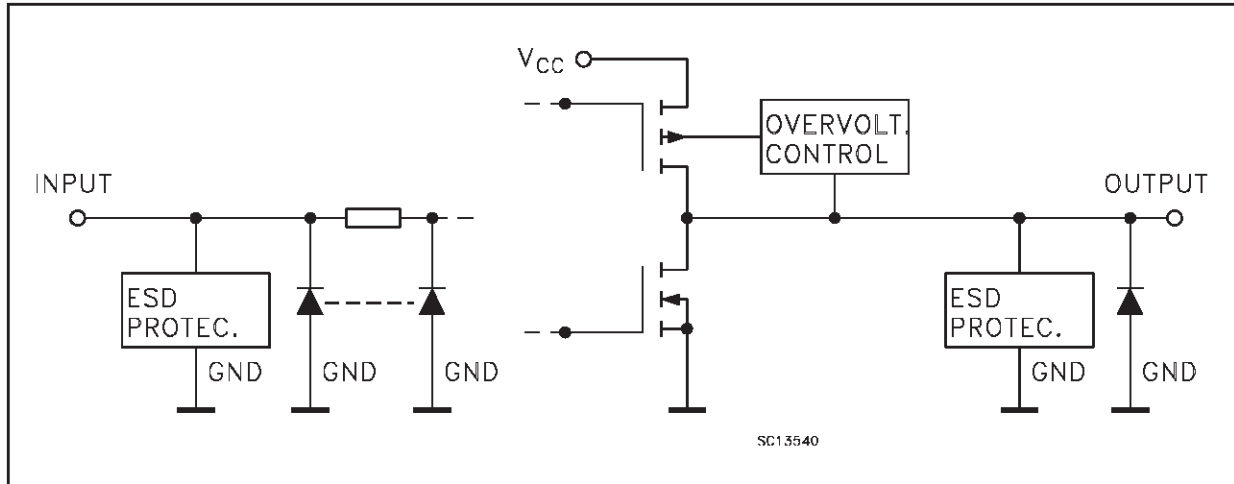

PIN DESCRIPTION

PIN No	SYMBOL	NAME AND FUNCTION
1	1OE	3 State Output Enable Input (Active LOW)
2, 3, 5, 6, 8, 9, 11, 12	1Q0 to 1Q7	3-State Outputs
13, 14, 16, 17, 19, 20, 22, 23	2Q0 to 2Q7	3-State Outputs
24	2OE	3 State Output Enable Input (Active LOW)
25	2LE	Latch Enable Input
36, 35, 33, 32, 30, 29, 27, 26	2D0 to 2D7	Data Inputs
47, 46, 44, 43, 41, 40, 38, 37	1D0 to 1D7	Data Inputs
48	1LE	Latch Enable Input
4, 10, 15, 21, 28, 34, 39, 45	GND	Ground (0V)
7, 18, 31, 42	V <sub>CC</sub>	Positive Supply Voltage

TRUTH TABLE

INPUTS			OUTPUT
OE	LE	D	Q
H	X	X	Z
L	L	X	NO CHANGE *
L	H	L	L
L	H	H	H

X : Don't Care  
 Z : High Impedance  
 \* : Q outputs are latched at the time when the LE input is taken low logic level.

IEC LOGIC SYMBOLS

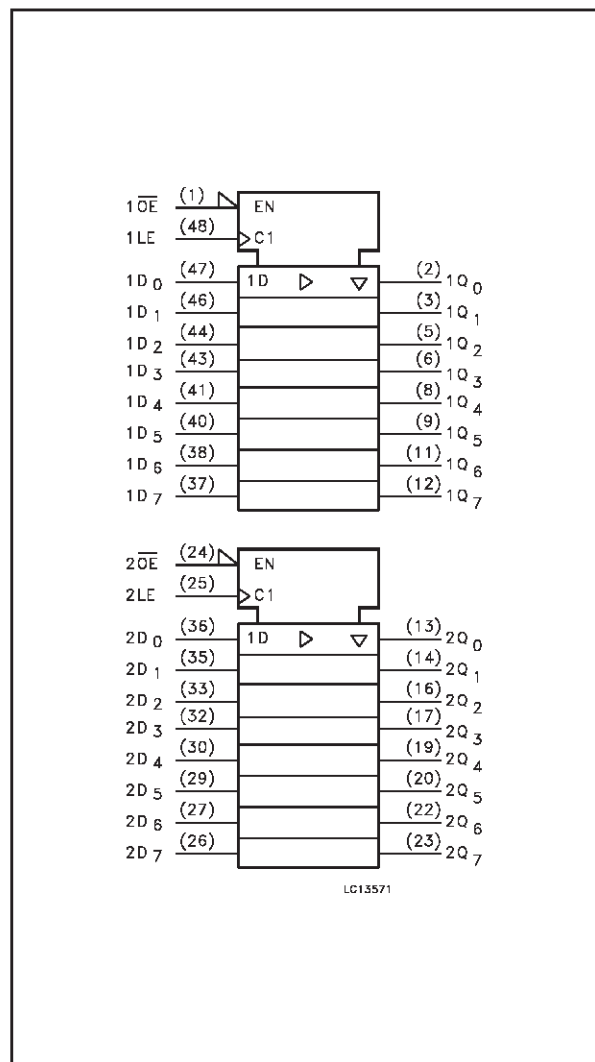

## LOGIC DIAGRAM

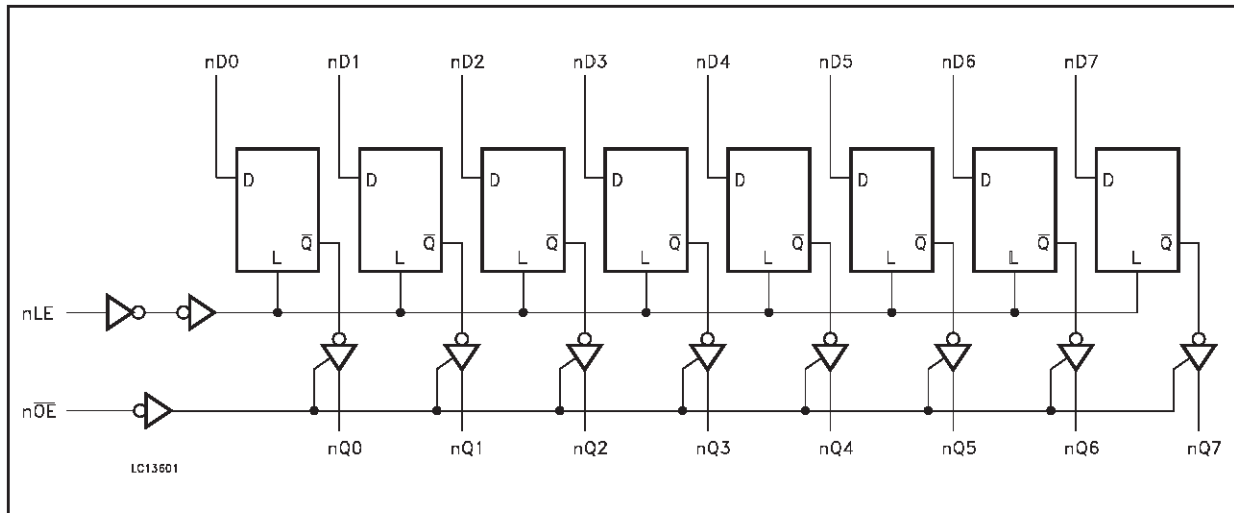

This logic diagram has not to be used to estimate propagation delays

## ABSOLUTE MAXIMUM RATINGS

Symbol	Parameter	Value	Unit
$V_{CC}$	Supply Voltage	-0.5 to +7.0	V
$V_I$	DC Input Voltage	-0.5 to +7.0	V
$V_O$	DC Output Voltage (OFF State)	-0.5 to +7.0	V
$V_O$	DC Output Voltage (High or Low State) (note 1)	-0.5 to $V_{CC} + 0.5$	V
$I_{IK}$	DC Input Diode Current	- 50	mA
$I_{OK}$	DC Output Diode Current (note 2)	- 50	mA
$I_O$	DC Output Current	$\pm 50$	mA
$I_{CC}$	DC Supply Current per Supply Pin	$\pm 100$	mA
$I_{GND}$	DC Ground Current per Supply Pin	$\pm 100$	mA
$T_{stg}$	Storage Temperature	-65 to +150	$^{\circ}C$
$T_L$	Lead Temperature (10 sec)	300	$^{\circ}C$

Absolute Maximum Ratings are those values beyond which damage to the device may occur. Functional operation under these conditions is not implied

- 1)  $I_O$  absolute maximum rating must be observed  
 2)  $V_O < GND$

## RECOMMENDED OPERATING CONDITIONS

Symbol	Parameter	Value	Unit
$V_{CC}$	Supply Voltage (note 1)	2.0 to 3.6	V
$V_I$	Input Voltage	0 to 5.5	V
$V_O$	Output Voltage (OFF State)	0 to 5.5	V
$V_O$	Output Voltage (High or Low State)	0 to $V_{CC}$	V
$I_{OH}, I_{OL}$	High or Low Level Output Current ( $V_{CC} = 3.0$ to $3.6V$ )	$\pm 24$	mA
$I_{OH}, I_{OL}$	High or Low Level Output Current ( $V_{CC} = 2.7V$ )	$\pm 12$	mA
$T_{op}$	Operating Temperature	-55 to 125	$^{\circ}C$
dt/dv	Input Rise and Fall Time (note 2)	0 to 10	ns/V

- 1) Truth Table guaranteed: 1.5V to 3.6V  
 2)  $V_{IN}$  from 0.8V to 2V at  $V_{CC} = 3.0V$

## DC SPECIFICATIONS

Symbol	Parameter	Test Condition		Value				Unit
		V <sub>CC</sub> (V)		-40 to 85 °C		-55 to 125 °C		
				Min.	Max.	Min.	Max.	
V <sub>IH</sub>	High Level Input Voltage	2.7 to 3.6		2.0		2.0		V
V <sub>IL</sub>	Low Level Input Voltage					0.8		0.8
V <sub>OH</sub>	High Level Output Voltage	2.7 to 3.6	I <sub>O</sub> =-100 μA	V <sub>CC</sub> -0.2		V <sub>CC</sub> -0.2		V
		2.7	I <sub>O</sub> =-12 mA	2.2		2.2		
		3.0	I <sub>O</sub> =-18 mA	2.4		2.4		
			I <sub>O</sub> =-24 mA	2.2		2.2		
V <sub>OL</sub>	Low Level Output Voltage	2.7 to 3.6	I <sub>O</sub> =100 μA		0.2		0.2	V
		2.7	I <sub>O</sub> =12 mA		0.4		0.4	
		3.0	I <sub>O</sub> =16 mA		0.4		0.4	
			I <sub>O</sub> =24 mA		0.55		0.55	
I <sub>I</sub>	Input Leakage Current	2.7 to 3.6	V <sub>I</sub> = 0 to 5.5V		± 5		± 5	μA
I <sub>off</sub>	Power Off Leakage Current	0	V <sub>I</sub> or V <sub>O</sub> = 5.5V		10		10	μA
I <sub>OZ</sub>	High Impedance Output Leakage Current	2.7 to 3.6	V <sub>I</sub> = V <sub>IH</sub> or V <sub>IL</sub> V <sub>O</sub> = 0 to V <sub>CC</sub>		± 5		± 5	μA
I <sub>CC</sub>	Quiescent Supply Current	2.7 to 3.6	V <sub>I</sub> = V <sub>CC</sub> or GND		20		20	μA
			V <sub>I</sub> or V <sub>O</sub> = 3.6 to 5.5V		± 20		± 20	
ΔI <sub>CC</sub>	I <sub>CC</sub> incr. per Input	2.7 to 3.6	V <sub>IH</sub> = V <sub>CC</sub> - 0.6V		500		500	μA

## DYNAMIC SWITCHING CHARACTERISTICS

Symbol	Parameter	Test Condition		Value			Unit
		V <sub>CC</sub> (V)		T <sub>A</sub> = 25 °C			
				Min.	Typ.	Max.	
V <sub>OLP</sub>	Dynamic Low Level Quiet Output (note 1)	3.3	C <sub>L</sub> = 50pF V <sub>IL</sub> = 0V, V <sub>IH</sub> = 3.3V		0.8		V
V <sub>OLV</sub>					-0.8		

1) Number of outputs defined as "n". Measured with "n-1" outputs switching from HIGH to LOW or LOW to HIGH. The remaining output is measured in the LOW state.

## AC ELECTRICAL CHARACTERISTICS

Symbol	Parameter	Test Condition				Value				Unit
		V <sub>CC</sub> (V)	C <sub>L</sub> (pF)	R <sub>L</sub> (Ω)	t <sub>s</sub> = t <sub>r</sub> (ns)	-40 to 85 °C		-55 to 125 °C		
						Min.	Max.	Min.	Max.	
t <sub>PLH</sub> t <sub>PHL</sub>	Propagation Delay Time (Dn to Qn)	2.7	50	500	2.5	1.5	5.9	1.5	5.9	ns
		3.0 to 3.6				1.5	5.4	1.5	5.4	
t <sub>PLH</sub> t <sub>PHL</sub>	Propagation Delay Time (LE to Qn)	2.7	50	500	2.5	1.5	6.4	1.5	6.4	ns
		3.0 to 3.6				1.5	5.5	1.5	5.5	
t <sub>PZL</sub> t <sub>PZH</sub>	Output Enable Time to HIGH and LOW level	2.7	50	500	2.5	1.5	6.5	1.5	6.5	ns
		3.0 to 3.6				1.5	6.1	1.5	6.1	
t <sub>PLZ</sub> t <sub>PHZ</sub>	Output Disable Time from HIGH to LOW level	2.7	50	500	2.5	1.5	6.3	1.5	6.3	ns
		3.0 to 3.6				1.5	6.0	1.5	6.0	
t <sub>S</sub>	Set-Up Time, HIGH or LOW level (Dn to LE)	2.7	50	500	2.5	2.5		2.5		ns
		3.0 to 3.6				2.5		2.5		
t <sub>H</sub>	Hold Time, HIGH or LOW level (Dn to LE)	2.7	50	500	2.5	1.5		1.5		ns
		3.0 to 3.6				1.5		1.5		
t <sub>W</sub>	LE Pulse Width, HIGH	2.7	50	500	2.5	3.0		3.0		ns
		3.0 to 3.6				3.0		3.0		
t <sub>OSLH</sub> t <sub>OSHL</sub>	Output To Output Skew Time (note1, 2)	3.0 to 3.6	50	500	2.5		1.0		1.0	ns

1) Skew is defined as the absolute value of the difference between the actual propagation delay for any two outputs of the same device switching in the same direction, either HIGH or LOW (t<sub>OSLH</sub> = |t<sub>PLHm</sub> - t<sub>PLHn</sub>|, t<sub>OSHL</sub> = |t<sub>PHLm</sub> - t<sub>PHLn</sub>|)

2) Parameter guaranteed by design

## CAPACITIVE CHARACTERISTICS

Symbol	Parameter	Test Condition		Value			Unit
		V <sub>CC</sub> (V)		T <sub>A</sub> = 25 °C			
				Min.	Typ.	Max.	
C <sub>IN</sub>	Input Capacitance	3.3	V <sub>IN</sub> = 0 to V <sub>CC</sub>		7		pF
C <sub>OUT</sub>	Output Capacitance	3.3	V <sub>IN</sub> = 0 to V <sub>CC</sub>		8		pF
C <sub>PD</sub>	Power Dissipation Capacitance (note 1)	3.3	f <sub>IN</sub> = 10MHz V <sub>IN</sub> = 0 or V <sub>CC</sub>		20		pF

1) C<sub>PD</sub> is defined as the value of the IC's internal equivalent capacitance which is calculated from the operating current consumption without load. (Refer to Test Circuit). Average operating current can be obtained by the following equation. I<sub>CC(opr)</sub> = C<sub>PD</sub> × V<sub>CC</sub> × f<sub>IN</sub> + I<sub>CC</sub>/16 (per circuit)

TEST CIRCUIT

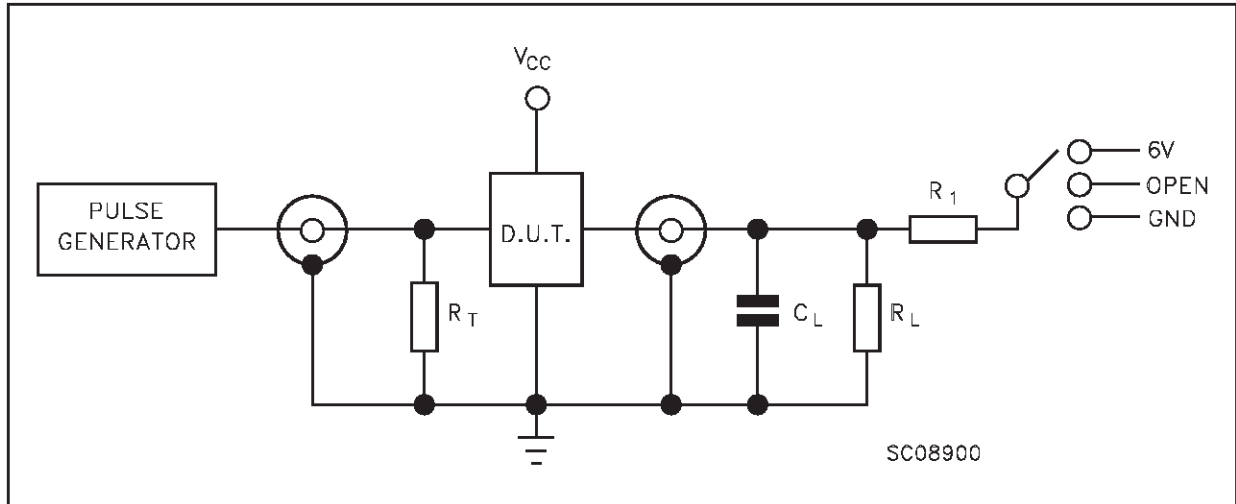

TEST	SWITCH
$t_{PLH}$ , $t_{PHL}$	Open
$t_{PZL}$ , $t_{PLZ}$	6V
$t_{PZH}$ , $t_{PHZ}$	GND

$C_L$  = 50 pF or equivalent (includes jig and probe capacitance)  
 $R_L$  =  $R_1$  = 500 $\Omega$  or equivalent  
 $R_T$  =  $Z_{OUT}$  of pulse generator (typically 50 $\Omega$ )

**WAVEFORM 1 : LE TO Qn PROPAGATION DELAYS, LE MINIMUM PULSE WIDTH, Dn TO LE SETUP AND HOLD TIMES (f=1MHz; 50% duty cycle)**

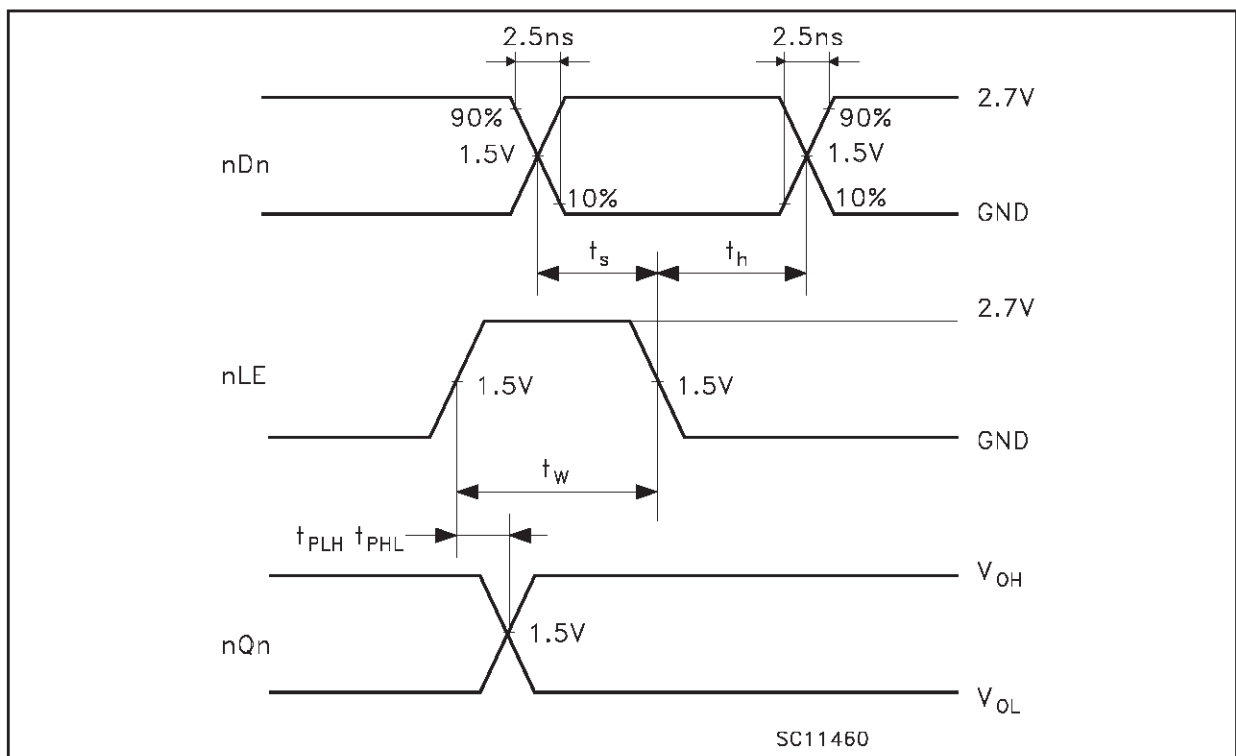

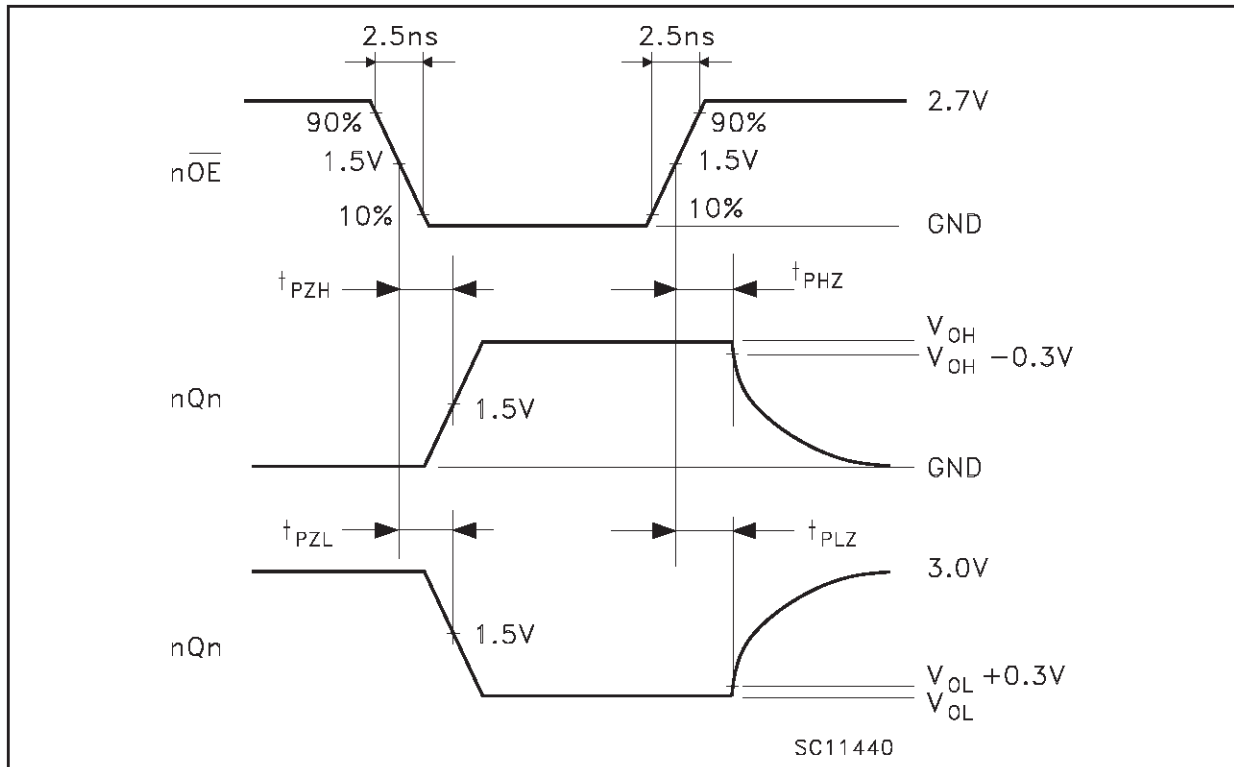
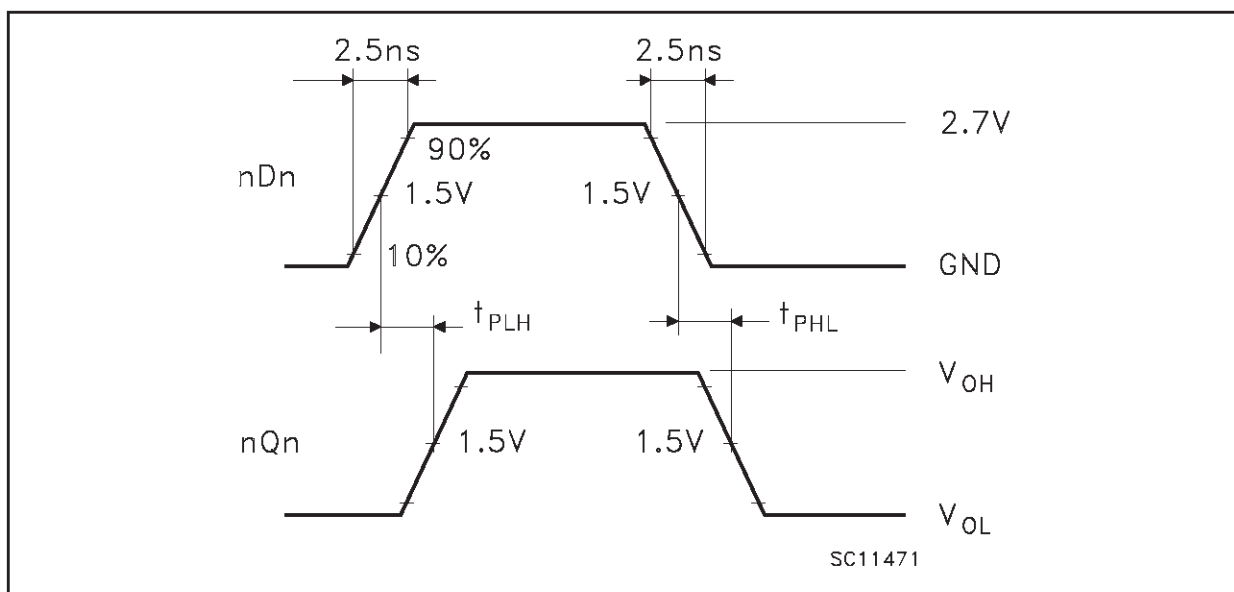
**WAVEFORM 2 : OUTPUT ENABLE AND DISABLE TIME (f=1MHz; 50% duty cycle)****WAVEFORM 3 : PROPAGATION DELAY TIME (f=1MHz; 50% duty cycle)**

## TSSOP48 MECHANICAL DATA

DIM.	mm.			inch		
	MIN.	TYP	MAX.	MIN.	TYP.	MAX.
A			1.1			0.043
A1	0.05		0.15	0.002		0.006
A2		0.9			0.035	
b	0.17		0.27	0.0067		0.011
c	0.09		0.20	0.0035		0.0079
D	12.4		12.6	0.408		0.496
E	7.95		8.25	0.313		0.325
E1	6.0		6.2	0.236		0.244
e		0.5 BSC			0.0197 BSC	
K	0°		8°	0°		8°
L	0.50		0.75	0.020		0.030

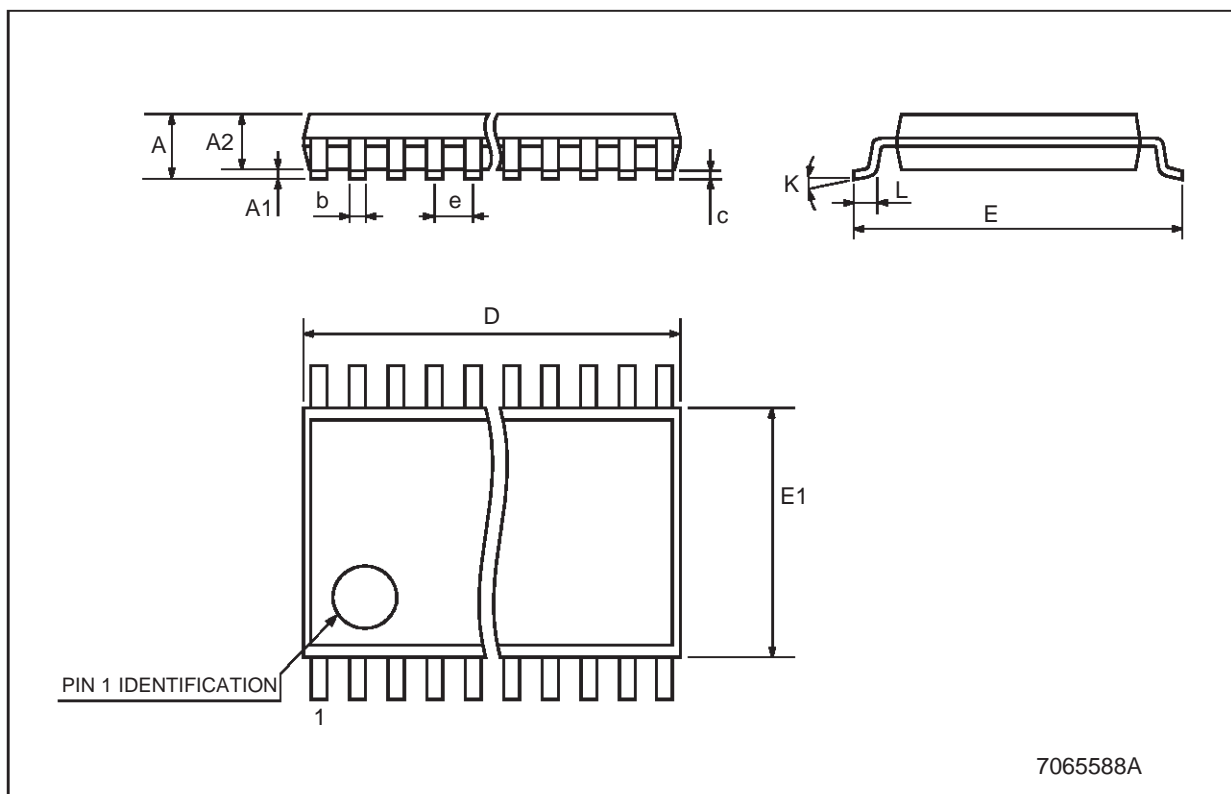

7065588A



Information furnished is believed to be accurate and reliable. However, STMicroelectronics assumes no responsibility for the consequences of use of such information nor for any infringement of patents or other rights of third parties which may result from its use. No license is granted by implication or otherwise under any patent or patent rights of STMicroelectronics. Specifications mentioned in this publication are subject to change without notice. This publication supersedes and replaces all information previously supplied. STMicroelectronics products are not authorized for use as critical components in life support devices or systems without express written approval of STMicroelectronics.

© The ST logo is a registered trademark of STMicroelectronics

© 2001 STMicroelectronics - Printed in Italy - All Rights Reserved  
STMicroelectronics GROUP OF COMPANIES

Australia - Brazil - China - Finland - France - Germany - Hong Kong - India - Italy - Japan - Malaysia - Malta - Morocco  
Singapore - Spain - Sweden - Switzerland - United Kingdom

© <http://www.st.com>

