

FAIRCHILD
SEMICONDUCTOR™

August 1986
Revised March 2000

DM74LS279 Quad \bar{S} -R Latch

General Description

The DM74LS279 consists of four individual and independent Set-Reset Latches with active low inputs. Two of the four latches have an additional \bar{S} input ANDed with the primary \bar{S} input. A LOW on any \bar{S} input while the \bar{R} input is HIGH will be stored in the latch and appear on the corresponding Q output as a HIGH. A LOW on the \bar{R} input while the \bar{S} input is HIGH will clear the Q output to a LOW. Simultaneous transition of the \bar{R} and \bar{S} inputs from LOW-to-HIGH will cause the Q output to be indeterminate. Both inputs are voltage level triggered and are not affected by transition time of the input data.

Ordering Code:

| Order Number | Package Number | Package Description |
|--------------|----------------|---|
| DM74LS279M | M16A | 16-Lead Small Outline Integrated Circuit (SOIC), JEDEC MS-012, 0.150 Narrow |
| DM74LS279N | N16E | 16-Lead Plastic Dual-In-Line Package (PDIP), JEDEC MS-001, 0.300 Wide |

Devices also available in Tape and Reel. Specify by appending the suffix letter "X" to the ordering code.

Connection Diagram

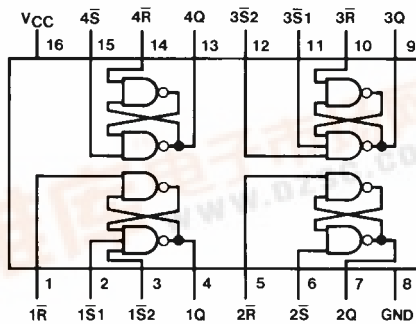

Function Table

| Inputs | | Output |
|--------------------|-----------|------------|
| \bar{S} (Note 1) | \bar{R} | Q |
| L | L | H (Note 2) |
| L | H | H |
| H | L | L |
| H | H | Q_0 |

H = HIGH Level

L = LOW Level

Q_0 = The Level of Q before the indicated input conditions were established.

Note 1: For latches with double \bar{S} inputs:

H = both \bar{S} inputs HIGH

L = one or both \bar{S} inputs LOW

Note 2: This output level is pseudo stable; that is, it may not persist when the \bar{S} and \bar{R} inputs return to their inactive (HIGH) level.

DM74LS279 Quad S-R Latch



Absolute Maximum Ratings (Note 3)

| | |
|--------------------------------------|-----------------|
| Supply Voltage | 7V |
| Input Voltage | 7V |
| Operating Free Air Temperature Range | 0°C to +70°C |
| Storage Temperature Range | -65°C to +150°C |

Note 3: The "Absolute Maximum Ratings" are those values beyond which the safety of the device cannot be guaranteed. The device should not be operated at these limits. The parametric values defined in the Electrical Characteristics tables are not guaranteed at the absolute maximum ratings. The "Recommended Operating Conditions" table will define the conditions for actual device operation.

Recommended Operating Conditions

| Symbol | Parameter | Min | Nom | Max | Units |
|-----------------|--------------------------------|------|-----|------|-------|
| V _{CC} | Supply Voltage | 4.75 | 5 | 5.25 | V |
| V _{IH} | HIGH Level Input Voltage | 2 | | | V |
| V _{IL} | LOW Level Input Voltage | | | 0.8 | V |
| I _{OH} | HIGH Level Output Current | | | -0.4 | mA |
| I _{OL} | LOW Level Output Current | | | 8 | mA |
| T _A | Free Air Operating Temperature | 0 | | 70 | °C |

Electrical Characteristics

over recommended operating free air temperature range (unless otherwise noted)

| Symbol | Parameter | Conditions | Min | Typ (Note 4) | Max | Units |
|-----------------|-----------------------------------|---|-----|-----------------|------------|-------|
| V _I | Input Clamp Voltage | V _{CC} = Min, I _I = -18 mA | | | -1.5 | V |
| V _{OH} | HIGH Level Output Voltage | V _{CC} = Min, I _{OH} = Max V _{IL} = Max, V _{IH} = Min | 2.7 | 3.5 | | V |
| V _{OL} | LOW Level Output Voltage | V _{CC} = Min, I _{OL} = Max V _{IL} = Max, V _{IH} = Min I _{OL} = 4 mA, V _{CC} = Min | | 0.35 0.25 | 0.5 0.4 | V |
| I _I | Input Current @ Max Input Voltage | V _{CC} = Max, V _I = 7V | | | 0.1 | mA |
| I _{IH} | HIGH Level Input Current | V _{CC} = Max, V _I = 2.7V | | | 20 | μA |
| I _{IL} | LOW Level Input Current | V _{CC} = Max, V _I = 0.4V | | | -0.4 | mA |
| I _{OS} | Short Circuit Output Current | V _{CC} = Max (Note 5) | -20 | | -100 | mA |
| I _{CC} | Supply Current | V _{CC} = Max (Note 6) | | 3.8 | 7 | mA |

Note 4: All typicals are at V_{CC} = 5V, T_A = 25°C.

Note 5: Not more than one output should be shorted at a time, and the duration should not exceed one second.

Note 6: I_{CC} is measured with all \bar{R} inputs grounded, all \bar{S} inputs at 4.5V and all outputs OPEN.

Switching Characteristics

at V_{CC} = 5V and T_A = 25°C

| Symbol | Parameter | From (Input) To (Output) | R _L = 2 kΩ | | | | Units |
|------------------|--|-----------------------------|------------------------|-----|------------------------|-----|-------|
| | | | C _L = 15 pF | | C _L = 50 pF | | |
| | | | Min | Max | Min | Max | |
| t _{PLH} | Propagation Delay Time LOW-to-HIGH Level Output | \bar{S} to Q | | 22 | | 25 | ns |
| t _{PHL} | Propagation Delay Time HIGH-to-LOW Level Output | \bar{S} to Q | | 15 | | 23 | ns |
| t _{PHL} | Propagation Delay Time HIGH-to-LOW Level Output | \bar{R} to Q | | 27 | | 33 | ns |

Physical Dimensions inches (millimeters) unless otherwise noted

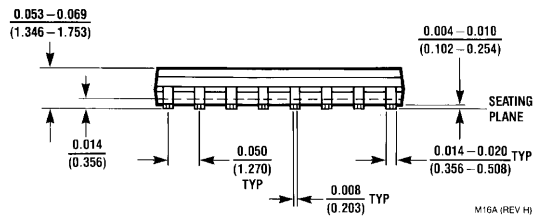
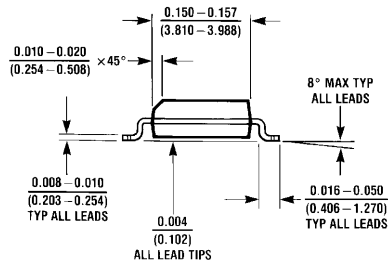
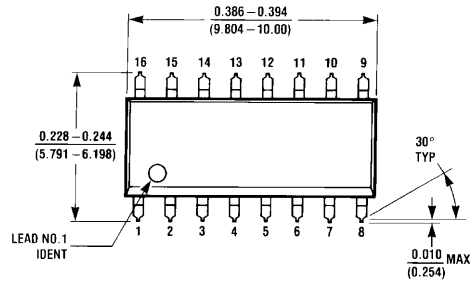

**16-Lead Small Outline Integrated Circuit (SOIC), JEDEC MS-012, 0.150 Narrow
Package Number M16A**

Physical Dimensions inches (millimeters) unless otherwise noted (Continued)

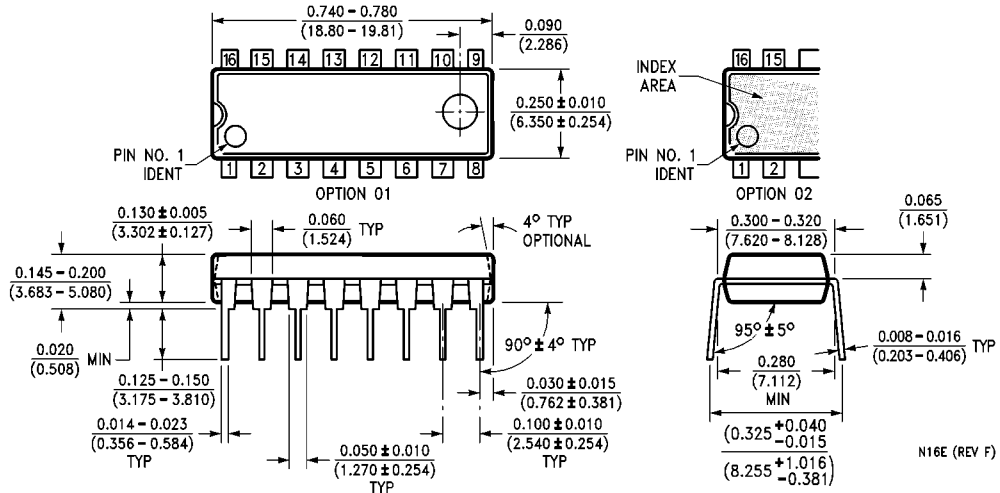

16-Lead Plastic Dual-In-Line Package (PDIP), JEDEC MS-001, 0.300 Wide Package Number N16E

Fairchild does not assume any responsibility for use of any circuitry described, no circuit patent licenses are implied and Fairchild reserves the right at any time without notice to change said circuitry and specifications.

LIFE SUPPORT POLICY

FAIRCHILD'S PRODUCTS ARE NOT AUTHORIZED FOR USE AS CRITICAL COMPONENTS IN LIFE SUPPORT DEVICES OR SYSTEMS WITHOUT THE EXPRESS WRITTEN APPROVAL OF THE PRESIDENT OF FAIRCHILD SEMICONDUCTOR CORPORATION. As used herein:

1. Life support devices or systems are devices or systems which, (a) are intended for surgical implant into the body, or (b) support or sustain life, and (c) whose failure to perform when properly used in accordance with instructions for use provided in the labeling, can be reasonably expected to result in a significant injury to the user.
2. A critical component in any component of a life support device or system whose failure to perform can be reasonably expected to cause the failure of the life support device or system, or to affect its safety or effectiveness.

www.fairchildsemi.com