

INTEGRATED CIRCUITS

DATA SHEET

74LV165A

8-bit parallel-in/serial-out shift register

Product specification

2003 Jul 23

Philips
Semiconductors



PHILIPS



8-bit parallel-in/serial-out shift register

74LV165A

FEATURES

- Wide supply voltage range from 2.0 to 5.5 V
- Complies with JEDEC standard:
JESD8-5 (2.3 to 2.7 V)
JESD8B/JESD36 (2.7 to 3.6 V)
JESD8-1A (4.5 to 5.5 V).
- 5.5 V tolerant inputs/outputs
- CMOS LOW power consumption
- Direct interface with TTL levels (2.7 to 3.6 V)
- Power-down mode
- Asynchronous 8-bit parallel load
- Synchronous serial input
- Latch-up performance exceeds 250 mA
- ESD protection:
HBM EIA/JESD22-A114-A exceeds 2000 V
MM EIA/JESD22-A115-A exceeds 200 V.

DESCRIPTION

The 74LV165A is a high-performance, low-power, low-voltage, Is-gate CMOS device and superior to most advanced CMOS compatible TTL families.

QUICK REFERENCE DATA

GND = 0 V; T_{amb} = 25 °C.

SYMBOL	PARAMETER	CONDITIONS	TYPICAL	UNIT
t _{PHL} /t _{PLH}	propagation delay \overline{CE} , CP to Q7, $\overline{Q7}$ \overline{PL} to Q7, $\overline{Q7}$ D7 to Q7, $\overline{Q7}$	V _{CC} = 3.3 V; C _L = 15 pF	7.5 8.0 8.5	ns ns ns
f _{max}	maximum clock frequency	V _{CC} = 3.3 V; C _L = 15 pF	115	MHz
C _I	input capacitance		3.0	pF
C _{PD}	power dissipation capacitance per buffer	V _{CC} = 3.3 V; notes 1 and 2	24	pF

Notes

1. C_{PD} is used to determine the dynamic power dissipation (P_D in μW).
 $P_D = C_{PD} \times V_{CC}^2 \times f_i \times N + \Sigma(C_L \times V_{CC}^2 \times f_o)$ where:
f_i = input frequency in MHz;
f_o = output frequency in MHz;
C_L = output load capacitance in pF;
V_{CC} = supply voltage in Volts;
N = total load switching outputs;
 $\Sigma(C_L \times V_{CC}^2 \times f_o)$ = sum of the outputs.
2. The condition is V_i = GND to V_{CC}.

Schmitt-trigger action at all inputs makes the circuit tolerant for slower input rise and fall times.

This device is fully specified for partial-power-down applications using I_{off}. The I_{off} circuitry disables the output, preventing the damaging current back flow through the device when it is powered down.

The 74LV165A is an 8-bit parallel-load or serial-in shift register with complementary serial outputs (Q7 and $\overline{Q7}$) available from the last stage. When the parallel-load input (\overline{PL}) is LOW, parallel data from the inputs D0 to D7 are loaded into the register asynchronously. When input \overline{PL} is HIGH, data enters the register serially at the input DS and shifts one place to the right (Q0→Q1→Q2, etc.) with each positive-going clock transition. This feature allows parallel-to-serial converter expansion by tying the output Q7 to the input DS of the succeeding stage.

The clock input is a gate-OR structure which allows one input to be used as an active LOW clock enable input (\overline{CE}) input. The pin assignment for the inputs CP and \overline{CE} is arbitrary and can be reversed for layout convenience. The LOW-to-HIGH transition of the input \overline{CE} should only take place while CP HIGH for predictable operation.

8-bit parallel-in/serial-out shift register

74LV165A

ORDERING INFORMATION

TYPE NUMBER	PACKAGES			
	PINS	PACKAGE	MATERIAL	CODE
74LV165AD	16	SO16	plastic	SOT109-1
74LV165APW	16	TSSOP16	plastic	SOT403-1

FUNCTION TABLE

See note 1.

OPERATING MODES	INPUT					ON REGISTER		OUTPUT	
	$\overline{\text{PL}}$	$\overline{\text{CE}}$	CP	DS	D0 to D7	Q0	Q1 to Q6	Q7	$\overline{\text{Q7}}$
Parallel load	L	X	X	X	L	L	L–L	L	H
	L	X	X	X	H	H	H–H	H	L
Serial shift	H	L	↑	l	X	L	q0–q5	q6	$\overline{\text{q6}}$
	H	L	↑	h	X	H	q0–q5	q6	$\overline{\text{q6}}$
Serial shift	H	↑	L	l	X	L	q0–q5	q6	$\overline{\text{q6}}$
	H	↑	L	h	X	H	q0–q5	q6	$\overline{\text{q6}}$
Hold “do nothing”	H	H	X	X	X	q0	q1–q6	q7	$\overline{\text{q7}}$
Hold “do nothing”	H	X	H	X	X	q0	q1–q6	q7	$\overline{\text{q7}}$

Note

- H = HIGH voltage level;
h = HIGH voltage level one set-up time prior to the LOW-to-HIGH clock transition;
L = LOW voltage level;
l = LOW voltage level one set-up time prior to the LOW-to-HIGH clock transition;
q = state of the referenced output one set-up time prior to the LOW-to-HIGH clock transition;
X = don't care;
↑ = LOW-to-HIGH clock transition.

8-bit parallel-in/serial-out shift register

74LV165A

PINNING

PIN	SYMBOL	DESCRIPTION
1	\overline{PL}	asynchronous parallel load input (active LOW)
2	CP	clock input (LOW-to-HIGH, edge-triggered)
3	D4	parallel data input
4	D5	parallel data input
5	D6	parallel data input
6	D7	parallel data input
7	$\overline{Q7}$	complementary serial output from the last stage
8	GND	ground (0 V)
9	Q7	serial output from the last stage
10	DS	serial data input
11	D0	parallel data input
12	D1	parallel data input
13	D2	parallel data input
14	D3	parallel data input
15	\overline{CE}	clock enable input (active LOW)
16	V _{CC}	supply voltage

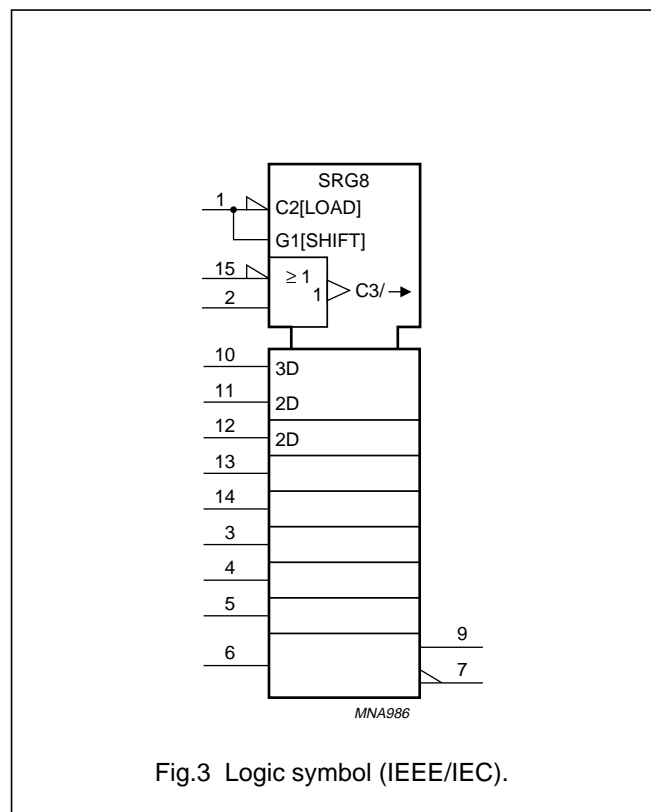
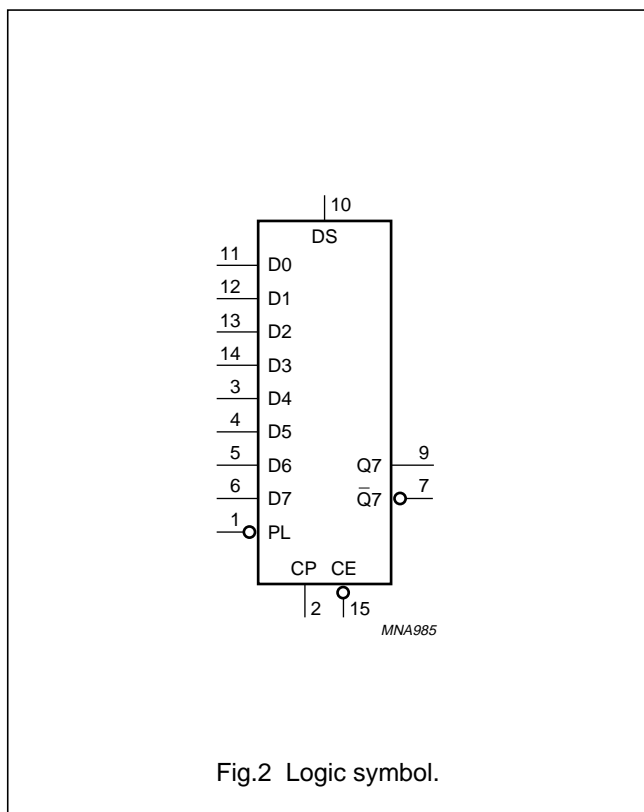
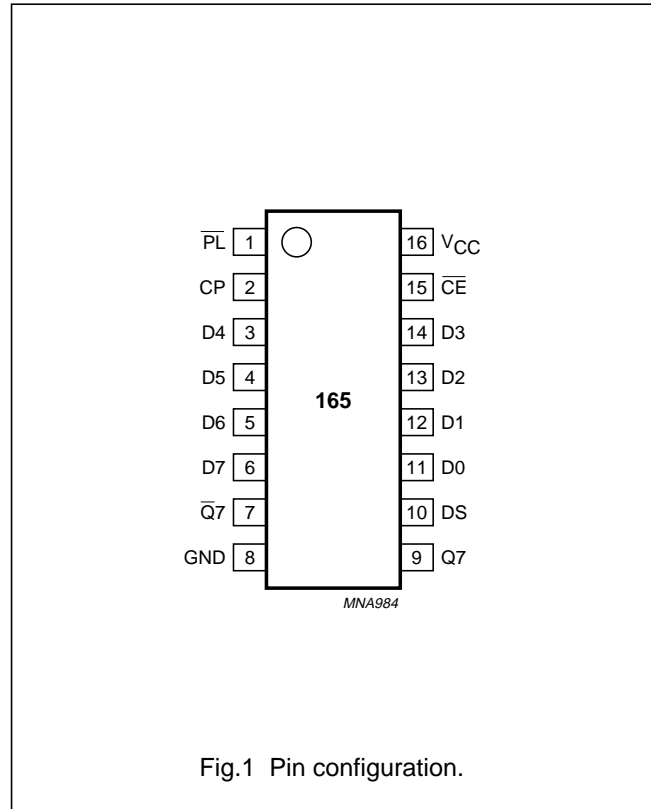

8-bit parallel-in/serial-out shift register

74LV165A

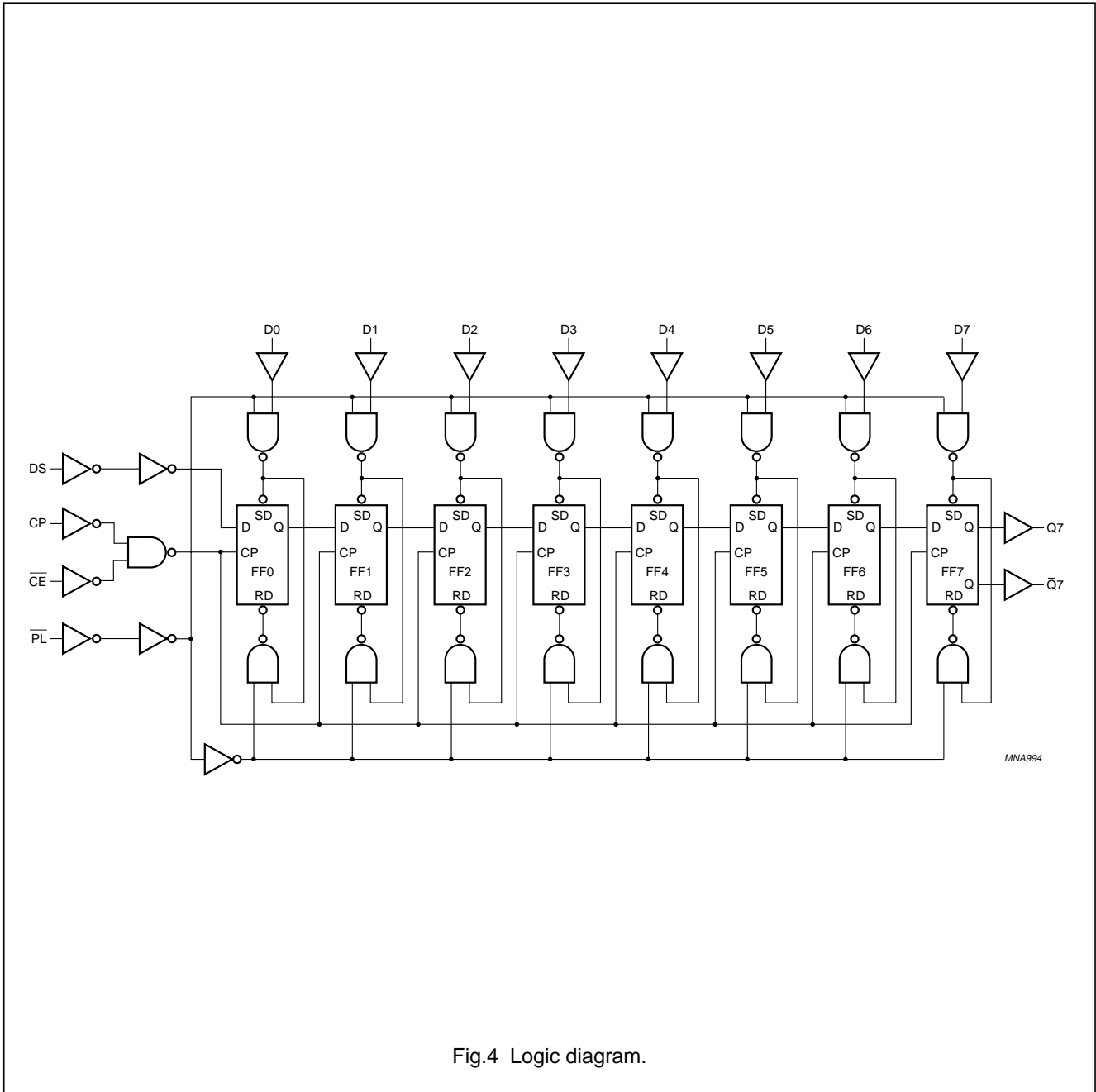

8-bit parallel-in/serial-out shift register

74LV165A

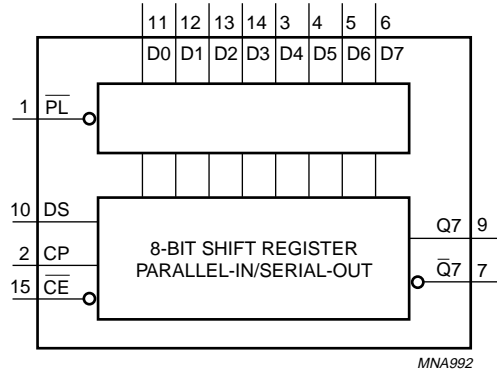

Fig.5 IEC logic symbol.

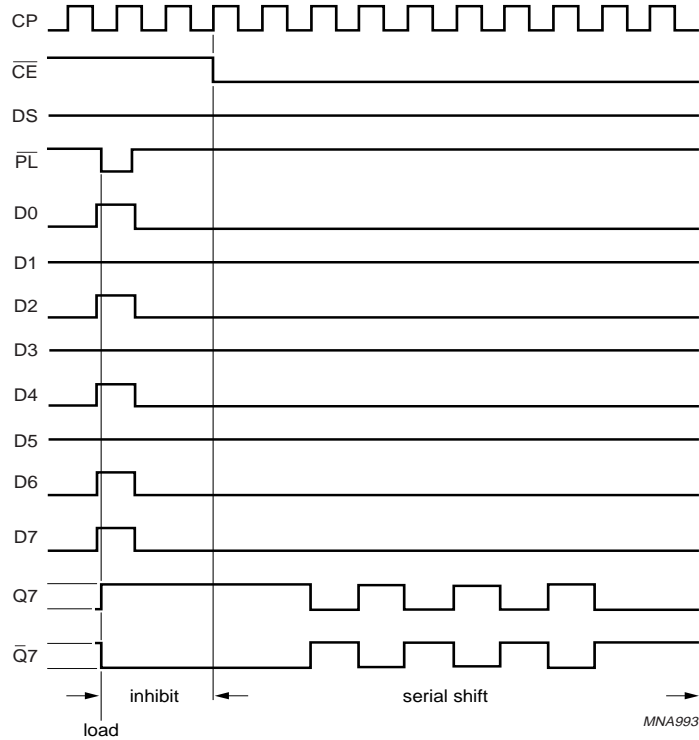

Fig.6 Timing diagram.

8-bit parallel-in/serial-out shift register

74LV165A

RECOMMENDED OPERATING CONDITIONS

SYMBOL	PARAMETER	CONDITIONS	MIN.	MAX.	UNIT
V_{CC}	supply voltage		2.0	5.5	V
V_I	input voltage		0	5.5	V
V_O	output voltage		0	V_{CC}	V
T_{amb}	operating ambient temperature		-40	+85	°C
t_r, t_f	input rise and fall times	$V_{CC} = 2.3$ to 2.7 V	0	200	ns/V
		$V_{CC} = 3.0$ to 3.6 V	0	100	ns/V
		$V_{CC} = 4.5$ to 5.5 V	0	20	ns/V

LIMITING VALUES

In accordance with the Absolute Maximum Rating System (IEC 60134); voltages are referenced to GND (ground = 0 V).

SYMBOL	PARAMETER	CONDITIONS	MIN.	MAX.	UNIT
V_{CC}	supply voltage		-0.5	+7.0	V
I_{IK}	input diode current	$V_I < 0$	-	-20	mA
V_I	input voltage		-0.5	+7.0	V
I_{OK}	output diode current	$V_O > V_{CC}$ or $V_O < 0$	-	±50	mA
V_O	output voltage	note 1	-0.5	$V_{CC} + 0.5$	V
		Power-down mode	-0.5	+7.0	V
I_O	output source or sink current	$V_O = 0$ to V_{CC}	-	±25	mA
I_{CC}, I_{GND}	V_{CC} or GND current		-	±50	mA
T_{stg}	storage temperature		-65	+150	°C
P_{tot}	power dissipation	$T_{amb} = -40$ to $+85$ °C; note 2	-	500	mW

Notes

1. The input and output voltage ratings may be exceeded if the input and output current ratings are observed.
2. For SO16 packages: above 70 °C derate linearly with 8 mW/K.
For TSSOP16 packages: above 60 °C derate linearly with 5.5 mW/K.

8-bit parallel-in/serial-out shift register

74LV165A

DC CHARACTERISTICS

At recommended operating conditions; voltages are referenced to GND (ground = 0 V).

SYMBOL	PARAMETER	TEST CONDITIONS		MIN.	TYP. ⁽¹⁾	MAX.	UNIT
		OTHER	V _{CC} (V)				
T_{amb} = -40 to +85 °C							
V _{IH}	HIGH-level input voltage		2.0	1.5	–	–	V
			2.3 to 2.7	0.7 × V _{CC}	–	–	V
			3.0 to 3.6	0.7 × V _{CC}	–	–	V
			4.5 to 5.5	0.7 × V _{CC}	–	–	V
V _{IL}	LOW-level input voltage		2.0	–	–	0.5	V
			2.3 to 2.7	–	–	0.3 × V _{CC}	V
			3.0 to 3.6	–	–	0.3 × V _{CC}	V
			4.5 to 5.5	–	–	0.3 × V _{CC}	V
V _{OL}	LOW-level output voltage	V _I = V _{IH} or V _{IL} I _O = 50 μA	2.0 to 5.5	–	–	0.1	V
		I _O = 2 mA	2.3	–	–	0.4	V
		I _O = 6 mA	3.0	–	–	0.44	V
		I _O = 12 mA	4.5	–	–	0.55	V
V _{OH}	HIGH-level output voltage	V _I = V _{IH} or V _{IL} I _O = -50 μA	2.0 to 5.5	V _{CC} - 0.1	–	–	V
		I _O = -2 mA	2.3	2.0	–	–	V
		I _O = -6 mA	3.0	2.48	–	–	V
		I _O = -12 mA	4.5	3.8	–	–	V
I _{LI}	input leakage current	V _I = 5.5 V or GND	5.5	–	±0.01	±1	μA
I _{off}	power OFF leakage current	V _I or V _O = 5.5 V	0.0	–	±0.05	±5	μA
I _{CC}	quiescent supply current	V _I = V _{CC} or GND; I _O = 0	5.5	–	0.2	20	μA

Note

1. All typical values are measured at V_{CC} = 5.5 V and T_{amb} = 25 °C.

8-bit parallel-in/serial-out shift register

74LV165A

AC CHARACTERISTICSGND = 0 V; $t_r = t_f \leq 3.0$ ns.

SYMBOL	PARAMETER	TEST CONDITIONS			MIN.	TYP. ⁽¹⁾	MAX.	UNIT
		WAVEFORMS	V _{CC} (V)	C _L (pF)				
T_{amb} = -40 to +85 °C								
t _{PLH} /t _{PHL}	propagation delay CE, CP to Q7, $\overline{Q7}$	see Figs 7, 8 and 12	2.3 to 2.7	15	1.0	11.0	22.0	ns
			3.0 to 3.6	15	1.0	7.5	18.0	ns
			4.5 to 5.5	15	1.0	5.5	11.5	ns
t _{PLH} /t _{PHL}	propagation delay \overline{PL} to Q7, $\overline{Q7}$	see Figs 7, 8 and 12	2.3 to 2.7	15	1.0	11.5	23.5	ns
			3.0 to 3.6	15	1.0	8.0	18.5	ns
			4.5 to 5.5	15	1.0	5.5	11.5	ns
t _{PLH} /t _{PHL}	propagation delay D7 to Q7, $\overline{Q7}$	see Figs 9 and 12	2.3 to 2.7	15	1.0	12.0	24.0	ns
			3.0 to 3.6	15	1.0	8.5	16.5	ns
			4.5 to 5.5	15	1.0	6.0	10.5	ns
t _{PLH} /t _{PHL}	propagation delay CE, CP to Q7, $\overline{Q7}$	see Figs 7, 8 and 12	2.3 to 2.7	50	1.0	13.0	26.0	ns
			3.0 to 3.6	50	1.0	9.0	21.5	ns
			4.5 to 5.5	50	1.0	6.1	13.5	ns
t _{PLH} /t _{PHL}	propagation delay \overline{PL} to Q7, $\overline{Q7}$	see Figs 7, 8 and 12	2.3 to 2.7	50	1.0	14.0	28.0	ns
			3.0 to 3.6	50	1.0	10.0	22.0	ns
			4.5 to 5.5	50	1.0	6.5	13.5	ns
t _{PLH} /t _{PHL}	propagation delay D7 to Q7, $\overline{Q7}$	see Figs 9 and 12	2.3 to 2.7	50	1.0	14.0	28.0	ns
			3.0 to 3.6	50	1.0	10.0	20.0	ns
			4.5 to 5.5	50	1.0	6.5	12.5	ns
t _w	clock pulse with HIGH to LOW	see Figs 7, 8 and 12	2.3 to 2.7	–	9.0	–	–	ns
			3.0 to 3.6	–	7.0	–	–	ns
			4.5 to 5.5	–	4.0	–	–	ns
t _w	parallel load pulse with LOW	see Figs 7, 8 and 12	2.3 to 2.7	–	13.0	–	–	ns
			3.0 to 3.6	–	9.0	–	–	ns
			4.5 to 5.5	–	6.0	–	–	ns
t _{rem}	removal time \overline{PL} to CP, \overline{CE}	see Figs 8 and 12	2.3 to 2.7	–	8.5	–	–	ns
			3.0 to 3.6	–	6.0	–	–	ns
			4.5 to 5.5	–	4.0	–	–	ns
t _{su}	set-up time DS to CP, \overline{CE}	see Figs 10, 11 and 12	2.3 to 2.7	–	9.5	–	–	ns
			3.0 to 3.6	–	6.0	–	–	ns
			4.5 to 5.5	–	4.0	–	–	ns
t _{su}	set-up time CE to CP; CP to \overline{CE}	see Figs 10, 11 and 12	2.3 to 2.7	–	7.0	–	–	ns
			3.0 to 3.6	–	5.0	–	–	ns
			4.5 to 5.5	–	3.5	–	–	ns

8-bit parallel-in/serial-out shift register

74LV165A

SYMBOL	PARAMETER	TEST CONDITIONS			MIN.	TYP. ⁽¹⁾	MAX.	UNIT
		WAVEFORMS	V _{CC} (V)	C _L (pF)				
t _{su}	set-up time Don to \overline{PL}	see Figs 10, 11 and 12	2.3 to 2.7	–	12.0	–	–	ns
			3.0 to 3.6	–	8.5	–	–	ns
			4.5 to 5.5	–	5.0	–	–	ns
t _h	hold time DS to CP; \overline{CE} \overline{PL} to CP; \overline{CE}	see Figs 10, 11 and 12	2.3 to 2.7	–	0	–	–	ns
			3.0 to 3.6	–	0	–	–	ns
			4.5 to 5.5	–	0.5	–	–	ns
t _h	hold time Don to \overline{PL}	see Figs 10, 11 and 12	2.3 to 2.7	–	0.5	–	–	ns
			3.0 to 3.6	–	0.5	–	–	ns
			4.5 to 5.5	–	1.0	–	–	ns
f _{max}	maximum clock pulse frequency	see Figs 7 and 12	2.3 to 2.7	15	45	80	–	MHz
			3.0 to 3.6	15	55	115	–	MHz
			4.5 to 5.5	15	90	165	–	MHz
			2.3 to 2.7	50	35	65	–	MHz
			3.0 to 3.6	50	50	90	–	MHz
			4.5 to 5.5	50	85	125	–	MHz

Note

1. All typical values are measured at T_{amb} = 25 °C.

8-bit parallel-in/serial-out shift register

74LV165A

AC WAVEFORMS

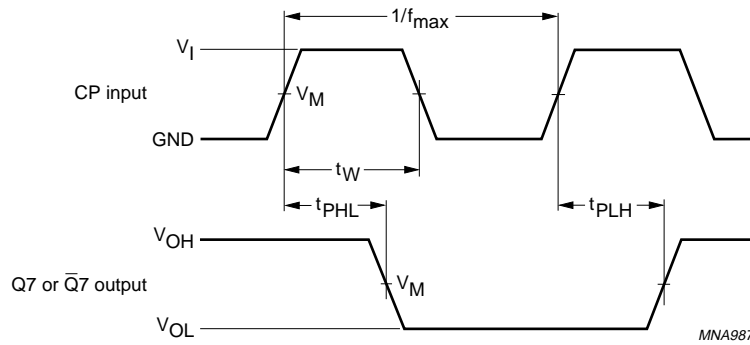

V _{CC}	V _M	INPUT	
		V _I	t _r = t _f
2.3 to 2.7 V	0.5 × V _{CC}	V _{CC}	≤ 3.0 ns
3.0 to 3.6 V	0.5 × V _{CC}	V _{CC}	≤ 3.0 ns
4.5 to 5.5 V	0.5 × V _{CC}	V _{CC}	≤ 3.0 ns

The changing to output assumes internal Q6 opposite state from Q7.

Fig.7 Clock pulse (CP) to output (Q7 or Q7) propagation delays, the clock pulse width and the maximum clock frequency.

8-bit parallel-in/serial-out shift register

74LV165A

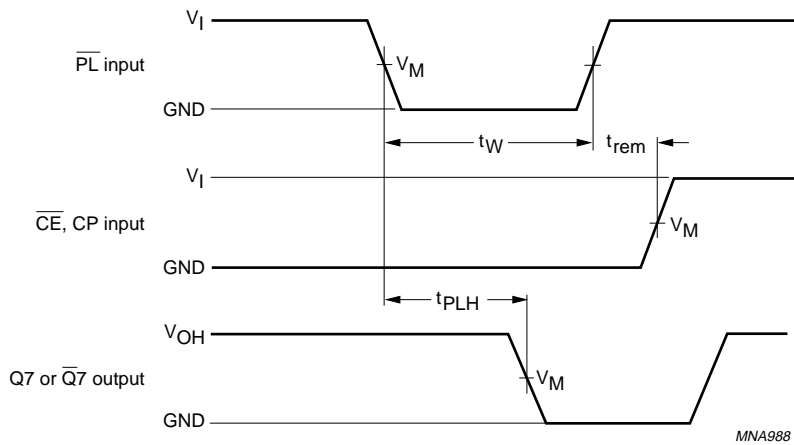

The changing to output assumes internal Q6 opposite state from Q7.

Fig.8 Parallel load (\overline{PL}) pulse width, the parallel load to output (Q7 or $\overline{Q7}$) propagation delays, the parallel load to clock (CP) and clock enable (\overline{CE}) removal time.

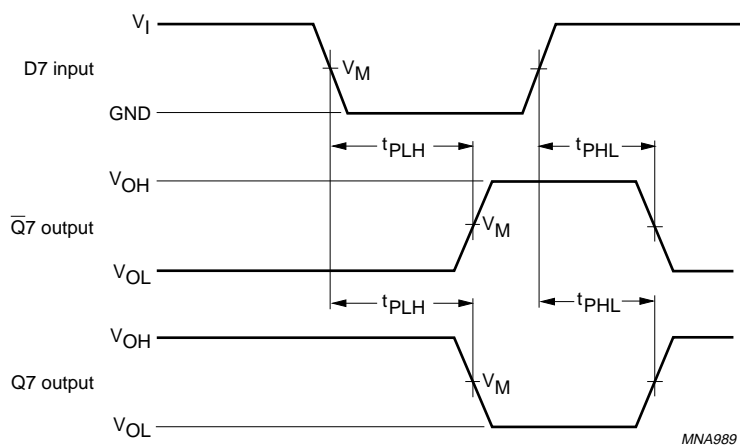

The changing to output assumes internal Q6 opposite state from Q7.

Fig.9 Data input (Don) to output (Q7 or $\overline{Q7}$) propagation delays when \overline{PL} is LOW.

8-bit parallel-in/serial-out shift register

74LV165A

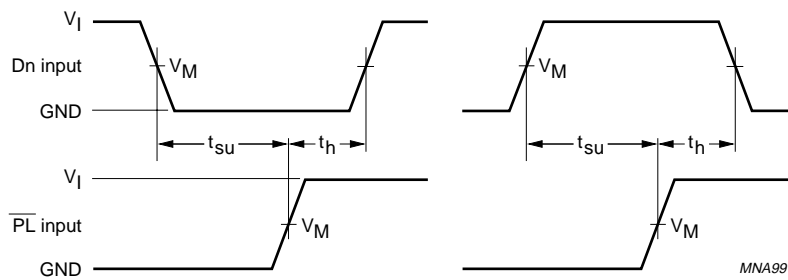
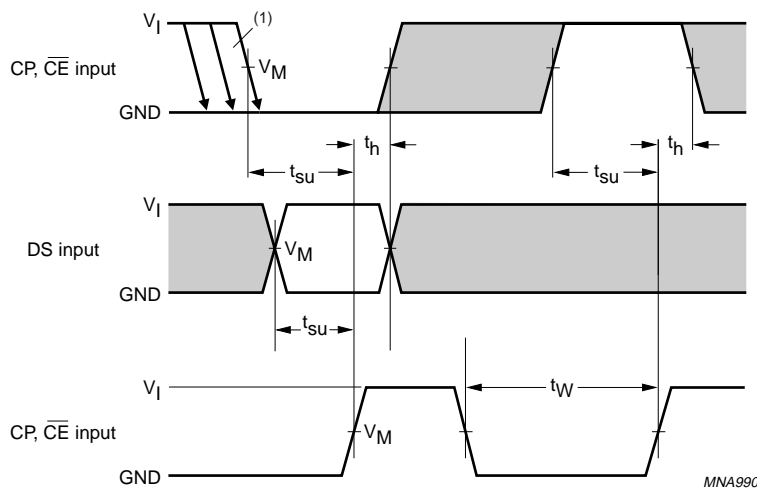

Fig.10 Set-up and hold times from the data inputs (Dn) to the parallel load input (\overline{PL}).



(1) \overline{CE} may change only from HIGH-to-LOW while CP is LOW. The shaded areas indicate when the input is permitted to change for predictable output performance.

Fig.11 Set-up and hold times from the serial data input (DS) to the clock (CP) and the clock enable inputs (\overline{CE}), from the clock enable input (\overline{CE}) to the clock input (CP) and from the clock input (CP) to the clock enable input (\overline{CE}).

8-bit parallel-in/serial-out shift register

74LV165A

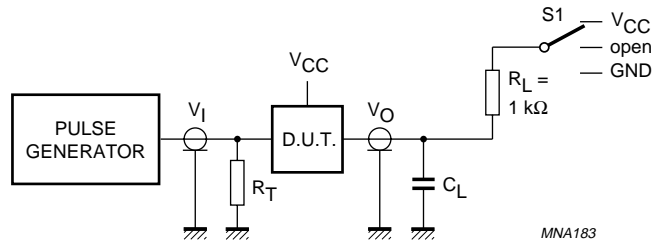

TEST	S1
t_{PLH}/t_{PHL}	open
t_{PLZ}/t_{PZL}	V_{CC}
t_{PHZ}/t_{PZH}	GND

Definitions for test circuit:

R_L = Load resistor.

C_L = Load capacitance including jig and probe capacitance.

R_T = Termination resistance should be equal to the output impedance Z_o of the pulse generator.

Fig.12 Load circuitry for switching times.

8-bit parallel-in/serial-out shift register

74LV165A

PACKAGE OUTLINES

SO16: plastic small outline package; 16 leads; body width 3.9 mm

SOT109-1

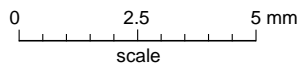
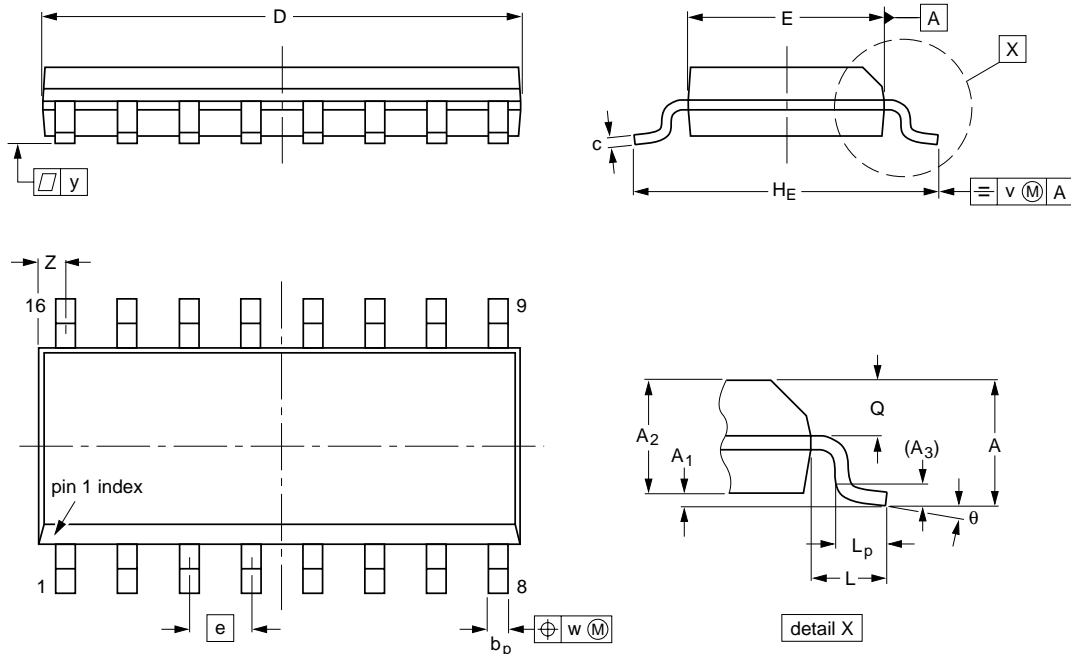

DIMENSIONS (inch dimensions are derived from the original mm dimensions)

UNIT	A max.	A ₁	A ₂	A ₃	b _p	c	D ⁽¹⁾	E ⁽¹⁾	e	H _E	L	L _p	Q	v	w	y	Z ⁽¹⁾	θ
mm	1.75	0.25 0.10	1.45 1.25	0.25	0.49 0.36	0.25 0.19	10.0 9.8	4.0 3.8	1.27	6.2 5.8	1.05	1.0 0.4	0.7 0.6	0.25	0.25	0.1	0.7 0.3	8° 0°
inches	0.069	0.010 0.004	0.057 0.049	0.01	0.019 0.014	0.0100 0.0075	0.39 0.38	0.16 0.15	0.05	0.244 0.228	0.041	0.039 0.016	0.028 0.020	0.01	0.01	0.004	0.028 0.012	

Note

1. Plastic or metal protrusions of 0.15 mm (0.006 inch) maximum per side are not included.

OUTLINE VERSION	REFERENCES			EUROPEAN PROJECTION	ISSUE DATE
	IEC	JEDEC	JEITA		
SOT109-1	076E07	MS-012			99-12-27 03-02-19

8-bit parallel-in/serial-out shift register

74LV165A

TSSOP16: plastic thin shrink small outline package; 16 leads; body width 4.4 mm

SOT403-1

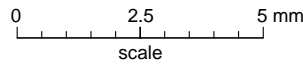
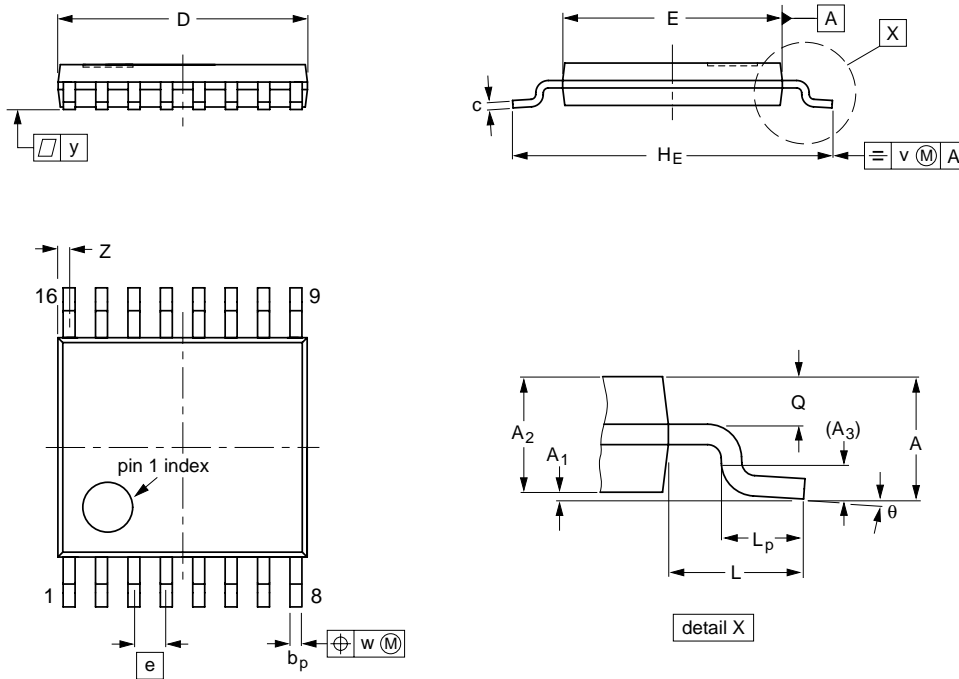

DIMENSIONS (mm are the original dimensions)

UNIT	A max.	A ₁	A ₂	A ₃	b _p	c	D ⁽¹⁾	E ⁽²⁾	e	H _E	L	L _p	Q	v	w	y	z ⁽¹⁾	θ
mm	1.1	0.15 0.05	0.95 0.80	0.25	0.30 0.19	0.2 0.1	5.1 4.9	4.5 4.3	0.65	6.6 6.2	1	0.75 0.50	0.4 0.3	0.2	0.13	0.1	0.40 0.06	8° 0°

Notes

1. Plastic or metal protrusions of 0.15 mm maximum per side are not included.
2. Plastic interlead protrusions of 0.25 mm maximum per side are not included.

OUTLINE VERSION	REFERENCES				EUROPEAN PROJECTION	ISSUE DATE
	IEC	JEDEC	JEITA			
SOT403-1		MO-153				99-12-27 03-02-18

8-bit parallel-in/serial-out shift register

74LV165A

DATA SHEET STATUS

LEVEL	DATA SHEET STATUS ⁽¹⁾	PRODUCT STATUS ⁽²⁾⁽³⁾	DEFINITION
I	Objective data	Development	This data sheet contains data from the objective specification for product development. Philips Semiconductors reserves the right to change the specification in any manner without notice.
II	Preliminary data	Qualification	This data sheet contains data from the preliminary specification. Supplementary data will be published at a later date. Philips Semiconductors reserves the right to change the specification without notice, in order to improve the design and supply the best possible product.
III	Product data	Production	This data sheet contains data from the product specification. Philips Semiconductors reserves the right to make changes at any time in order to improve the design, manufacturing and supply. Relevant changes will be communicated via a Customer Product/Process Change Notification (CPCN).

Notes

1. Please consult the most recently issued data sheet before initiating or completing a design.
2. The product status of the device(s) described in this data sheet may have changed since this data sheet was published. The latest information is available on the Internet at URL [tap://www.semiconductors.philips.com](http://www.semiconductors.philips.com).
3. For data sheets describing multiple type numbers, the highest-level product status determines the data sheet status.

DEFINITIONS

Short-form specification — The data in a short-form specification is extracted from a full data sheet with the same type number and title. For detailed information see the relevant data sheet or data handbook.

Limiting values definition — Limiting values given are in accordance with the Absolute Maximum Rating System (IEC 60134). Stress above one or more of the limiting values may cause permanent damage to the device. These are stress ratings only and operation of the device at these or at any other conditions above those given in the Characteristics sections of the specification is not implied. Exposure to limiting values for extended periods may affect device reliability.

Application information — Applications that are described herein for any of these products are for illustrative purposes only. Philips Semiconductors make no representation or warranty that such applications will be suitable for the specified use without further testing or modification.

DISCLAIMERS

Life support applications — These products are not designed for use in life support appliances, devices, or systems where malfunction of these products can reasonably be expected to result in personal injury. Philips Semiconductors customers using or selling these products for use in such applications do so at their own risk and agree to fully indemnify Philips Semiconductors for any damages resulting from such application.

Right to make changes — Philips Semiconductors reserves the right to make changes in the products - including circuits, standard cells, and/or software - described or contained herein in order to improve design and/or performance. When the product is in full production (status 'Production'), relevant changes will be communicated via a Customer Product/Process Change Notification (CPCN). Philips Semiconductors assumes no responsibility or liability for the use of any of these products, conveys no licence or title under any patent, copyright, or mask work right to these products, and makes no representations or warranties that these products are free from patent, copyright, or mask work right infringement, unless otherwise specified.

Philips Semiconductors – a worldwide company

Contact information

For additional information please visit <http://www.semiconductors.philips.com>. Fax: **+31 40 27 24825**

For sales offices addresses send e-mail to: sales.addresses@www.semiconductors.philips.com.

© Koninklijke Philips Electronics N.V. 2003

SCA75

All rights are reserved. Reproduction in whole or in part is prohibited without the prior written consent of the copyright owner.

The information presented in this document does not form part of any quotation or contract, is believed to be accurate and reliable and may be changed without notice. No liability will be accepted by the publisher for any consequence of its use. Publication thereof does not convey nor imply any license under patent- or other industrial or intellectual property rights.

Printed in The Netherlands

613508/01/pp18

Date of release: 2003 Jul 23

Document order number: 9397 750 11648

Let's make things better.

Philips



PHILIPS