



Part Number 856019

140 MHz SAW Filter

Preliminary Data Sheet

Features

- For broadband applications
- Typical 3 dB bandwidth of 28.5 MHz
- High attenuation
- Single-ended operation
- Ceramic Surface Mount Package (SMP)
- Small size
- Replaces Sawtek P/N 851935

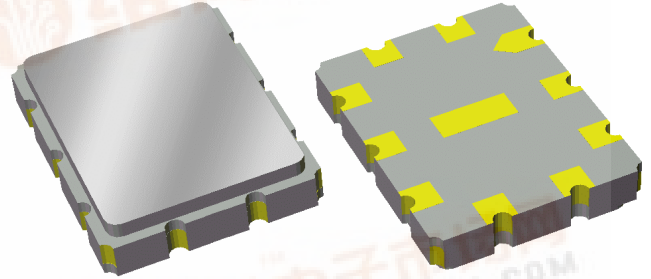

Package

Surface Mount 9.00 x 7.01 x 1.50 mm

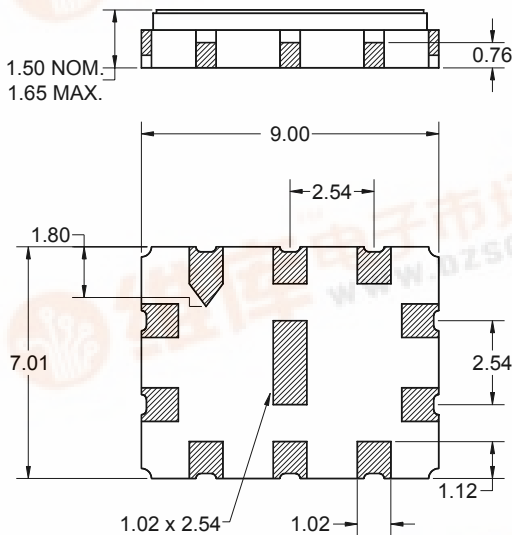

Pin Configuration

Bottom View

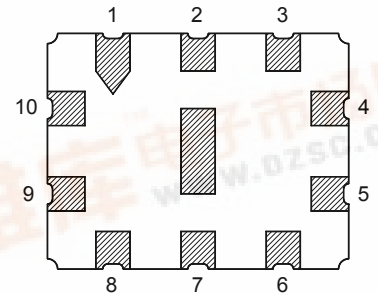

Pin No.	Description
4	Output
5	Output return
9	Input
10	Input return
1,2,3,6,7,8	Case ground

Dimensions shown are nominal in millimeters
 All tolerances are ± 0.15 mm except overall length and width $+0.10$ mm/ -0.15 mm

Body: Al_2O_3 ceramic
 Lid: Kovar, Ni plated

Terminations: Au plating 0.5 - 1.0 μ m,
 over a 2 - 6 μ m Ni plating



Preliminary Data Sheet

Electrical Specifications ⁽¹⁾

Operating Temperature Range: ⁽²⁾ 0 to +70 °C

Parameter ⁽³⁾	Minimum	Typical	Maximum	Unit
Center Frequency	-	140	-	MHz
Maximum Insertion Loss	-	20	21	dB
Lower 1 dB Bandedge ⁽⁴⁾	-	126.45	127.2	MHz
Upper 1 dB Bandedge	152.8	153.75	-	
Lower 3 dB Bandedge ⁽⁴⁾	-	125.53	126.3	MHz
Upper 3 dB Bandedge	153.7	154.46	-	
Lower 40 dB Bandedge ⁽⁴⁾	121.5	122.45	-	MHz
Upper 40 dB Bandedge	-	157.41	158.5	
Amplitude Variation 127.2 - 152.8 MHz	-	0.7	1.0	dB p-p
Phase Linearity 127.2 - 152.8 MHz	-	4.3	7	deg p-p
Group Delay Variation 127.2 - 152.8 MHz	-	22	50	ns p-p
Absolute Delay	-	0.66	-	μsec
Relative Attenuation ⁽⁴⁾				
15 - 90 MHz	45	50	-	dB
90 - 121.5 MHz	40	45	-	dB
158.5 - 190 MHz	37	43	-	dB
190 - 350 MHz	42	51	-	dB
Terminating Source Impedance ⁽⁵⁾	-	50	-	Ω
Terminating Load Impedance ⁽⁵⁾	-	50	-	Ω
Substrate Material	-	128 LiNbO ₃	-	-
Temperature Coefficient of Frequency	-	-74	-	ppm/°C

Notes:

1. All specifications are based on the test circuit shown below
2. In production, devices will be tested at room temperature to a guardbanded specification to ensure electrical compliance over temperature
3. Electrical margin has been built into the design to account for the variations due to temperature and manufacturing tolerances
4. All attenuation measurements are measured relative to minimum insertion loss
5. This is the optimum impedance in order to achieve the performance shown

Test Circuit:

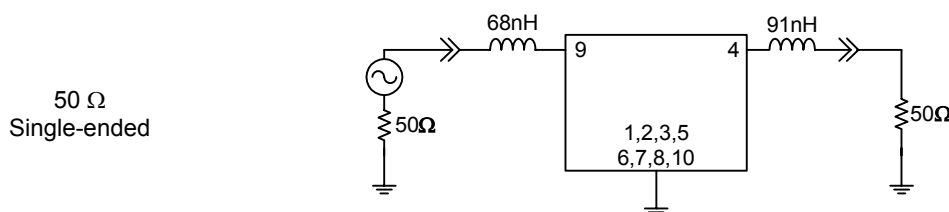

Preliminary Data Sheet

Typical Performance (at +25°C)

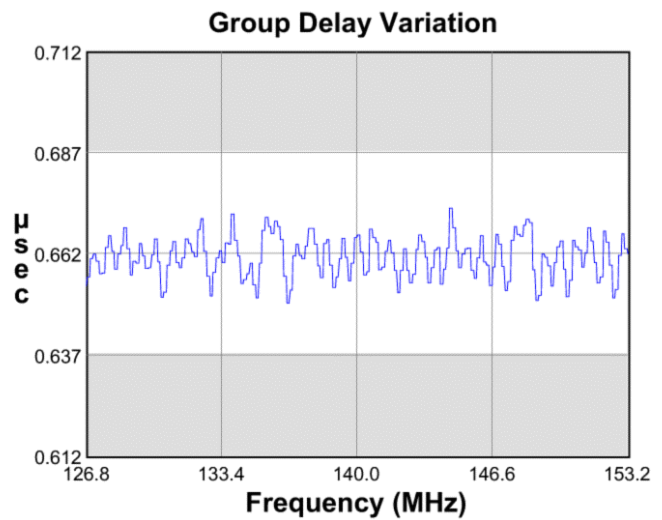
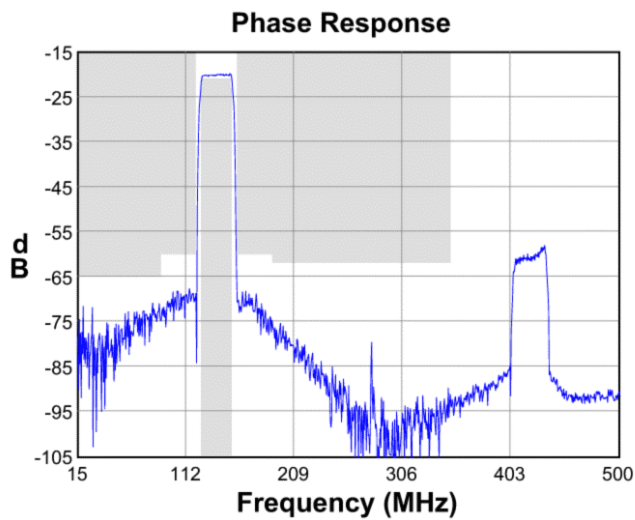
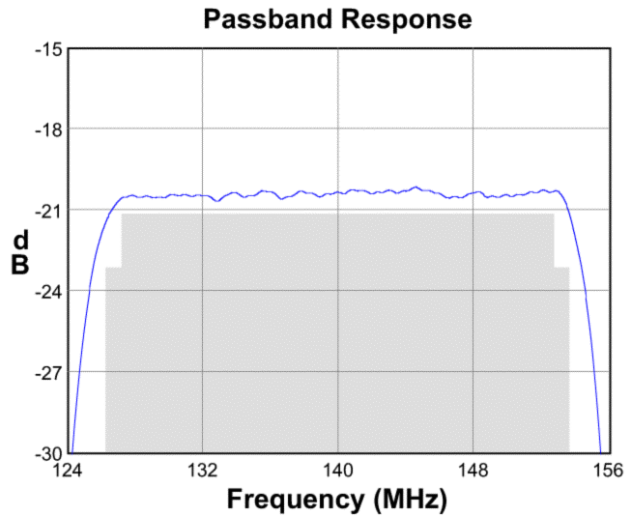
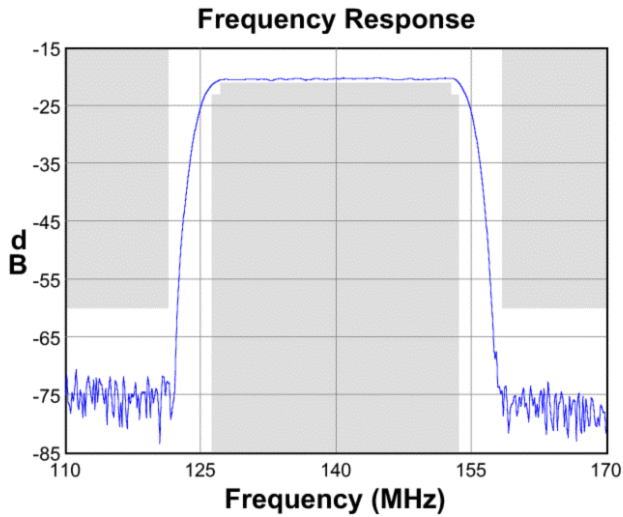

Input Smith Chart

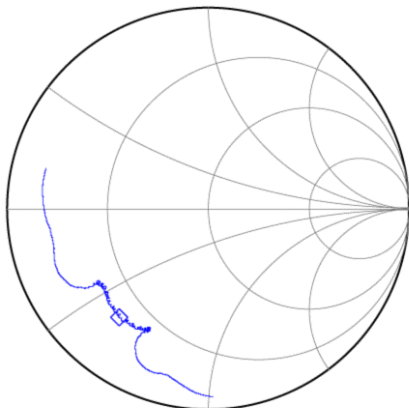

Output Smith Chart

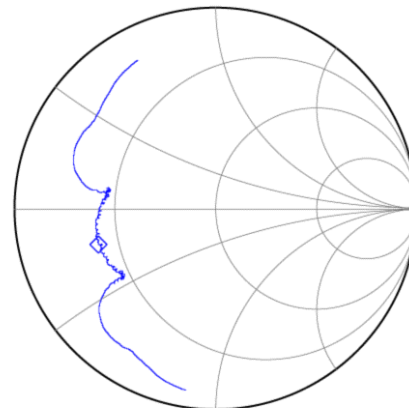

Preliminary Data Sheet

Matching Schematics

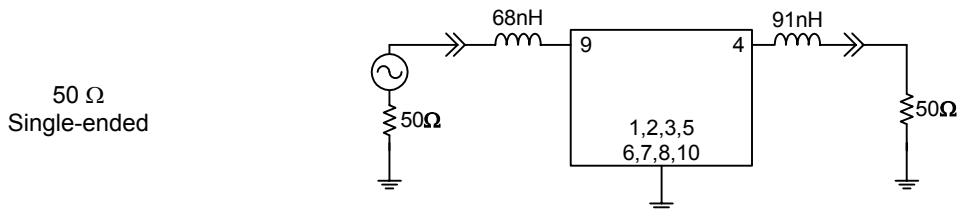

Marking

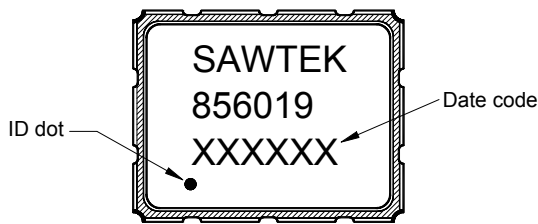

The date code consists of: day of the current year (Julian, 3 digits), last digit of the year (1 digit) and hour (2 digits)

PCB Footprint

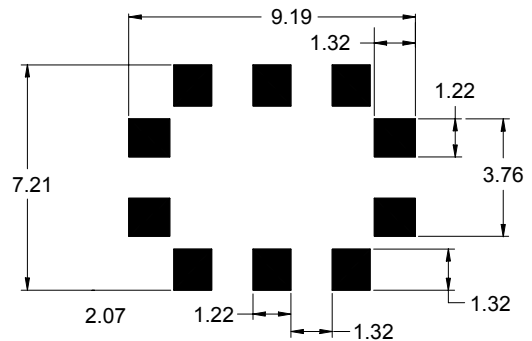

This footprint represents a recommendation only
Dimensions shown are nominal in millimeters

Tape and Reel

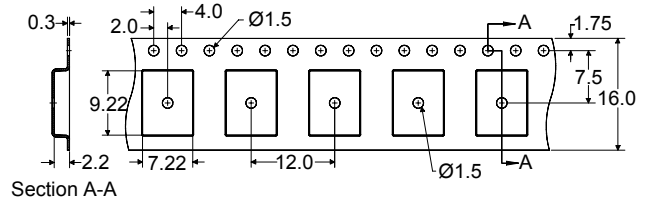
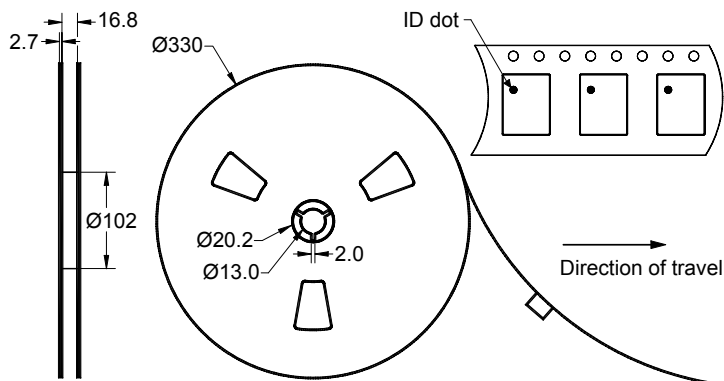

Dimensions shown are nominal in millimeters
Packaging quantity: 2000 units/reel

Preliminary Data Sheet

Maximum Ratings

Parameter	Symbol	Minimum	Typical	Maximum	Unit
Operating Temperature Range	T	0	+25	+70	°C
Storage Temperature Range	T _{stg}	-40	-	+85	°C

Warnings

- Electrostatic Sensitive Device (ESD) 
- Avoid ultrasonic exposure

Links to Additional Technical Information

[PCB Layout Tips](#)

[Qualification Flowchart](#)

[Soldering Profile](#)

[S-Parameters](#)

[Reel and Packaging Label](#)

[Other Technical Information](#)

Sawtek's liability is limited only to the Surface Acoustic Wave (SAW) component(s) described in this data sheet. Sawtek does not accept any liability for applications, processes, circuits or assemblies which are implemented using any Sawtek component described in this data sheet.

Contact Information



PO Box 609501
 Orlando, FL 32860-9501
 USA

Phone: +1 (407) 886-8860
 Fax: +1 (407) 886-7061
 Email: custservice@sawtek.com
 Web: www.sawtek.com

Or contact one of our worldwide
 Network of [sales offices](#),
[Representatives or distributors](#)