



# Part Number 856020

## 140 MHz SAW Filter

### Preliminary Data Sheet

#### Features

- For broadband applications
- Typical 3dB bandwidth of 65 MHz
- High attenuation
- Single-ended operation
- Ceramic Surface Mount Package (SMP)
- Small size
- Replaces Sawtek P/N 851948 (BW 3dB=64 MHz)

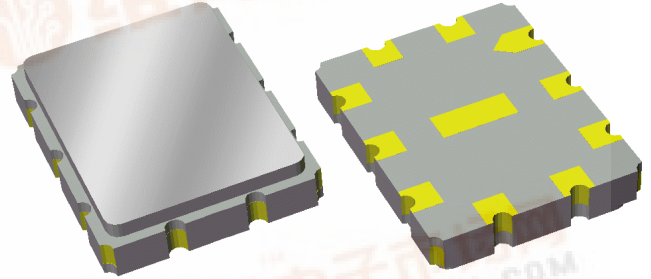

#### Package

Surface Mount 9.00 x 7.01 x 1.50 mm

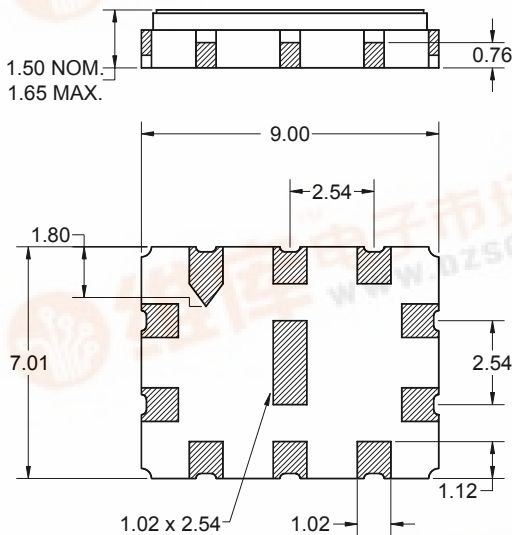

#### Pin Configuration

Bottom View

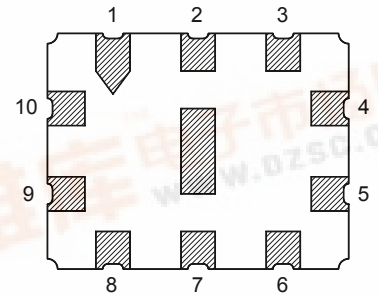

Pin No.	Description
4	Output
5	Output return
9	Input
10	Input return
1,2,3,6,7,8	Case ground

Dimensions shown are nominal in millimeters  
 All tolerances are  $\pm 0.15$ mm except overall length and width  $+0.10$ mm/ $-0.15$ mm

Body:  $Al_2O_3$  ceramic  
 Lid: Kovar, Ni plated

Terminations: Au plating 0.5 - 1.0 $\mu$ m,  
 over a 2 - 6 $\mu$ m Ni plating



# Preliminary Data Sheet

## Electrical Specifications <sup>(1)</sup>

Operating Temperature Range: <sup>(2)</sup> 0 to +70 °C

Parameter <sup>(3)</sup>	Minimum	Typical	Maximum	Unit
Center Frequency	-	140	-	MHz
Minimum Insertion Loss	-	17.8	20	dB
Lower 1 dB Bandedge <sup>(4)</sup>	-	108.85	111.75	MHz
Upper 1 dB Bandedge	168.25	170.27	-	MHz
Lower 3 dB Bandedge <sup>(4)</sup>	-	107.45	108.5	MHz
Upper 3 dB Bandedge	171.5	172.61	-	MHz
Lower 40 dB Bandedge <sup>(4)</sup>	98	102.35	-	MHz
Upper 40 dB Bandedge	-	180.78	182	MHz
Amplitude Variation 111.75 - 168.25 MHz	-	0.6	1.0	dB p-p
Phase Linearity 111.75 - 168.25 MHz	-	5.35	10	deg p-p
Group Delay Variation 111.75 - 168.25 MHz	-	21	55	ns p-p
Absolute Delay	-	0.539	-	µsec
Relative Attenuation <sup>(4)</sup>				
15 - 75 MHz	45	51	-	dB
75 - 98 MHz	40	50	-	dB
182 - 205 MHz	40	43	-	dB
205 - 350 MHz	45	50	-	dB
Terminating Source Impedance <sup>(5)</sup>	-	50	-	Ω
Terminating Load Impedance <sup>(5)</sup>	-	50	-	Ω
Substrate Material	-	128 LiNbO <sub>3</sub>	-	-
Temperature Coefficient of Frequency	-	-74	-	ppm/°C

### Notes:

1. All specifications are based on the test circuit shown below
2. In production, devices will be tested at room temperature to a guardbanded specification to ensure electrical compliance over temperature
3. Electrical margin has been built into the design to account for the variations due to temperature and manufacturing tolerances
4. All attenuation measurements are measured relative to minimum insertion loss
5. This is the optimum impedance in order to achieve the performance shown

### Test Circuit:

Actual matching values may vary due to PCB layout and parasitics

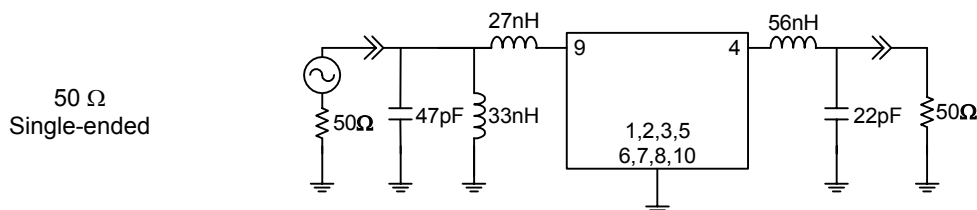

**Preliminary Data Sheet**

**Typical Performance (at +25°C)**

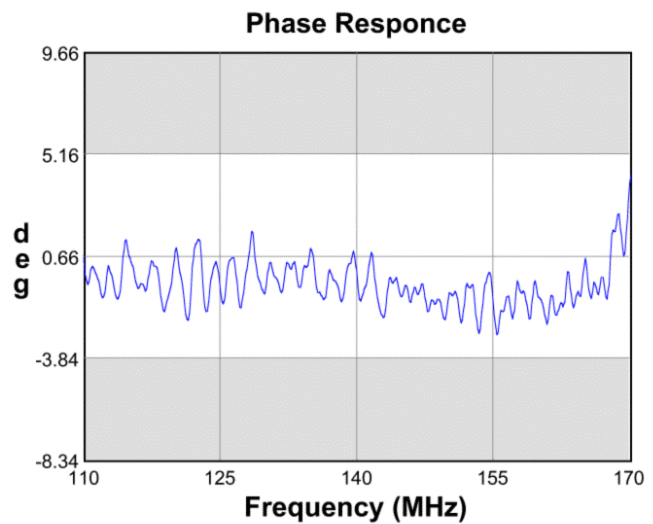
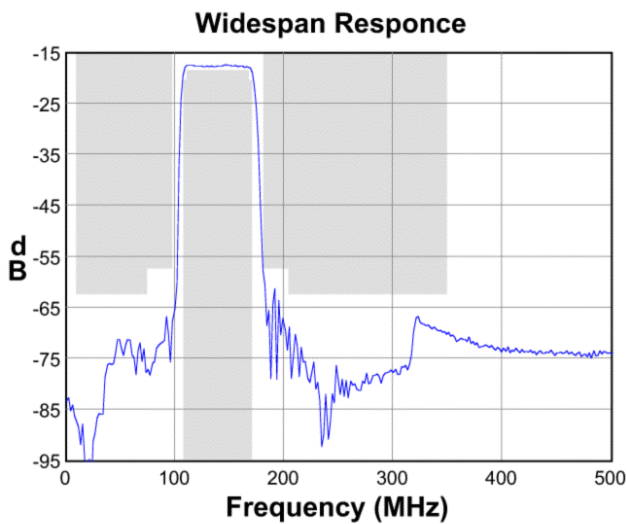
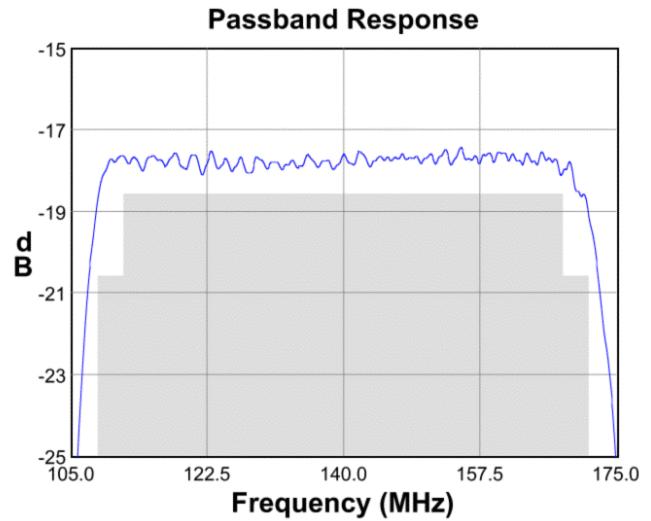
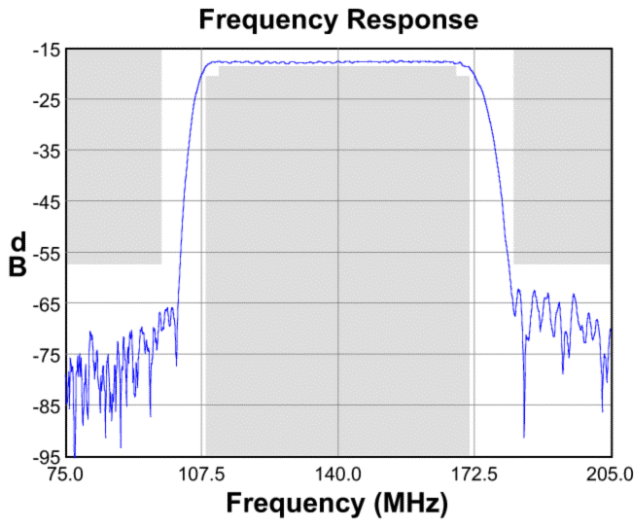

**Input Smith Chart**

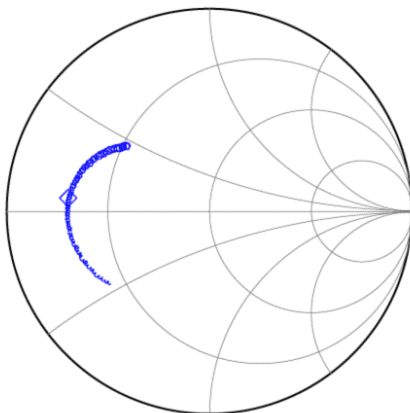

**Output Smith Chart**

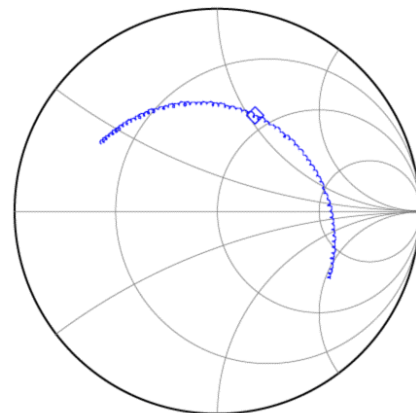

**Preliminary Data Sheet**

**Matching Schematics**

Actual matching values may vary due to PCB layout and parasitics

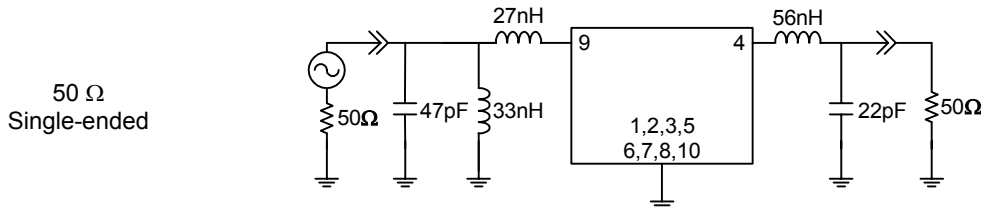

**Marking**



The date code consists of: day of the current year (Julian, 3 digits), last digit of the year (1 digit) and hour (2 digits)

**PCB Footprint**

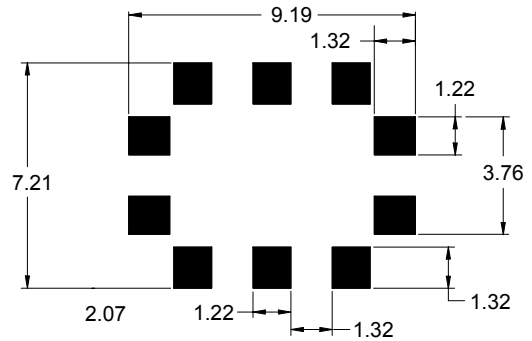

This footprint represents a recommendation only  
Dimensions shown are nominal in millimeters

**Tape and Reel**

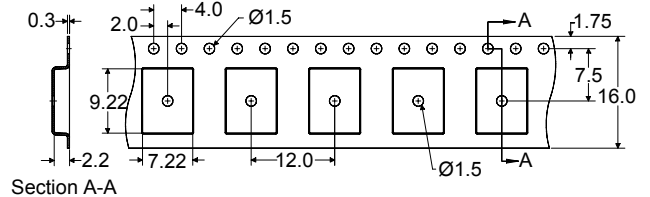
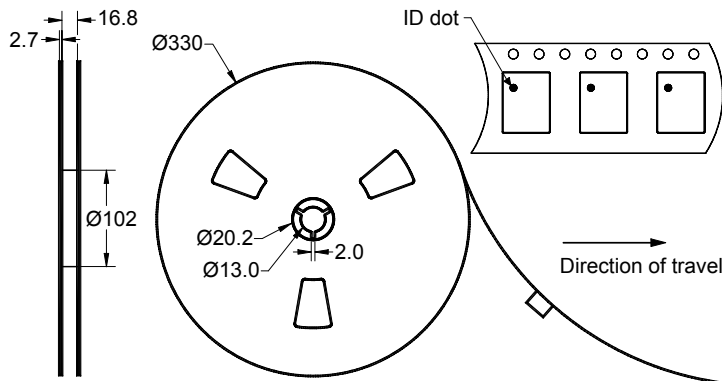

Dimensions shown are nominal in millimeters  
Packaging quantity: 2000 units/reel

# Preliminary Data Sheet

## Maximum Ratings

Parameter	Symbol	Minimum	Typical	Maximum	Unit
Operating Temperature Range	T	0	+25	+70	°C
Storage Temperature Range	T <sub>stg</sub>	-40	-	+85	°C

### Warnings

- Electrostatic Sensitive Device (ESD) 
- Avoid ultrasonic exposure

## Links to Additional Technical Information

[PCB Layout Tips](#)

[Qualification Flowchart](#)

[Soldering Profile](#)

[S-Parameters](#)

[Reel and Packaging Label](#)

[Other Technical Information](#)

Sawtek's liability is limited only to the Surface Acoustic Wave (SAW) component(s) described in this data sheet. Sawtek does not accept any liability for applications, processes, circuits or assemblies which are implemented using any Sawtek component described in this data sheet.

## Contact Information



PO Box 609501  
 Orlando, FL 32860-9501  
 USA

Phone: +1 (407) 886-8860  
 Fax: +1 (407) 886-7061  
 Email: [custservice@sawtek.com](mailto:custservice@sawtek.com)  
 Web: [www.sawtek.com](http://www.sawtek.com)

Or contact one of our worldwide  
 Network of [sales offices](#),  
[Representatives or distributors](#)