



Part Number 856278
374 MHz SAW Filter

Preliminary Data Sheet

Features

- For WLAN applications
- Usable bandwidth of 17 MHz
- Balanced or single-ended operation
- Ceramic Surface Mount Package (SMP)
- Small size

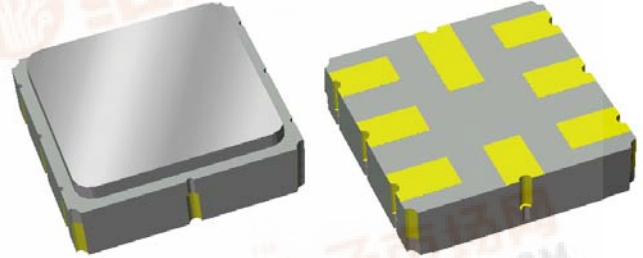

Package

Surface Mount 3.80 x 3.80 x 1.27 mm

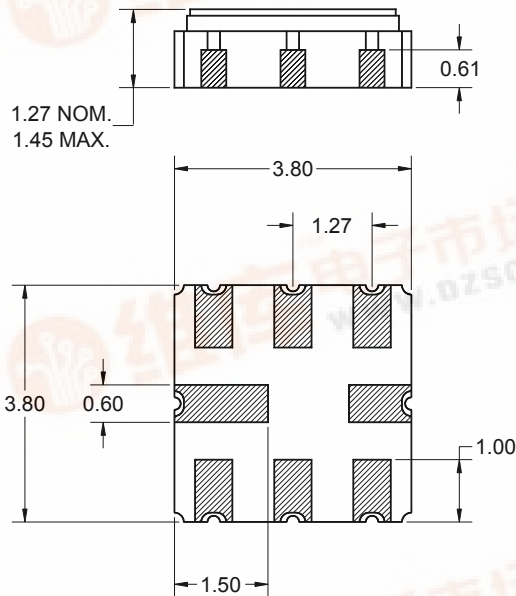

Pin Configuration

Bottom View

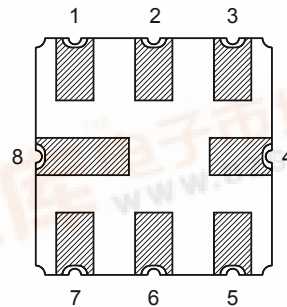

Pin No.	Description
2	Input
3	Input return
6	Output
7	Output return
1,4,5,8	Case ground

Dimensions shown are nominal in millimeters
All tolerances are ± 0.15 mm except overall
length and width ± 0.10 mm

Body: Al_2O_3 ceramic

Lid: Kovar, Ni plated

Terminations: Au plating 0.5 - 1.0 μ m,
over a 2 - 6 μ m Ni plating



Preliminary Data Sheet

Electrical Specifications ⁽¹⁾

Operating Temperature Range: ⁽²⁾ -10 to +80 °C

Parameter ⁽³⁾	Minimum	Typical	Maximum	Unit
Center Frequency, f_0	-	374	-	MHz
Maximum Insertion Loss 367 - 381 MHz	-	9	10	dB
Lower 3 dB Bandedge	-	363.5	365.5	MHz
Upper 3 dB Bandedge	382.5	384.5	-	MHz
Stop Band Rejection ⁽⁴⁾				
274 - 331 MHz	45	50	-	dB
331 - 352 MHz	40	45	-	dB
352 - 357.5 MHz	30	35	-	dB
390.5 - 396 MHz	30	35	-	dB
396 - 404 MHz	35	41	-	dB
404 - 417 MHz	40	45	-	dB
417 - 474 MHz	40	45	-	dB
Amplitude Variation ⁽⁵⁾ 367 - 381 MHz	-	0.75	1.0	dB
Group Delay Variation ⁽⁵⁾ 367 - 381 MHz		40	100	nsec
Triple Transit Suppression	30	40	-	dB
Source Impedance ⁽⁶⁾	-	200	-	Ω
Load Impedance ⁽⁶⁾	-	200	-	Ω

Notes:

1. All specifications are based on the test circuit shown below
2. In production, devices will be tested at room temperature to a guardbanded specification to ensure electrical compliance over temperature
3. Electrical margin has been built into the design to account for the variations due to temperature drift and manufacturing tolerances
4. All attenuation measured over the defined frequency range and referenced to minimum insertion loss
5. Total variation over the defined range
6. This is the optimum impedance in order to achieve the performance shown

Test Circuit:

Actual matching values may vary due to PCB layout and parasitics

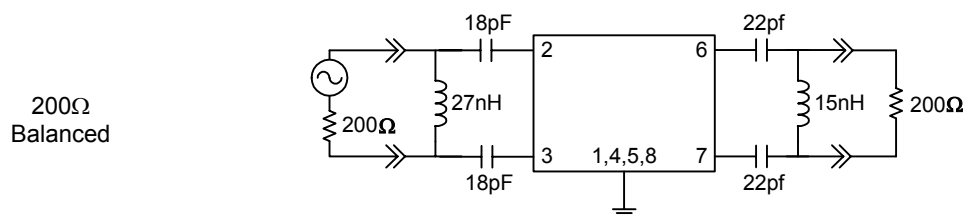

Preliminary Data Sheet

Typical Performance (at +25°C)

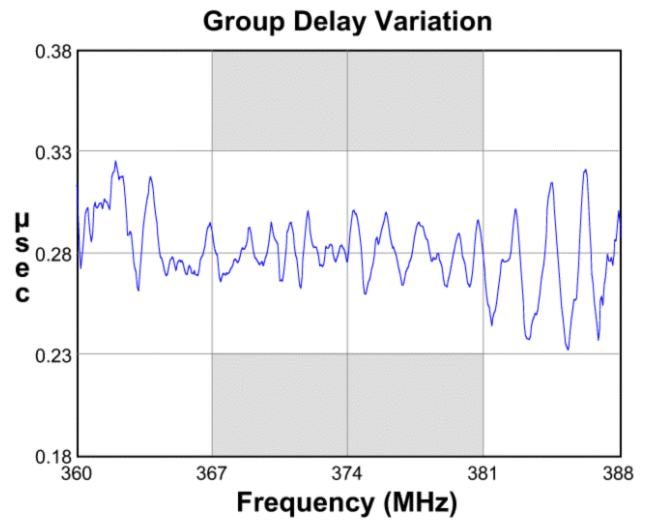
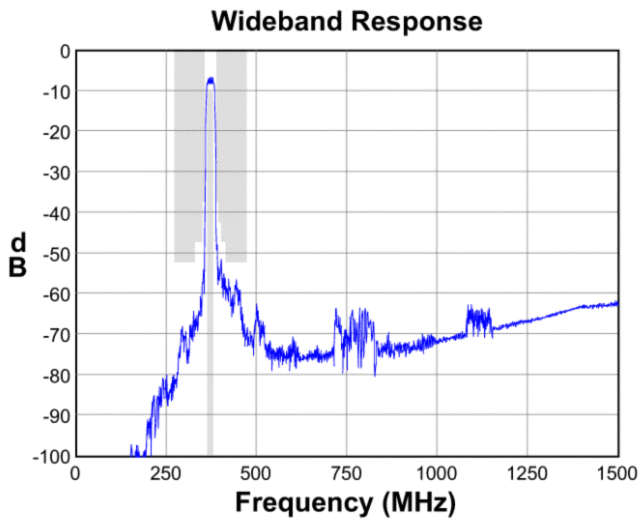
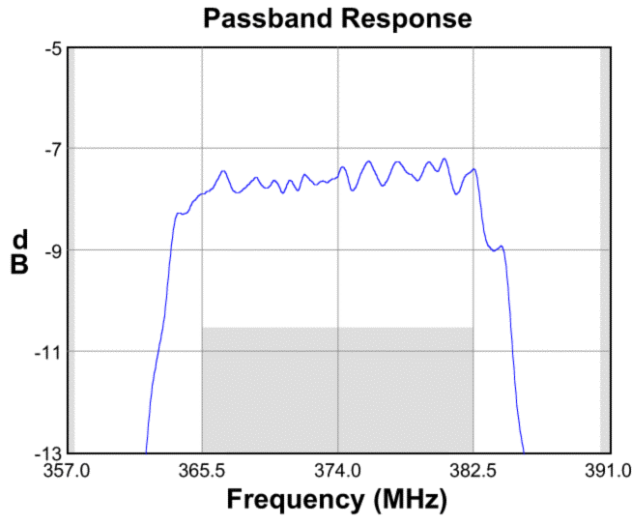
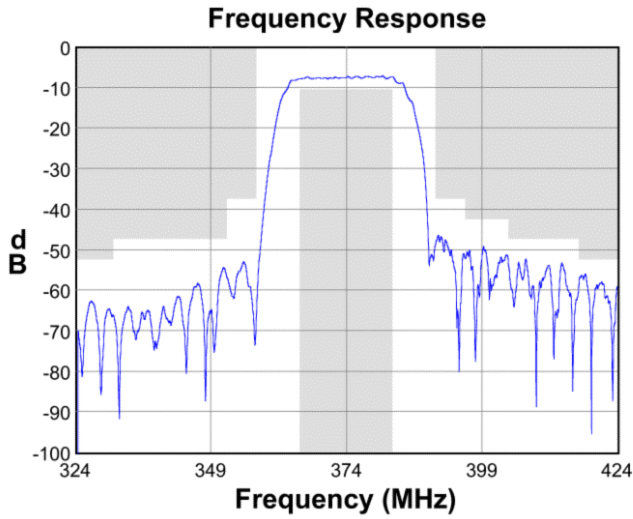

Input Smith Chart

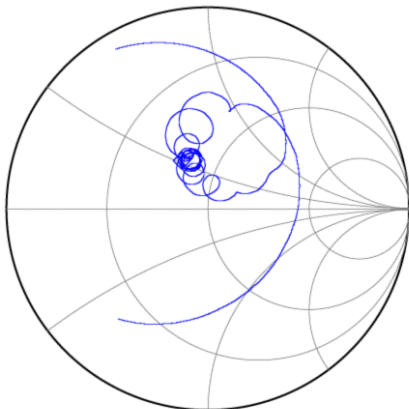

Output Smith Chart

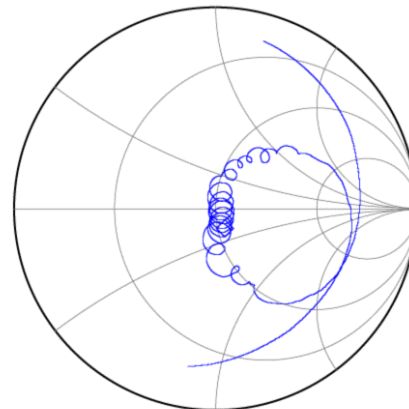

Preliminary Data Sheet

Matching Schematics

Actual matching values may vary due to PCB layout and parasitics

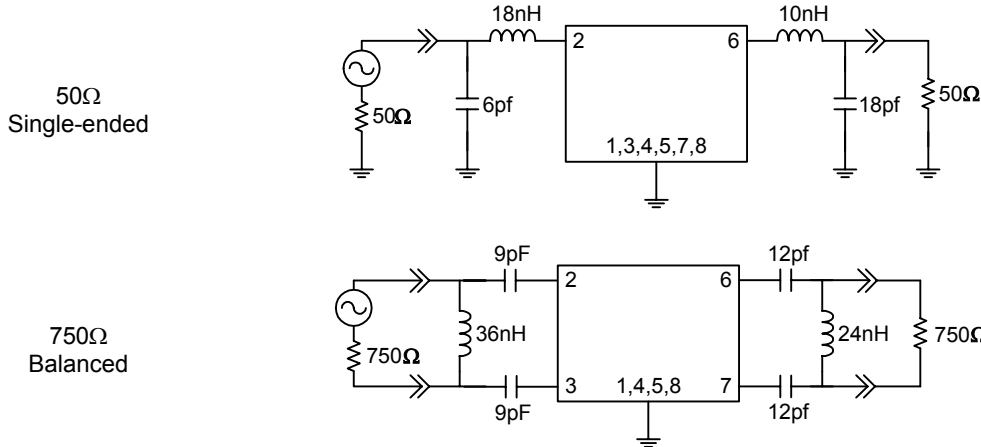

Marking

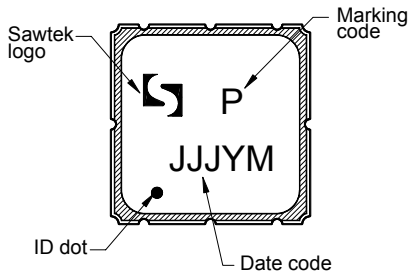

The date code consists of: JJJ = Julian day, Y = last digit of year, M = manufacturing site code

PCB Footprint

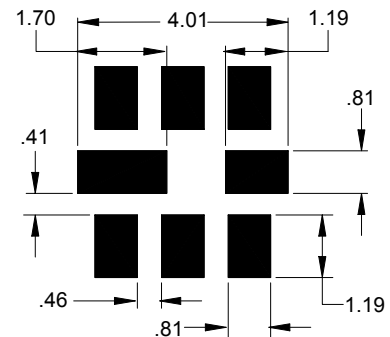

This footprint represents a recommendation only
Dimensions shown are nominal in millimeters

Tape and Reel

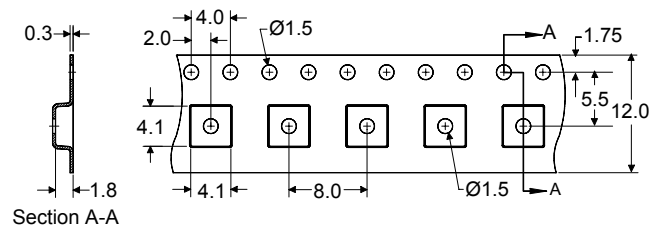
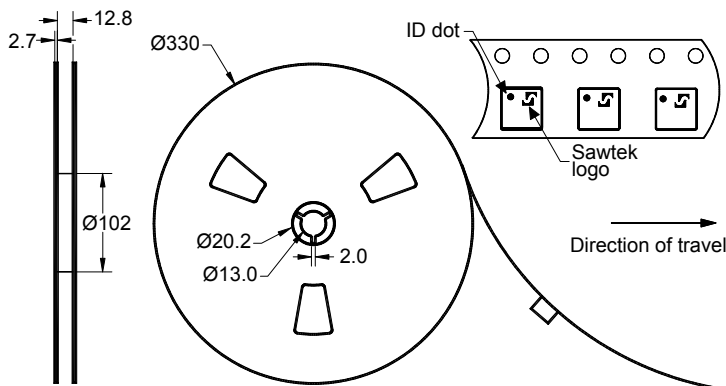

Dimensions shown are nominal in millimeters
Packaging quantity: 4000 units/reel

Preliminary Data Sheet

Maximum Ratings

Parameter	Symbol	Minimum	Maximum	Unit
Operating Temperature Range	T	-10	+85	°C
Storage Temperature Range	T _{stg}	-40	+85	°C
Input Power	P _{in}	-	+10	dBm

Warnings

- Electrostatic Sensitive Device (ESD) 
- Avoid ultrasonic exposure

Links to Additional Technical Information

[PCB Layout Tips](#)

[Qualification Flowchart](#)

[Soldering Profile](#)

[S-Parameters](#)

[Other Technical Information](#)

Sawtek's liability is limited only to the Surface Acoustic Wave (SAW) component(s) described in this data sheet. Sawtek does not accept any liability for applications, processes, circuits or assemblies which are implemented using any Sawtek component described in this data sheet.

Contact Information



PO Box 609501
 Orlando, FL 32860-9501
 USA

Phone: +1 (407) 886-8860
 Fax: +1 (407) 886-7061
 Email: custservice@sawtek.com
 Web: www.sawtek.com

Or contact one of our worldwide network of [sales offices](#), [representatives](#) or [distributors](#)