



Transceiver
Solutions

Alaska® Ultra Gigabit Ethernet Transceivers

88E1011/88E1011S



PRODUCT OVERVIEW

The Marvell® Alaska® family of Gigabit Ethernet (GbE) over copper transceivers are the industry's lowest power, smallest form factor, highest performance, and highest port density solutions in volume production. The Alaska Ultra single-channel GbE transceivers, consisting of the 88E1011 and 88E1011S devices, are the industry's first GbE PHYs optimized for the mobile computing market. These devices perform all of the physical layer functions for 100BASE-TX and 1000BASE-T full or half duplex Ethernet on category 5 (CAT 5) twisted pair cable, and 10BASE-T full or half duplex Ethernet on CAT 3, 4 and 5 cable. The Alaska Ultra+ device (88E1011S) offers additional support of 1000BASE-X through an integrated 1.25 GHz Serializer/Deserializer (SERDES).

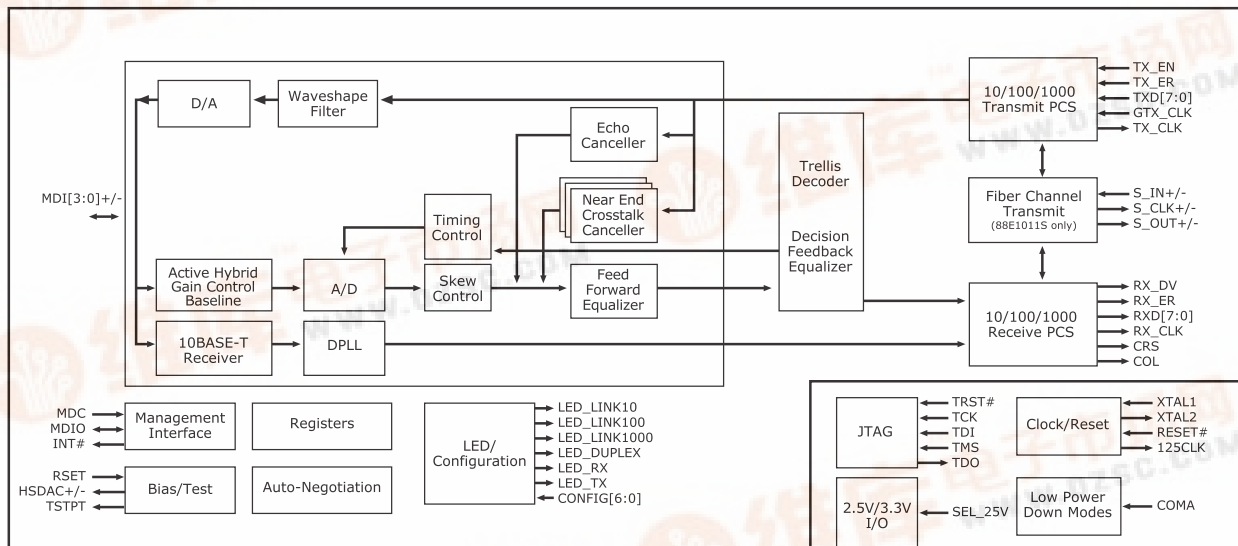

Fig 1. Alaska Ultra GbE Transceiver Block Diagram

FEATURES

- Low power dissipation, just over 1W
- IEEE 802.3 compliant 1000BASE-T, 100BASE-TX and 10BASE-T transceivers
- GMII, TBI, RTBI, RGMII, SGMII interfaces
- Integrated 1.25 GHz SERDES (88E1011S)
- Media Detect feature automatically detects and configures to either copper or fiber media
- Four power management modes
- Auto-MDI/MDIX crossover at all three speeds
- IEEE 1149.1 (JTAG) boundary scan support
- Advanced mixed-signal and DSP techniques
- Advanced baseline wander correction

BENEFITS

- Enables higher integration and reduced cost
- True plug-and-play with 10/100/1000BASE-T tri-speed functionality
- Provide a seamless Ethernet solution
- Supports 1000BASE-X fiber applications
- Complete media flexibility
- Extend battery life; reduce power consumption
- End-to-end wiring tolerance and correction
- Increased reliability for board level testing and manufacturability
- Advanced DSP design
- Provides robust performance over a wide range of operating conditions





FEATURES

- Fully integrated digital adaptive equalizers, echo and crosstalk cancellers
- On-chip transmit wave-shaping to reduce EMI
- Advice internal hybrids for 1000BASE-T
- Three package options: 128-pin PQFP, 117-pin TFBGA and 96-pin BCC
- 0.15-micron standard digital CMOS process

BENEFITS

- Optimized cable performance
- Better FCC performance
- Lower cost magnetic
- Small package outline, 9mm x 9mm (BCC)
- Advanced process for reduced power and cost to achieve the highest port density

APPLICATIONS

The Marvell Alaska Ultra GbE transceiver supports advanced power management modes, including Wake-on-LAN, which are critical to client applications such as Gigabit-connected laptop computers. The device also provides complete flexibility in media selection — either copper or fiber media. The Alaska Ultra PHY's Media Detect feature automatically senses whether the end-user has inserted a CAT 5 copper or fiber-optic cable, performs Auto-Negotiation and provides seamless plug-and-play configuration.

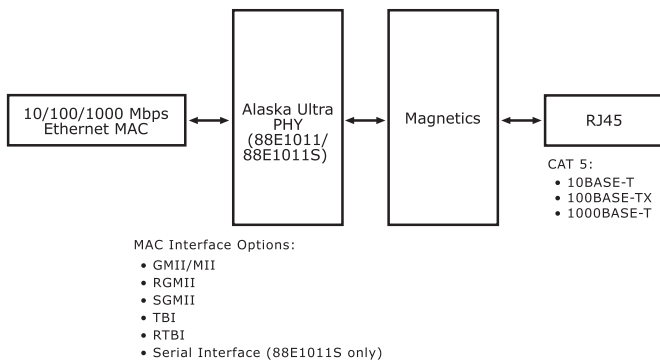

Fig 2. Alaska Ultra GbE Transceiver CAT 5 Application Diagram

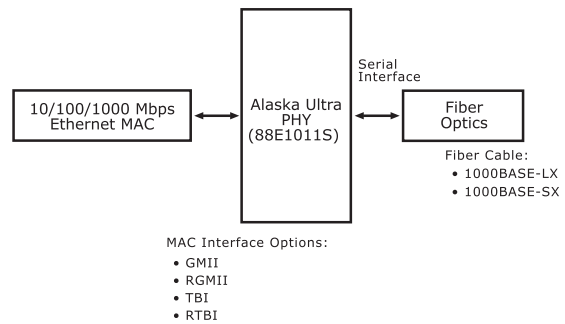

Fig 3. Alaska Ultra GbE Transceiver (88E1011S only) Fiber-Optics Application Diagram

THE MARVELL ADVANTAGE: The Marvell Alaska Ultra GbE transceivers come with a complete set of hardware and software development tools to assist network hardware engineers with product evaluation. Marvell's worldwide field applications engineers collaborate closely with network equipment vendors to develop and deliver new competitive products to market on time. Marvell utilizes recognized world-leading semiconductor foundry and packaging services to reliably deliver high-volume and low cost total solutions.

For more information, visit our website at www.marvell.com.



Marvell Semiconductor, Inc.

700 First Avenue
Sunnyvale, CA 94089
Phone 408.222.2500

©2002 Marvell International Ltd. All rights reserved. Marvell, the Marvell logo, Moving Forward Faster, Alaska, the Galileo logo, and GalNet are registered trademarks of Marvell. Discovery, Fastwriter, Galileo Technology, GalTis, Horizon, Libertas, Pretera, and Virtual Cable Tester are trademarks of Marvell. All other trademarks are the property of their respective owners.

100110-001 05/02