



**05H1
THRU
05H6**

SURFACE MOUNT HIGH EFFICIENCY RECTIFIER

VOLTAGE RANGE 50 to 600 Volts CURRENT 0.5 Ampere

FEATURES

- * Low power loss, high efficiency
- * Low leakage
- * Low forward voltage
- * High current capability
- * High speed switching
- * High surge capability
- * High reliability

MECHANICAL DATA

- * Epoxy: Device has UL flammability classification 94V-O
- * Mounting position: Any
- * Weight: 0.016 gram

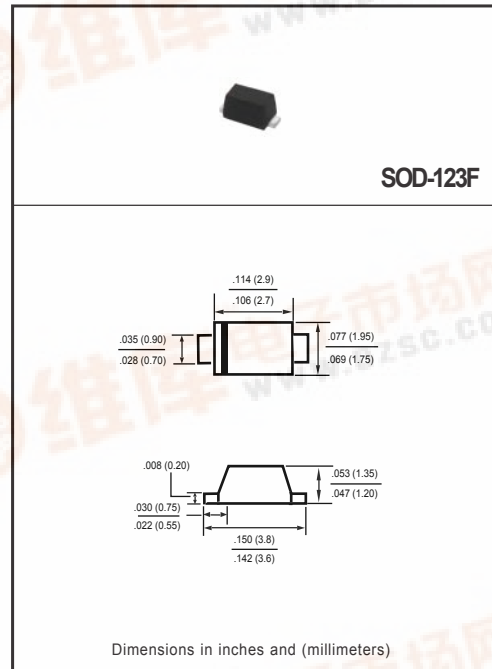

MAXIMUM RATINGS AND ELECTRICAL CHARACTERISTICS

Ratings at 25 °C ambient temperature unless otherwise specified.
Single phase, half wave, 60 Hz, resistive or inductive load.
For capacitive load, derate current by 20%.

MAXIMUM RATINGS (@ TA=25 °C unless otherwise noted)

RATINGS	SYMBOL	05H1	05H2	05H3	05H4	05H5	05H6	UNITS
Maximum Recurrent Peak Reverse Voltage	VRRM	50	100	200	300	400	600	Volts
Maximum RMS Voltage	VRMS	35	70	140	210	280	420	Volts
Maximum DC Blocking Voltage	VDC	50	100	200	300	400	600	Volts
Maximum Average Forward Rectified Current at TA= 55°C	IO	0.5						Amps
Peak Forward Surge Current 8.3 ms single half sine-wave superimposed on rated load (JEDEC method)	IFSM	15						Amps
Typical Thermal Resistance (Note 4)	RθJA	130						°C/W
	RθJL	30						
Typical Junction Capacitance (Note 2)	CJ	15					12	pF
Operating and Storage Temperature Range	TJ, TSTG	-55 to + 150						°C

ELECTRICAL CHARACTERISTICS (At TA = 25°C unless otherwise noted)

CHARACTERISTICS	SYMBOL	05H1	05H2	05H3	05H4	05H5	05H6	UNITS
Maximum Instantaneous Forward Voltage at 0.5A DC	VF	1.0			1.3		1.7	Volts
Maximum DC Reverse Current at Rated DC Blocking Voltage TA = 25°C	IR	5.0						uAmps
Maximum Full Load Reverse Current Average, Full Cycle .375" (9.5mm) lead length at TL = 55°C		100						
Maximum Reverse Recovery Time (Note 1)	trr	50					75	nSec

- NOTES : 1. Test Conditions: IF = 0.5A, IR = -1.0A, IRR = -0.25A
 2. Measured at 1 MHz and applied reverse voltage of 4.0 volts
 3. "Fully ROHS compliant", "100% Sn plating (Pb-free)".
 4. Thermal Resistance : Mounted on PCB.



RATING AND CHARACTERISTICS CURVES (05H1 THRU 05H6)

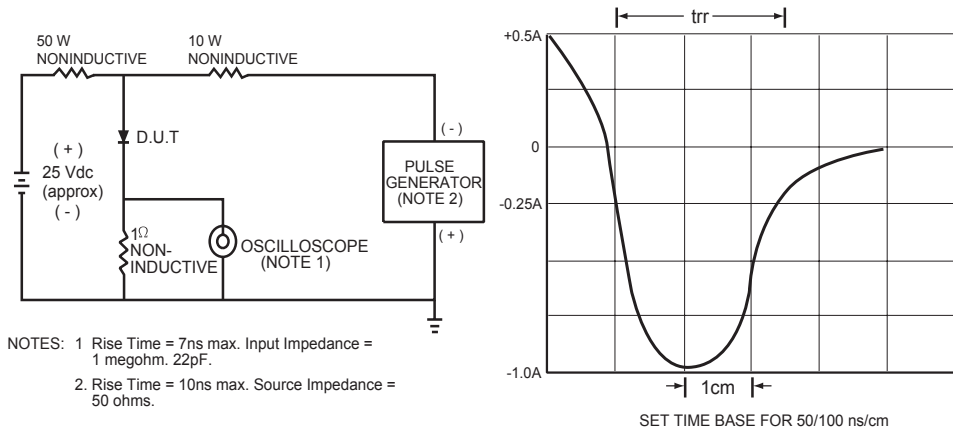

FIG.1 TEST CIRCUIT DIAGRAM AND REVERSE RECOVERY TIME CHARACTERISTIC

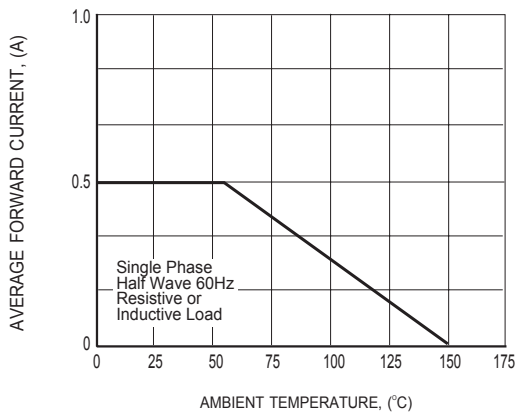

FIG.2 TYPICAL FORWARD CURRENT DERATING CURVE

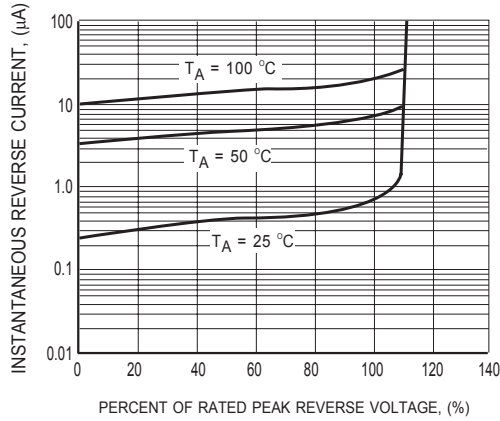

FIG.3 TYPICAL REVERSE CHARACTERISTICS

RATING AND CHARACTERISTICS CURVES (05H1 THRU 05H6)

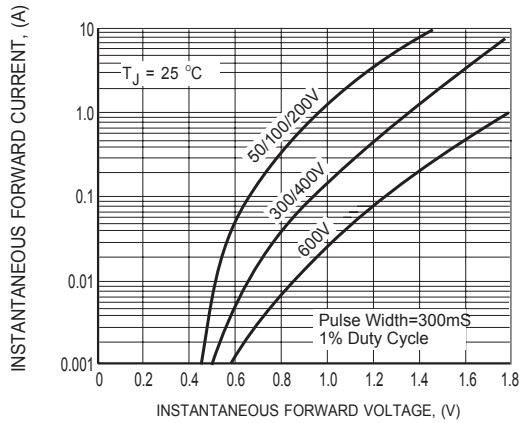

FIG.4 TYPICAL INSTANTANEOUS FORWARD CHARACTERISTICS

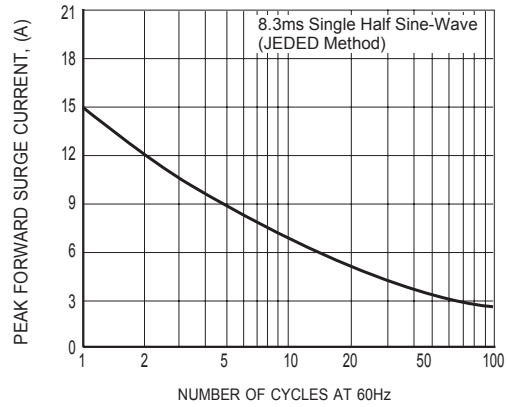

FIG.5 MAXIMUM NON-REPETITIVE FORWARD SURGE CURRENT

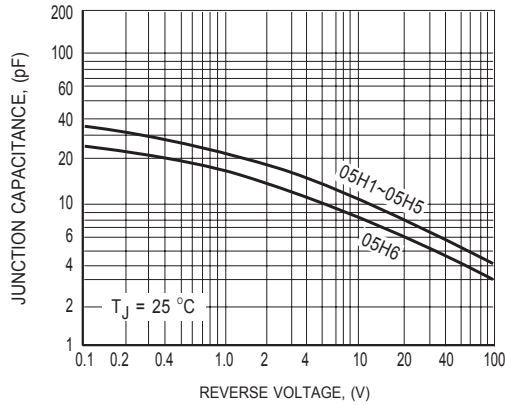
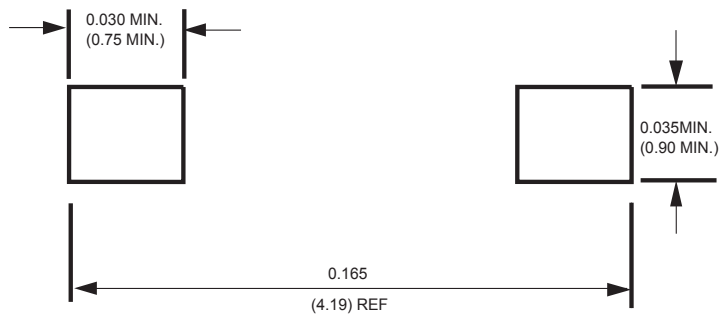

FIG.6 TYPICAL JUNCTION CAPACITANCE

Mounting Pad Layout



Dimensions in inches and (millimeters)

