

TECHNICAL DATA

Precision Air-Core Tach/Speedo Driver with Return to Zero

IL8190N

Functional Description

The IL8190N is specifically designed for use with air-core meter movements. The IC provides all the functions necessary for an analog tachometer or speedometer. The IL8190N takes a speed sensor input and generates sine and cosine related output signals to differentially drive an air-core meter.

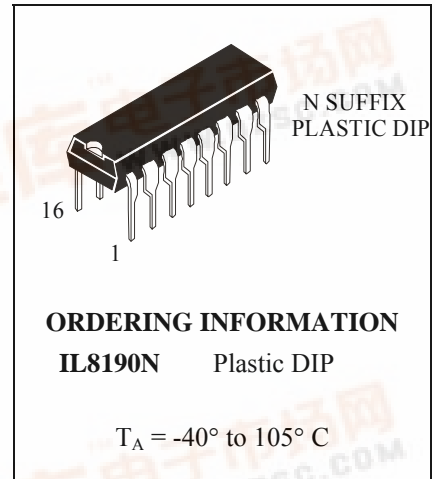

Features

- Direct Sensor Input
- High Output Torque
- Low Pointer Flutter
- High Input Impedance
- Overvoltage Protection
- Return to Zero

PIN ASSIGNMENT

| | | | |
|--------------------|---|----|---------------------|
| CP+ | 1 | 16 | CP- |
| SQ _{OUT} | 2 | 15 | V _{OUT} /F |
| FREQ _{IN} | 3 | 14 | V _{REG} |
| GND | 4 | 13 | GND |
| GND | 5 | 12 | GND |
| COS+ | 6 | 11 | SIN+ |
| COS- | 7 | 10 | SIN- |
| V _{CC} | 8 | 9 | BIAS |

Absolute Maximum Ratings*

| Symbol | Parameter | Value | Unit |
|------------------|---|------------------------|------|
| V _{CC} | Supply Voltage | 100 ms Pulse Transient | 60 |
| | | Continuous | 24 |
| Topr | Operating Temperature | -40 to +105 | °C |
| T _J | Junction Temperature | -40 to +150 | °C |
| T _{stg} | Storage Temperature | -60 to +165 | °C |
| T _L | Lead Temperature Soldering: Wave Solder (through hole styles only) (Note) | 260 peak | °C |
| | ESD (Human Body Model) | 4.0 | kV |

Note: 10 seconds maximum.

*The maximum package power dissipation must be observed.

Block Diagram

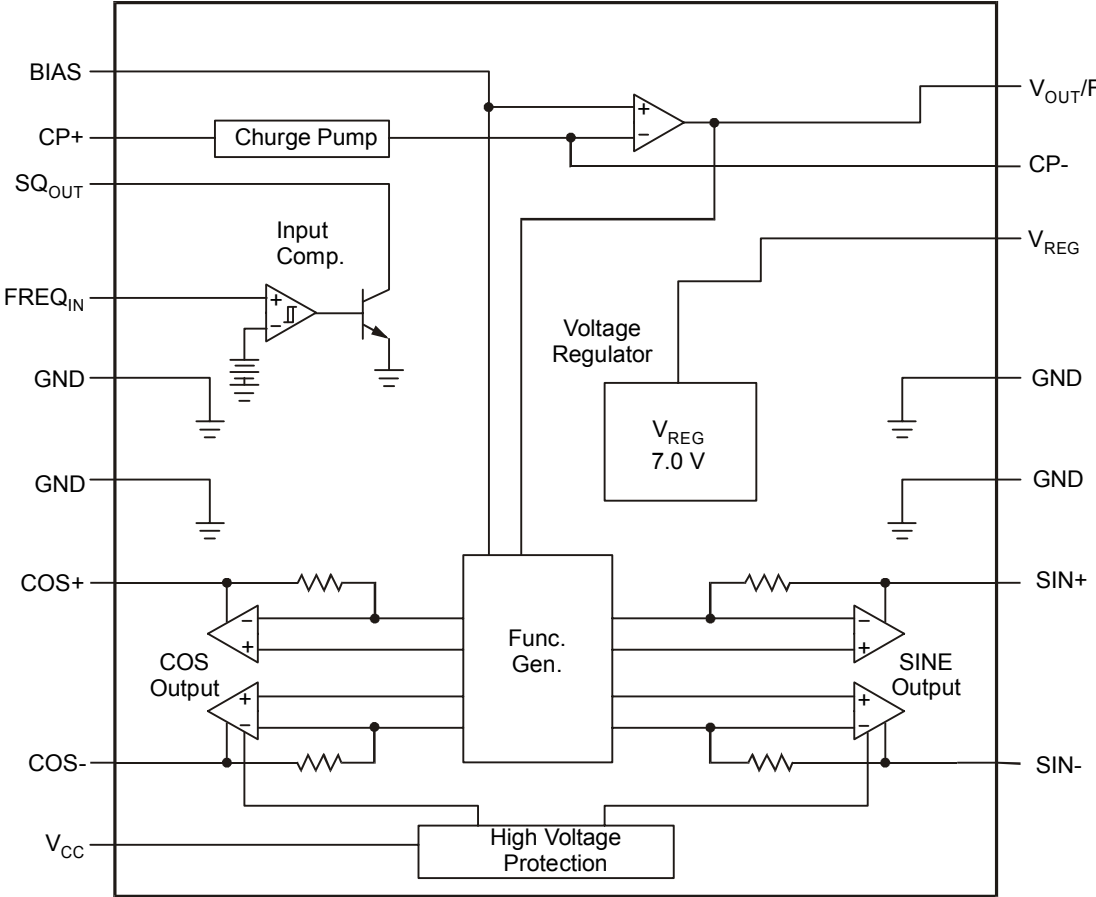

Pin Discriptions

| Pin No. | Symbol | Function |
|--------------|--------------------|---|
| 1 | CP+ | Positive input to charge pump |
| 2 | SQ _{OUT} | Buffered square wave output signal |
| 3 | FREQ _{IN} | Speed or RPM input signal |
| 4, 5, 12, 13 | GND | Ground Connections |
| 6 | COS+ | Positive cosine output signal |
| 7 | COS- | Negative cosine output signal |
| 8 | V _{CC} | Ignition or battery supply voltage |
| 9 | BIAS | Test point or zero adjustment |
| 10 | SIN- | Negative sine output signal |
| 11 | SIN+ | Positive sine output signal |
| 14 | V _{REG} | Voltage regulator output |
| 15 | V _{OUT/F} | Output voltage proportional to input signal frequency |
| 16 | CP- | Negative input to charge pump |

Electrical Characteristics ($-40^{\circ}\text{C} \leq T_A \leq 85^{\circ}\text{C}$, $8.5\text{ V} \leq V_{CC} \leq 16\text{ V}$, unless otherwise specified)

| Symbol | Parameter | Test Condition | Min | Typ | Max | Unit |
|--|--|---|-------|------|----------|---------------|
| Supply Voltage Section | | | | | | |
| I_{CC} | Supply Current | $V_{CC} = 16\text{ V}$, No Load | | 66 | 125 | mA |
| V_{CC} | Normal Operation Range | | 8.5 | 13.1 | 16 | V |
| Input Comparator Section | | | | | | |
| V_{TH} | Positive Input Threshold | | 1.0 | 2.1 | 3.0 | V |
| V_H | Input Hysteresis | | 200 | 470 | – | mV |
| I_{IB1} | Input Bias Current (Note 1) | $0\text{ V} \leq V_{IN} \leq 8.0\text{ V}$ | – | -4 | -80 | μA |
| F_{IN} | Input Frequency Range | | 0 | - | 20 | kHz |
| V_{IN} | Input Voltage Range | in series with $1.0\text{ k}\Omega$ | -1.0 | - | V_{CC} | V |
| V_{SAT} | Output V_{SAT} | $I_O = 10\text{ mA}$ | – | 0.10 | 0.40 | V |
| I_{SING} | Output Leakage | $V_O = 7.0\text{ V}$ | – | 0.02 | 10 | μA |
| V_{CC-TH} | Low V_{CC} Disable Threshold | | 7.0 | 8.0 | 8.5 | V |
| V_L | Logic 0 Input Voltage | | 1.0 | 1.6 | – | V |
| Voltage Regulator Section | | | | | | |
| V_{REF} | Output Voltage | | 6.25 | 7.00 | 7.50 | V |
| I_O | Output Load Current | | - | - | 10 | mA |
| $\Delta V_{REF-LOAD}$ | Output Load Regulation | 0 to 10 mA | – | 4 | 50 | mV |
| $\Delta V_{REF-LINE}$ | Output Line Regulation | $8.5\text{ V} \leq V_{CC} \leq 16\text{ V}$ | – | 30 | 150 | mV |
| PRS | Power Supply Rejection | $V_{CC} = 13.1\text{ V}$, 1.0 V_{PIP} 1.0 kHz | 34 | 46 | – | dB |
| Charge Pump Section | | | | | | |
| U_{INV} | Inverting Input Voltage | | 1.5 | 2.1 | 2.5 | V |
| I_{IB2} | Input Bias Current | | – | 35 | 150 | nA |
| V_{BIAS} | V_{BIAS} Input Voltage | | 1.5 | 2.1 | 2.5 | V |
| U_{NINV} | Non Invert. Input Voltage | $I_{IN} = 1.0\text{ mA}$ | – | 0.6 | 1.1 | V |
| L_K | Linearity (Note 2) | @ 0; 87.5; 175; 262.5; + 350 Hz | -0.10 | 0.27 | +0.70 | % |
| K | V_{OUT}/F Gain | @ 350 Hz, $C_{CP} = 0.0033\text{ }\mu\text{F}$, $R_T = 243\text{ k}\Omega$ | 7.0 | 11 | 13 | mV/Hz |
| G_{N+} | Norton Gain, Positive | $I_{IN} = 15\text{ }\mu\text{A}$ | 0.9 | 1.0 | 1.1 | |
| G_{N-} | Norton Gain, Negative | $I_{IN} = 15\text{ }\mu\text{A}$ | 0.9 | 1.0 | 1.1 | |
| Function Generator Section: $-40^{\circ}\text{C} \leq T_A \leq 85^{\circ}\text{C}$, $V_{CC} = 13.1\text{ V}$ unless otherwise noted | | | | | | |
| V_{CC-TH1} | Return to Zero Threshold | $T_A = 25^{\circ}\text{C}$ | 5.2 | 6.0 | 7.0 | V |
| $V_{(COS+-COS-)}$ | Differential Drive Voltage ($V_{COS+} - V_{COS-}$) | $8.5\text{ V} \leq V_{CC} \leq 16\text{ V}$, $\Theta = 0^{\circ}$ | 5.5 | 6.5 | 7.5 | V |
| $V_{(SIN+-SIN-)}$ | Differential Drive Voltage ($V_{SIN+} - V_{SIN-}$) | $8.5\text{ V} \leq V_{CC} \leq 16\text{ V}$, $\Theta = 90^{\circ}$ | 5.5 | 6.5 | 7.5 | V |
| $V_{(COS+-COS-)}$ | Differential Drive Voltage ($V_{COS+} - V_{COS-}$) | $8.5\text{ V} \leq V_{CC} \leq 16\text{ V}$, $\Theta = 180^{\circ}$ | -7.5 | -6.5 | -5.5 | V |
| $V_{(SIN+-SIN-)}$ | Differential Drive Voltage ($V_{SIN+} - V_{SIN-}$) | $8.5\text{ V} \leq V_{CC} \leq 16\text{ V}$, $\Theta = 270^{\circ}$ | -7.5 | -6.5 | -5.5 | V |
| I_{OUT} | Differential Drive Current | $8.5\text{ V} \leq V_{CC} \leq 16\text{ V}$ | – | 33 | 42 | mA |
| Θ | Zero Hertz Output Angle | | -1.5 | 0 | 1.5 | deg |
| | Function Generator Error (Note 3) Reference Figures 1, 2, 3, 4 | $V_{CC} = 13.1\text{ V}$ $\Theta = 0^{\circ}$ to 305° | -2.0 | 0 | +2.0 | deg |

Electrical Characteristics (continued)

($-40^{\circ}\text{C} \leq T_A \leq 85^{\circ}\text{C}$, $8.5\text{ V} \leq V_{CC} \leq 16\text{ V}$, unless otherwise specified)

| Symbol | Parameter | Test Condition | Min | Typ | Max | Unit |
|--|--------------------------|--|------|-----|------|--------------|
| Function Generator Section: $-40^{\circ}\text{C} \leq T_A \leq 85^{\circ}\text{C}$, $V_{CC} = 13.1\text{ V}$ unless otherwise noted (continued) | | | | | | |
| | Function Generator Error | $13.1\text{ V} \leq V_{CC} \leq 16\text{ V}$ | -2.5 | 0 | +2.5 | deg |
| | Function Generator Error | $13.1\text{ V} \leq V_{CC} \leq 11\text{ V}$ | -1.0 | 0 | +1.0 | deg |
| | Function Generator Error | $13.1\text{ V} \leq V_{CC} \leq 9.0\text{ V}$ | -3.0 | 0 | +3.0 | deg |
| | Function Generator Error | $25^{\circ}\text{C} \leq T_A \leq 80^{\circ}\text{C}$ | -3.0 | 0 | +3.0 | deg |
| | Function Generator Error | $25^{\circ}\text{C} \leq T_A \leq 105^{\circ}\text{C}$ | -5.5 | 0 | +5.5 | deg |
| | Function Generator Error | $-40^{\circ}\text{C} \leq T_A \leq 25^{\circ}\text{C}$ | -3.0 | 0 | +3.0 | deg |
| Θ/V | Function Generator Gain | $T_A = 25^{\circ}\text{C}$, Θ vs V_{OUT}/F | 60 | 77 | 95 | $^{\circ}/V$ |

Notes:

1. Input is clamped by an internal 12 V Zener.
2. Applies to % of full scale (270°).
3. Deviation from nominal per Table 1 after calibration at 0° and 270° .

Typical Performance Characteristics

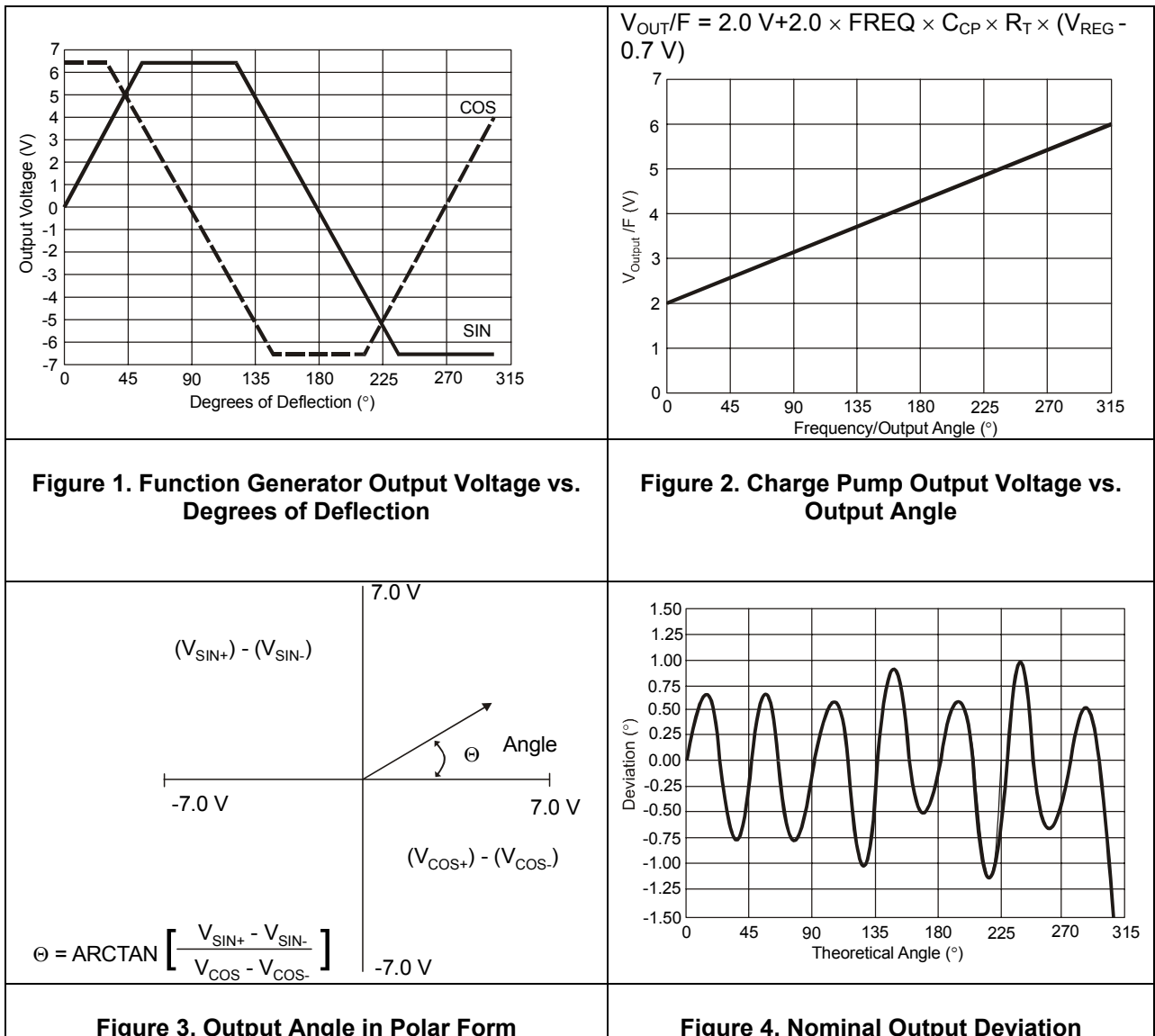

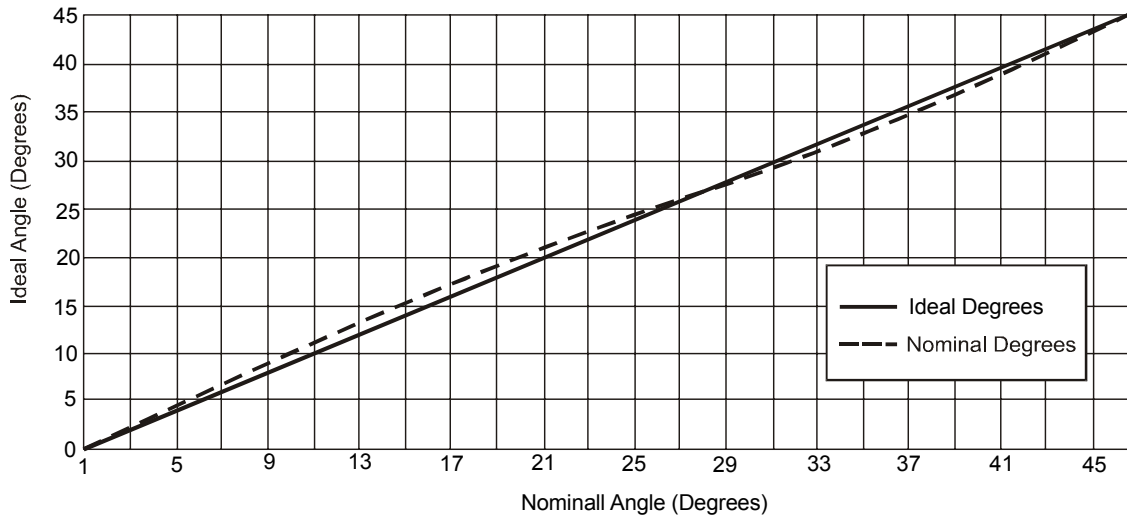

Figure 5. Nominal Angle vs. Ideal Angle (After Calibrating at 180°)

Table 1. Function Generator Output Nominal Angle vs. Ideal Angle (After Calibrating at 270°)

| Ideal Degrees | Nomi-nal Degrees | Ideal Degrees | Nomi-nal Degrees | Ideal Degrees | Nomi-nal Degrees | Ideal Degrees | Nomi-nal Degrees | Ideal Degrees | Nomi-nal Degrees | Ideal Degrees | Nomi-nal Degrees |
|---------------|------------------|---------------|------------------|---------------|------------------|---------------|------------------|---------------|------------------|---------------|------------------|
| 0 | 0 | 17 | 17.98 | 34 | 33.04 | 75 | 74.00 | 160 | 159.14 | 245 | 244.63 |
| 1 | 1.09 | 18 | 18.96 | 35 | 34.00 | 80 | 79.16 | 165 | 164.00 | 250 | 249.14 |
| 2 | 2.19 | 19 | 19.92 | 36 | 35.00 | 85 | 84.53 | 170 | 169.16 | 255 | 254.00 |
| 3 | 3.29 | 20 | 20.86 | 37 | 36.04 | 90 | 90.00 | 175 | 174.33 | 260 | 259.16 |
| 4 | 4.38 | 21 | 21.79 | 38 | 37.11 | 95 | 95.47 | 180 | 180.00 | 265 | 264.53 |
| 5 | 5.47 | 22 | 22.71 | 39 | 38.21 | 100 | 100.84 | 185 | 185.47 | 270 | 270.00 |
| 6 | 6.56 | 23 | 23.61 | 40 | 39.32 | 105 | 106.00 | 190 | 190.84 | 275 | 275.47 |
| 7 | 7.64 | 24 | 24.50 | 41 | 40.45 | 110 | 110.86 | 195 | 196.00 | 280 | 280.84 |
| 8 | 8.72 | 25 | 25.37 | 42 | 41.59 | 115 | 115.37 | 200 | 200.86 | 285 | 286.00 |
| 9 | 9.78 | 26 | 26.23 | 43 | 42.73 | 120 | 119.56 | 205 | 205.37 | 290 | 290.86 |
| 10 | 10.84 | 27 | 27.07 | 44 | 43.88 | 125 | 124.00 | 210 | 209.56 | 295 | 295.37 |
| 11 | 11.90 | 28 | 27.79 | 45 | 45.00 | 130 | 129.32 | 215 | 214.00 | 300 | 299.21 |
| 12 | 12.94 | 29 | 28.73 | 50 | 50.68 | 135 | 135.00 | 220 | 219.32 | 305 | 303.02 |
| 13 | 13.97 | 30 | 29.56 | 55 | 56.00 | 140 | 140.68 | 225 | 225.00 | | |
| 14 | 14.99 | 31 | 30.39 | 60 | 60.44 | 145 | 146.00 | 230 | 230.58 | | |
| 15 | 16.00 | 32 | 31.24 | 65 | 64.63 | 150 | 150.44 | 235 | 236.00 | | |
| 16 | 17.00 | 33 | 32.12 | 70 | 69.14 | 155 | 154.63 | 240 | 240.44 | | |

Note: Temperature, voltage and nonlinearity not included.

Circuit Description and Application Notes

The IL8190N is specifically designed for use with air-core meter movements. It includes an input comparator for sensing an input signal from an ignition pulse or speed sensor, a charge pump for frequency to voltage conversion, a bandgap voltage regulator for stable operation, and a function generator with sine and cosine amplifiers to differentially drive the meter coils.

From the partial schematic of Figure 6, the input signal is applied to the $FREQ_{IN}$ lead, this is the input to a high impedance comparator with a typical positive input threshold of 2.0 V and typical hysteresis of 0.5 V. The output of the comparator, SQ_{OUT} , is applied to the charge pump input $CP+$ through an external capacitor C_{CP} . When the input signal changes state, C_{CP} is charged or discharged through $R3$ and $R4$. The charge accumulated on C_{CP} is mirrored to $C4$ by the Norton Amplifier circuit comprising of $Q1$, $Q2$ and $Q3$. The charge pump output voltage, $V_{OUT/F}$, ranges from 2.0 V to 6.3 V depending on the input signal frequency and the gain of the charge pump according to the formula:

$$V_{OUT/F} = 2.0 \text{ V} + 2.0 \times \text{FREQ} \times C_{CP} \times R_T \times (V_{REG} - 0.7 \text{ V})$$

R_T is a potentiometer used to adjust the gain of the V/F output stage and give the correct meter deflection. The V/F output voltage is applied to the function generator which generates the sine and

cosine output voltages. The output voltage of the sine and cosine amplifiers are derived from the on-chip amplifier and function generator circuitry. The various trip points for the circuit (i.e., 0° , 90° , 180° , 270°) are determined by an internal resistor divider and the bandgap voltage reference. The coils are differentially driven, allowing bidirectional current flow in the outputs, thus providing up to 305° range of meter deflection. Driving the coils differentially offers faster response time, higher current capability, higher output voltage swings, and reduced external component count. The key advantage is a higher torque output for the pointer.

The output angle, Θ , is equal to the V/F gain multiplied by the function generator gain:

$$\Theta = A_{V/F} \times A_{FG}$$

where:

$$A_{FG} = 77^\circ/\text{V}(\text{typ})$$

The relationship between input frequency and output angle is:

$$\Theta = A_{FG} \times 2.0 \times \text{FREQ} \times C_{CP} \times R_T \times (V_{REG} - 0.7 \text{ V})$$

or, $\Theta = 970 \times \text{FREQ} \times C_{CP} \times R_T$

The ripple voltage at the V/F converter's output is determined by the ratio of C_{CP} and $C4$ in the formula:

$$\Delta V = \frac{C_{CP}(V_{REG} - 0.7 \text{ V})}{C4}$$

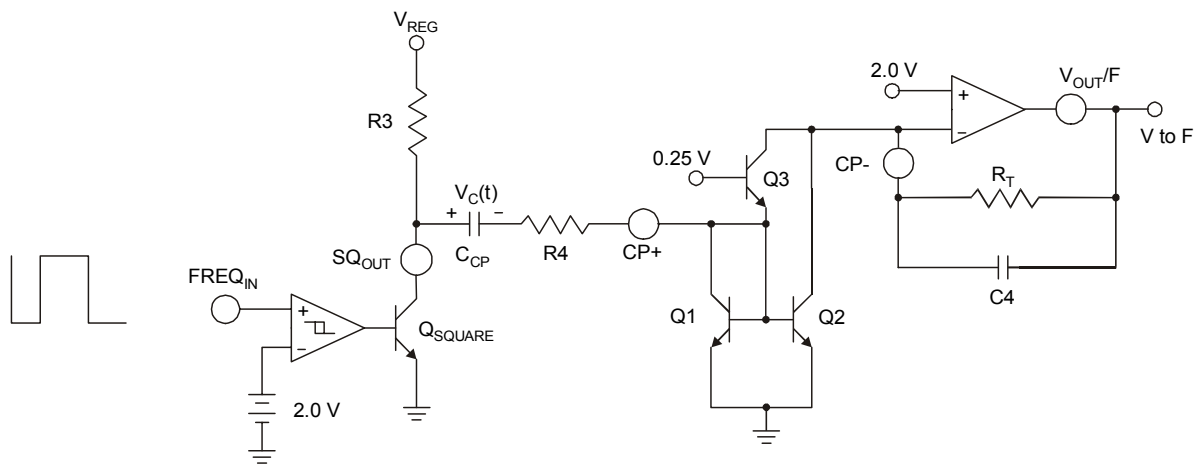

Figure 6. Partial Schematic of Input and Charge Pump

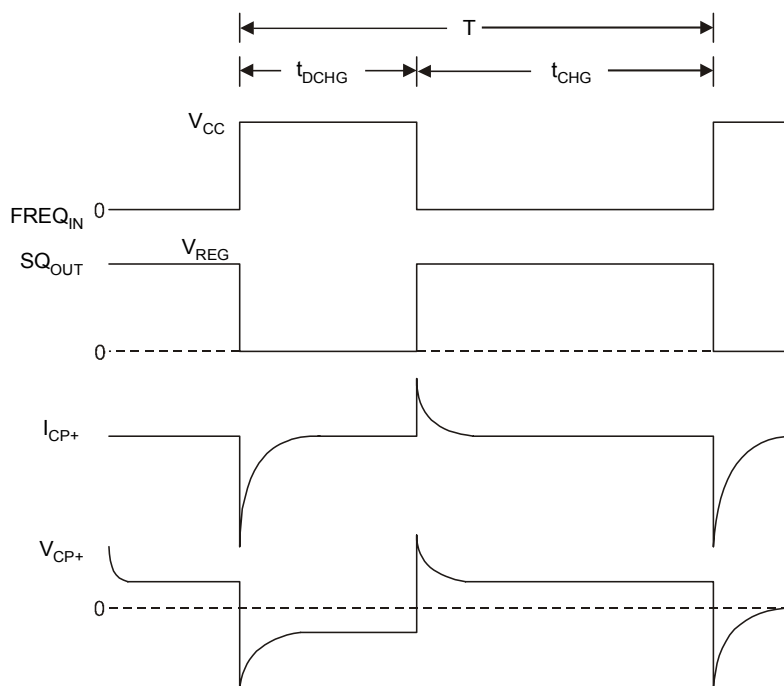

Figure 7. Timing Diagram of $FREQ_{IN}$ and I_{CP}

Ripple voltage on the V/F output causes pointer or needle flutter especially at low input frequencies.

The response time of the V/F is determined by the time constant formed by R_T and C_4 . Increasing the value of C_4 will reduce the ripple on the V/F output but will also increase the response time. An increase in response time causes a very slow meter movement and may be unacceptable for many applications.

The IL8190N has an undervoltage detect circuit that disables the input comparator when V_{CC} falls below 8.0 V (typical). With no input signal the V/F output voltage decreases and the needle moves towards zero. A second undervoltage detect circuit at 6.0 V (typical)

causes the function generator to generate a differential SIN drive voltage of zero volts and the differential COS drive voltage to go as high as possible. This combination of voltages (Figure 1) across the meter coil moves the needle to the 0° position. Connecting a large capacitor ($> 2000 \mu F$) to the V_{CC} lead (C_2 in Figure 8) increases the time between these undervoltage points since the capacitor discharges slowly and ensures that the needle moves towards 0° as opposed to 360° . The exact value of the capacitor depends on the response time of the system, the maximum meter deflection and the current consumption of the circuit. It should be selected by breadboarding the design in the lab.

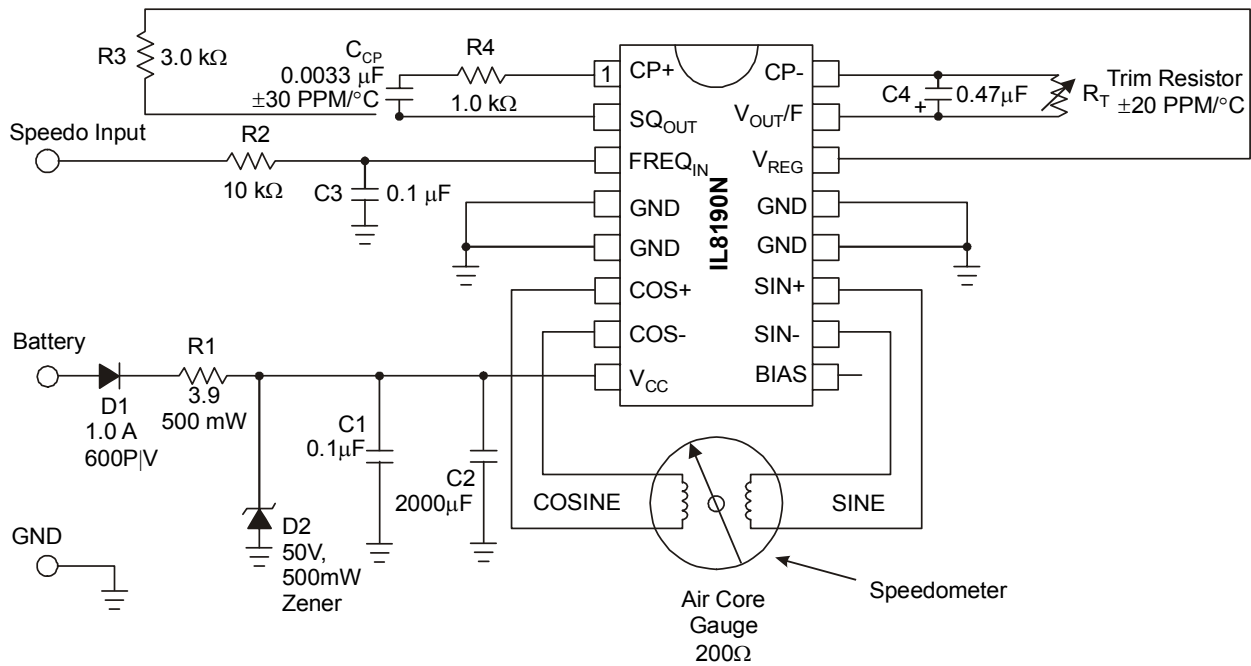

Notes:

1. C2 (> 2000 μF) is needed if return to zero function is required.
2. The product of C4 and R_T have a direct effect on gain and therefore directly affect temperature compensation.
3. C_{cp} Range: 20 pF to 0.2 μF.
4. R4 Range; 100 kΩ to 500 kΩ.
5. The IC must be protected from transients above 60 V and reverse battery conditions.
6. Additional filtering on the FREQ_{IN} lead may be required.
7. Gauge coil connections to the IC must be kept as short as possible (≤ 3.0 inch) for best pointer stability.

Figure 8. Speedometer or Tachometer Application

Design Example

Maximum meter Deflection = 270°
 Maximum Input Frequency = 350 Hz

1. Select R_T and C_{CP}

$$\Theta = 970 \times \text{FREQ} \times C_{CP} \times R_T = 270^\circ$$

Let C_{CP} = 0.0033 μF, find R_T

$$R_T = \frac{270^\circ}{970 \times 350 \text{ Hz} \times 0.0033 \mu\text{F}}$$

$$R_T = 243 \text{ k}\Omega$$

R_T should be a 250 kΩ potentiometer to trim out any inaccuracies due to IC tolerances or meter movement pointer placement.

2. Select R3 and R4

Resistor R3 sets the output current from the voltage regulator. The maximum output current from the voltage regulator is 10 mA. R3 must ensure that the current does not exceed this limit.

Choose R3 = 3.3 kΩ

The charge current for C_{CP} is

$$\frac{V_{REG} - 0.7 \text{ V}}{3.3 \text{ k}\Omega} = 1.90 \text{ mA}$$

C_{CP} must charge and discharge fully during each cycle of the input signal. Time for one cycle at maximum frequency is 2.85 ms. To ensure that C_{CP} is charged, assume that the (R3 + R4) C_{CP} time constant is less than 10% of the minimum input period.

$$T = 10\% \times \frac{1}{350 \text{ Hz}} = 285 \mu\text{s}$$

Choose R4 = 1.0 kΩ.

Discharge time:

$$t_{DCHG} = R3 \times C_{CP} = 3.3 \text{ k}\Omega \times 0.0033 \mu\text{F} = 10.9 \mu\text{s}$$

Charge time:

$$t_{CHG} = (R3 + R4)C_{CP} = 4.3 \text{ k}\Omega \times 0.0033 \mu\text{F} = 14.2 \mu\text{s}$$

3. Determine C4

C4 is selected to satisfy both the maximum allowable ripple voltage and response time of the meter movement.

$$C4 = \frac{C_{CP}(V_{REG} - 0.7\text{V})}{\Delta V_{MAX}}$$

With C4 = 0.47 μF, the V/F ripple voltage is 44 mV.

The last component to be selected is the return to zero capacitor C2. This is selected by increasing the input signal frequency to its maximum so the pointer is at its maximum deflection, then removing the power from the circuit. C2 should be large enough to ensure that

the pointer always returns to the 0° position rather than 360° under all operating conditions.

Figure 11 shows how the IL8190N and the CS8441 are used to produce a Speedometer and Odometer circuit.

In some cases a designer may wish to use the IL8190N only as a driver for an air-core meter having performed the V/F conversion elsewhere in the circuit.

Figure 9 shows how to drive the IL8190N with a DC voltage ranging from 2.0 V to 6.0 V. This is accomplished by forcing a voltage on the V_{OUT}/F lead. The alternative scheme shown in Figure 10 uses an external op amp as a buffer and operates over an input voltage range of 0 V to 4.0 V.

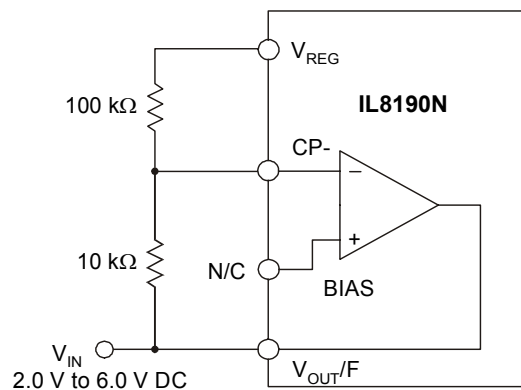

Figure 9. Driving the IL8190N from an External DC Voltage

Figures 9 and 10 are not temperature compensated.

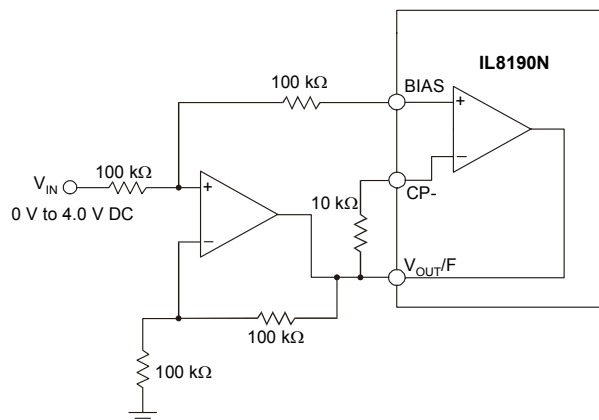
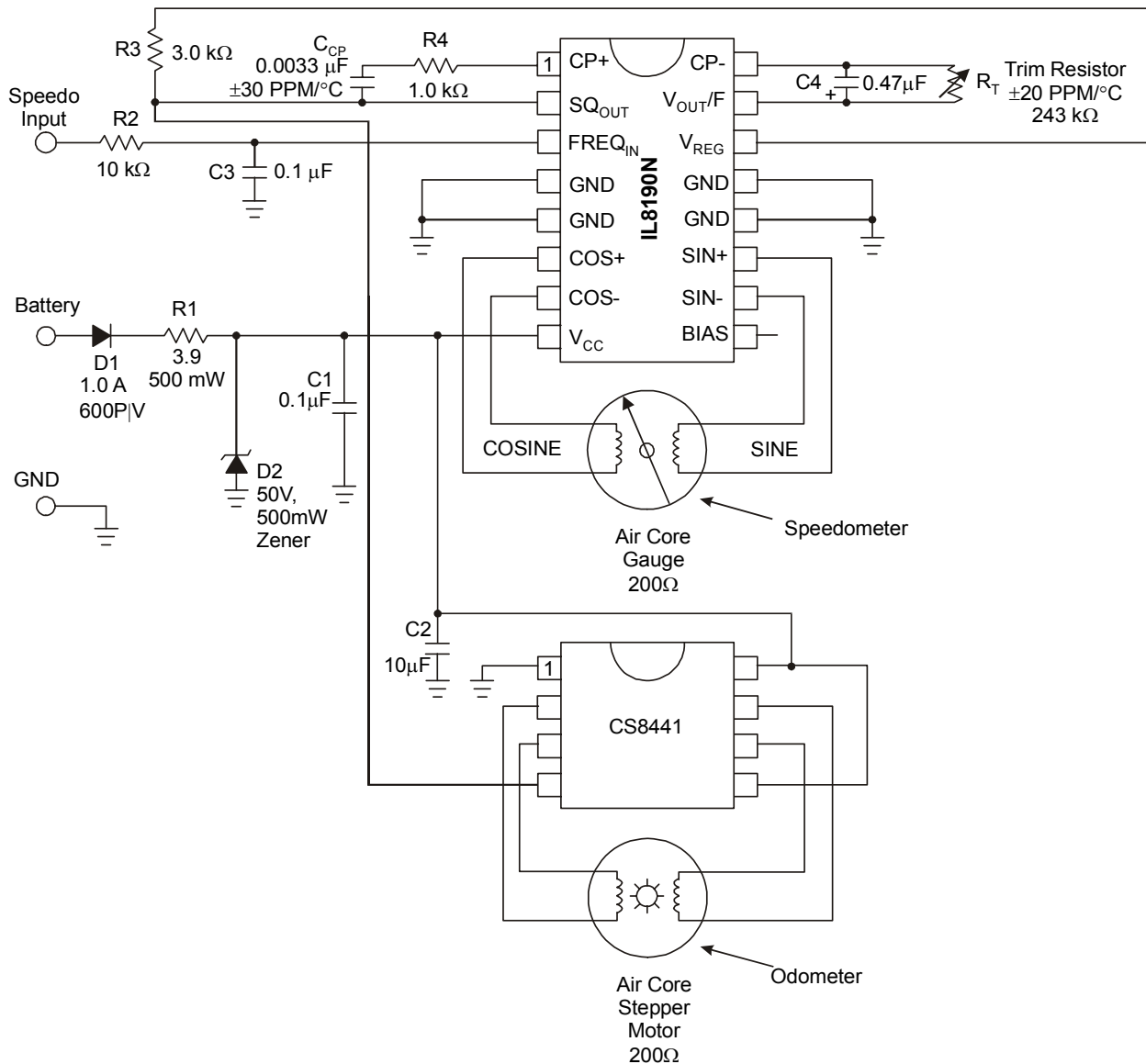

Figure 10. Driving the IL8190N from an External DC Voltage Using an Op Amp Buffer



Notes:

1. C2 = 10 μF with CS8441 application.
2. The product of C4 and R_T have a direct effect on gain and therefore directly affect temperature compensation.
3. Ccp Range: 20 pF to 0.2 μF.
4. R4 Range; 100 kΩ to 500 kΩ.
5. The IC must be protected from transients above 60 V and reverse battery conditions.
6. Additional filtering on the FREQ_{IN} lead may be required.
7. Gauge coil connections to the IC must be kept as short as possible (≤ 3.0 inch) for best pointer stability.

Figure 11. Speedometer With Odometer or Tachometer Application

PACKAGE DIMENSIONS

N SUFFIX PLASTIC
(MS - 001BB)

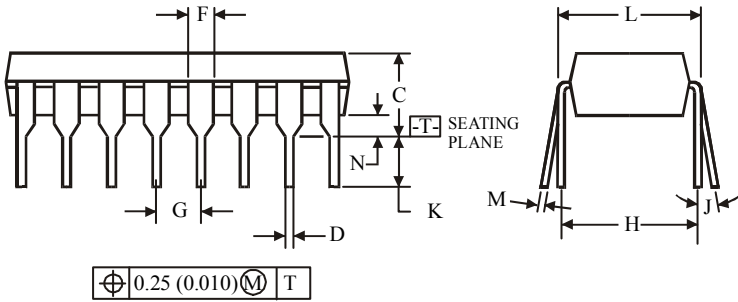
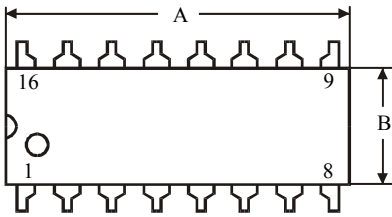
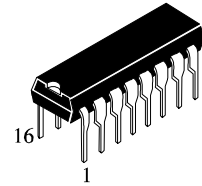

| Symbol | Dimensions, mm | |
|--------|----------------|-------|
| | MIN | MAX |
| A | 18.67 | 19.69 |
| B | 6.10 | 7.11 |
| C | | 5.33 |
| D | 0.36 | 0.56 |
| F | 1.14 | 1.78 |
| G | 2.54 | |
| H | 7.62 | |
| J | 0° | 10° |
| K | 2.92 | 3.81 |
| L | 7.62 | 8.26 |
| M | 0.20 | 0.36 |
| N | 0.38 | |

NOTES:

- Dimensions "A", "B" do not include mold flash or protrusions.
Maximum mold flash or protrusions 0.25 mm (0.010) per side.