

SMD Type Transistors

PNP Epitaxial Planar Silicon Transistor
2SA1257

■ Features

- High breakdown voltage.
- Small output capacitance.

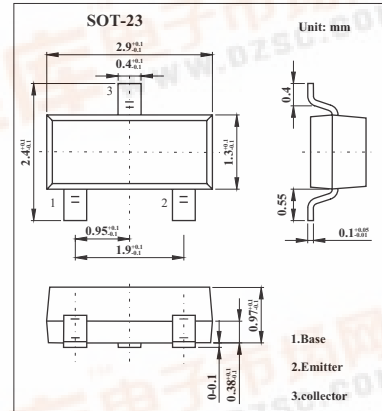

■ Absolute Maximum Ratings Ta = 25°C

Parameter	Symbol	Rating	Unit
Collector-base voltage	V _{CB0}	-180	V
Collector-emitter voltage	V _{CE0}	-160	V
Emitter-base voltage	V _{EB0}	-5	V
Collector current	I _c	-80	mA
Collector current (pulse)	I _{cP}	-150	mA
Collector dissipation	P _c	200	mW
Junction temperature	T _j	125	°C
Storage temperature	T _{stg}	-55 to +125	°C

2SA1257

■ Electrical Characteristics Ta = 25°C

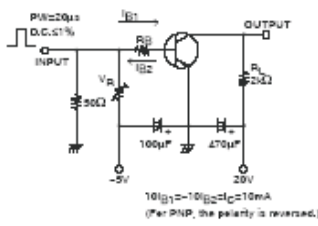
Parameter	Symbol	Testconditions	Min	Typ	Max	Unit	
Collector cutoff current	I _{CBO}	V _{CB} = -120V , I _E = 0			-0.1	μA	
Emitter cutoff current	I _{EBO}	V _{EB} = -4V , I _C = 0			-0.1	μA	
DC current Gain	h _{FE}	V _{CE} = -5V , I _C = -10 mA	60		270		
Gain bandwidth product	f _T	V _{CE} = -10V , I _C = -10 mA		130		MHz	
Output capacitance	C _{ob}	V _{CB} = -10V , f = 1MHz		2.4	3.2	pF	
Base-emitter voltage	V _{BE}	V _{CE} = -5V , I _C = -10 mA			-1.5	V	
Collector-emitter saturation voltage	V _{CE(sat)}	I _C = -30mA , I _B = -3mA			-0.7	V	
Collector-to-base breakdown voltage	V _{(BR)CBO}	I _C = -10μA , I _E = 0	-180			V	
Collector-to-emitter breakdown voltage	V _{(BR)CEO}	I _C = -1mA , R _{BE} = ∞	-160			V	
Emitter-base breakdown voltage	V _{(BR)EBO}	I _E = -10μA , I _C = 0	-5			V	
Turn-on time	t _{on}			0.15		μs	
Storage time	t _{stg}				0.95		μs
Fall time	t _f				0.15		μs

■ hFE Classification

Rank	G3	G4	G5
hFE	60~120	90~180	135~270