

SMD Type Transistors

NPN Epitaxial Planar Silicon Transistor  
2SC4399

Features

- High power gain : PG=25dB typ (f=100MHz).
- applied sets to be made small and slim.

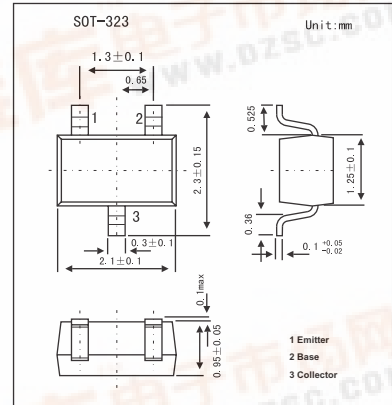

Absolute Maximum Ratings Ta = 25°C

Parameter	Symbol	Rating	Unit
Collector-base voltage	V <sub>CB0</sub>	30	V
Collector-emitter voltage	V <sub>CEO</sub>	20	V
Emitter-base voltage	V <sub>EBO</sub>	5	V
Collector current	I <sub>c</sub>	30	mA
Collector dissipation	P <sub>c</sub>	150	mW
Junction temperature	T <sub>j</sub>	150	°C
Storage temperature	T <sub>stg</sub>	-55 to +150	°C

Electrical Characteristics Ta = 25°C

Parameter	Symbol	Testconditions	Min	Typ	Max	Unit
Collector cutoff current	I <sub>cBO</sub>	V <sub>CB</sub> = 10V, I <sub>E</sub> =0			0.1	μA
Emitter cutoff current	I <sub>EBO</sub>	V <sub>EB</sub> = 4V, I <sub>C</sub> =0			0.1	μA
DC current gain	h <sub>FE</sub>	V <sub>CE</sub> = 6V, I <sub>c</sub> = 1mA	60		270	
Gain bandwidth product	f <sub>T</sub>	V <sub>CE</sub> = 6V, I <sub>c</sub> = 1mA	200	320		MHz
Reverse transfer capacitance	C <sub>re</sub>	V <sub>CB</sub> = 6V, f = 1MHz		0.9	1.2	pF
Base-collector time constant	r <sub>bb'</sub> C <sub>c</sub>	V <sub>CB</sub> = 6V, I <sub>c</sub> = 1mA, f = 31.9MHz		12	20	ps
Power gain	PG	V <sub>CB</sub> = 6V, I <sub>c</sub> = 1mA, f = 100MHz		25		dB
Noise figure	NF	V <sub>CB</sub> = 6V, I <sub>c</sub> = 1mA, f = 100MHz		3.0		dB

hFE Classification

Marking	F		
Rank	3	4	5
hFE	60~120	90~180	135~270

