

SMD Type Transistors

Silicon NPN Triple Diffused Type Transistor
2SC4616

■ Features

- Large current calcity ($I_c=2A$)
- High blocking voltage ($V_{CE0} \geq 400V$)

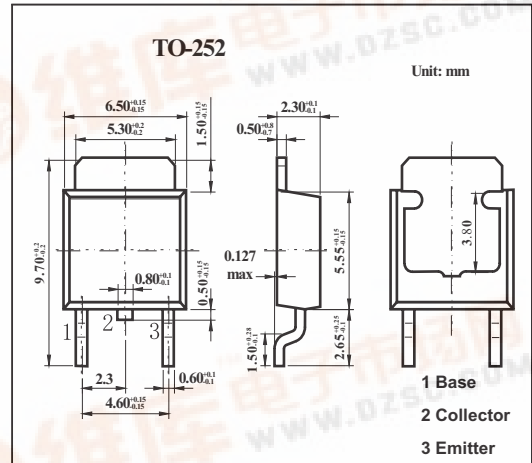

■ Absolute Maximum Ratings $T_a = 25^\circ C$

Parameter	Symbol	Rating	Unit
Collector to base voltage	V_{CBO}	400	V
Collector to emitter voltage	V_{CEO}	400	V
Emitter to base voltage	V_{EBO}	5	V
Peak collector current	I_{CP}	4	A
Collector current	I_C	2	A
Collector power dissipation $TC=25^\circ C$	P_C	1	W
		15	W
Junction temperature	T_j	150	$^\circ C$
Storage temperature	T_{stg}	-55 to +150	$^\circ C$

2SC4616

■ Electrical Characteristics Ta = 25°C

Parameter	Symbol	Testconditions	Min	Typ	Max	Unit
Collector cut-off Current	I _{CBO}	V _{CB} =300V, I _E =0			1	μA
Emitter Cut-off Current	I _{EBO}	V _{EB} =4V, I _C =0			1	μA
DC Current Gain	h _{FE}	V _{CE} =10V, I _C =100mA	40		200	
Gain-Bandwidth product	f _T	V _{CE} =10V, I _C =100mA		60		MHz
C-E Saturation Voltage	V _{CE(sat)}	I _C =500mA, I _B =50mA			1	V
B-E Saturation Voltage	V _{BE(sat)}	I _C =500mA, I _B =50mA			1	V
C-B Breakdown Voltage	V _{(BR)CBO}	I _C =10μA, I _E =0	400			V
C-E Breakdown Voltage	V _{(BR)CEO}	I _C =1mA, R _{BE} =∞	400			V
E-B Breakdown Voltage	V _{(BR)EBO}	I _E =10μA, I _C =0	5			V
Output capacitance	c _{ob}	V _{CB} =30V, f=1MHz		15		pF
Turn-ON Time	t _{on}	<p>PW = 20μs DC ≤ 1% V_{BE} = 5V V_{CE} = 150V 10I_{B1} = -10I_{B2} = I_C = 500mA R_C = 300Ω, R_B = 20Ω, at I_C = 500mA</p>		0.085	μs	
Storage Time	t _{stg}			4		
Fall Time	t _r			0.6		

■ hFE Classification

TYPE	C	D	E
hFE	40 to 80	60 to 120	100 to 200