

SMD Type Transistors

PNP Silicon Extremely High Voltage
Darlington Transistor
CZT2000

Features

-

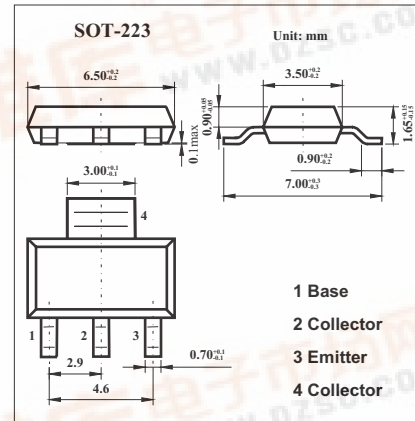

Absolute Maximum Ratings Ta = 25°C

Parameter	Symbol	Rating	Unit
Collector-Base Voltage	V _{CB0}	200	V
Collector-Emitter Voltage	V _{CEO}	200	V
Emitter-Base Voltage	V _{EBO}	10	V
Collector Current	I _C	600	mA
Power Dissipation	P _D	2	W
Operating and Storage Junction Temperature	T _J , T _{stg}	-65 to 150	°C
Thermal Resistance	Θ _{JA}	62.5	°C/W

Electrical Characteristics Ta = 25°C

Symbol	Testconditions	Min	Max	Unit
I _{CBO}	V _{CB} =180V		500	nA
I _{EBO}	V _{BE} =10V		100	nA
B _V CE _S	I _C =1.0mA	200		V
V _{CE(SAT)}	I _C =20mA, I _B =25μA		0.9	V
V _{CE(SAT)}	I _C =80mA, I _B =40μA		1.1	V
V _{CE(SAT)}	I _C =160mA, I _B =100μA		1.2	V
V _{BE(ON)}	V _{CE} =5.0V, I _C =160mA		2.0	V
h _{FE}	V _{CE} =5.0V, I _C =100μA	3,000		
	V _{CE} =5.0V, I _C =10mA	3,000		
	V _{CE} =5.0V, I _C =160mA	3,000		