



LT1935

1.2MHz Boost DC/DC Converter in ThinSOT with 2A Switch

FEATURES

- 1.2MHz Switching Frequency
- High Output Voltage: Up to 38V
- Wide Input Range: 2.3V to 16V
- Low V_{CESAT} Switch: 180mV at 2A
- Soft-Start
- Uses Small Surface Mount Components
- 5V at 1A from 3.3V Input
- 12V at 600mA from 5V Input
- Low Shutdown Current: $<1\mu A$
- Pin-for-Pin Compatible with the LT1613 and LT1930
- Low Profile (1mm) SOT-23 (ThinSOT™) Package

APPLICATIONS

- Digital Cameras
- Battery Backup
- LCD Bias
- Local 5V or 12V Supply
- PC Cards
- xDSL Power Supply
- TFT-LCD Bias Supply

DESCRIPTION

The LT[®]1935 is the industry's highest power SOT-23 switching regulator. Its unprecedented 2A, 40V internal switch allows high output currents to be generated in a small footprint. Intended for space-conscious applications, the LT1935 switches at 1.2MHz, allowing the use of tiny, low profile inductors and capacitors 2mm or less in height. The NPN switch achieves a V_{CESAT} of just 180mV at 2A independent of supply voltage, resulting in high efficiency even at maximum power levels from a 3V input.

A constant frequency, internally compensated, current mode PWM architecture results in low, predictable output noise that is easy to filter. Low ESR ceramic capacitors can be used on the output, further reducing noise to the millivolt level. The high voltage switch on the LT1935 is rated at 40V, making the device ideal for boost converters up to 38V as well as for single-ended primary inductance converter (SEPIC) and flyback designs. The device can generate 5V at up to 1A from a 3.3V supply or 5V at 550mA from four alkaline cells in a SEPIC design.

The LT1935 is available in a 5-lead SOT-23 package.

LT, LTC and LT are registered trademarks of Linear Technology Corporation. ThinSOT is a trademark of Linear Technology Corporation.

TYPICAL APPLICATION

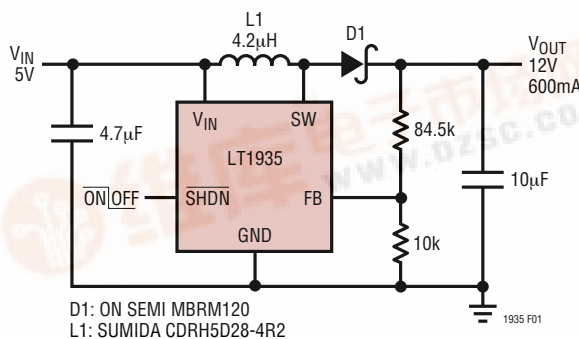
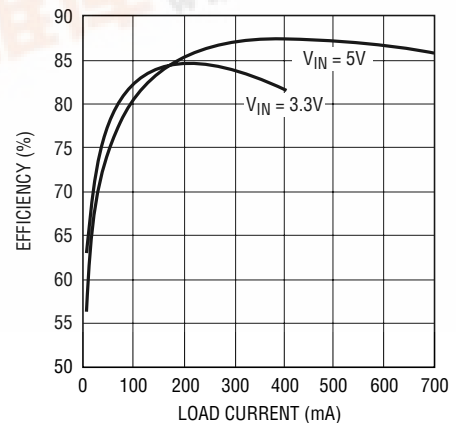

Figure 1. 5V to 12V, 600mA Step-Up DC/DC Converter

Efficiency, $V_{OUT} = 12V$



1935 F01b

LT1935

ABSOLUTE MAXIMUM RATINGS

(Note 1)

V_{IN} Voltage	16V
SW Voltage	-0.4V to 40V
FB Voltage	6V
Current Into FB Pin	± 1 mA
SHDN Voltage	16V
Maximum Junction Temperature	125°C
Operating Ambient Temperature Range	
(Note 2)	-40°C to 85°C
Storage Temperature Range	-65°C to 150°C
Strict adherence to JEDEC 020B solder attach and rework for assemblies containing lead is recommended.	

PACKAGE/ORDER INFORMATION

	ORDER PART NUMBER
	LT1935ES5
	S5 PART MARKING
	LTRX

Consult LTC marketing for parts specified with wider operating temperature ranges.

ELECTRICAL CHARACTERISTICS

The ● denotes specifications which apply over the full operating temperature range, otherwise specifications are $T_A = 25^\circ\text{C}$. $V_{IN} = 3\text{V}$, $V_{SHDN} = V_{IN}$ unless otherwise noted. (Note 2)

PARAMETER	CONDITIONS	MIN	TYP	MAX	UNITS
Feedback Voltage	Measured at the FB Pin ●	1.240	1.265	1.280	V
Feedback Voltage Line Regulation	$2.5\text{V} \leq V_{IN} \leq 16\text{V}$		0.01		%/V
FB Pin Bias Current	$V_{FB} = V_{REF}$ ●		12	60	nA
Undervoltage Lockout Threshold			2.1	2.3	V
Maximum Input Voltage				16	V
Switching Frequency		1	1.2	1.4	MHz
Maximum Duty Cycle	●	85	93		%
Switch Current Limit	(Note 3)	2	3.2		A
Switch Saturating Voltage	$I_{SW} = 2\text{A}$		180	280	mV
Switch Leakage Current	$V_{SW} = 5\text{V}$ ●		0.01	1	μA
SHDN Pin Input Current	$V_{SHDN} = 1.8\text{V}$		14	40	μA
	$V_{SHDN} = 0\text{V}$			0.1	μA
Operating Supply Current	$V_{FB} = 1.5\text{V}$		3		mA
SHDN Supply Current	$V_{SHDN} = 0\text{V}$		0.1	1	μA
SHDN Input High Voltage		1.8			V
SHDN Input Low Voltage				0.5	V

Note 1: Absolute Maximum Ratings are those values beyond which the life of a device may be impaired.

Note 2: The LT1935ES5 is guaranteed to meet performance specifications from 0°C to 70°C. Specifications over the -40°C to 85°C operating

temperature range are assured by design, characterization and correlation with statistical process controls.

Note 3: Current limit guaranteed by design and/or correlation to static test.

TYPICAL PERFORMANCE CHARACTERISTICS

FB Pin Voltage

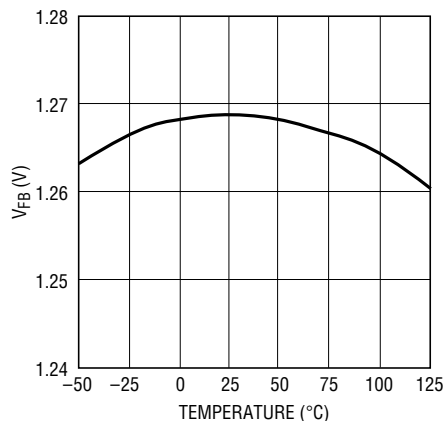

1935 G01

Oscillator Frequency

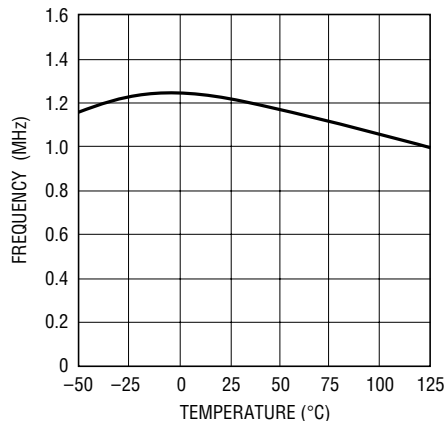

1935 G02

Undervoltage Lockout

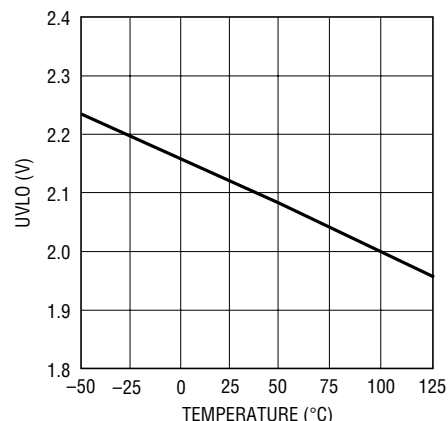

1935 G03

Current Limit

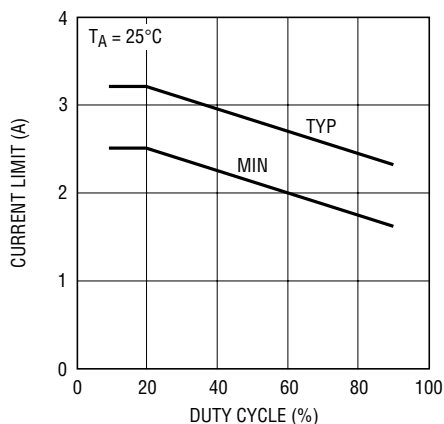

1935 G04

Switch Saturation Voltage

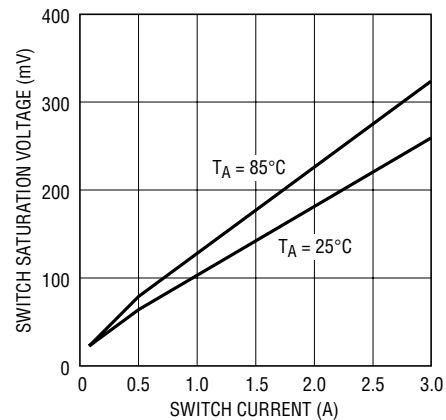

1935 G05

Peak Switch Current vs $\overline{\text{SHDN}}$ Pin Voltage (Soft-Start)

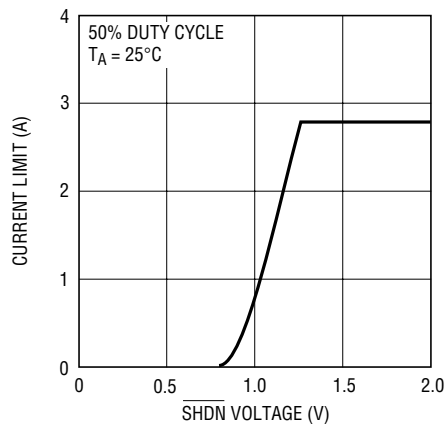

1935 G06

$\overline{\text{SHDN}}$ Pin Current

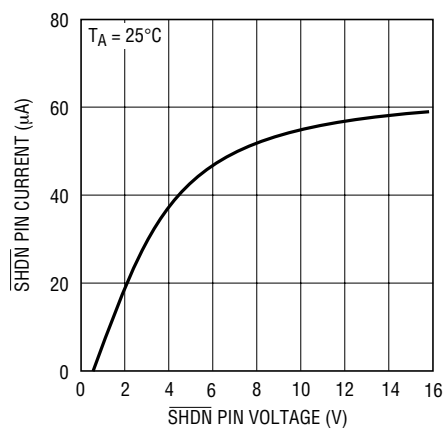

1935 G07

Frequency Foldback

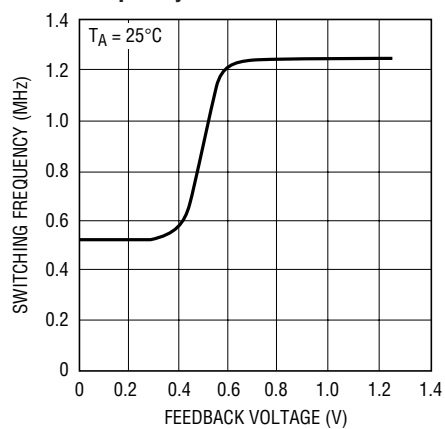

1935 G08

PIN FUNCTIONS

SW (Pin 1): Switch Pin. Connect inductor/diode here. Minimize trace area at this pin to reduce EMI.

GND (Pin 2): Ground. Tie directly to local ground plane.

FB (Pin 3): Feedback Pin. Reference voltage is 1.265V. Connect resistive divider tap here. Minimize trace area at FB. Set V_{OUT} according to $V_{OUT} = 1.265V(1 + R1/R2)$.

SHDN (Pin 4): Shutdown Pin. Tie to 1.8V or more to enable device. Ground to shut down. This pin also provides a soft-start function; see Applications Information section.

V_{IN} (Pin 5): Input Supply Pin. Must be locally bypassed.

BLOCK DIAGRAM

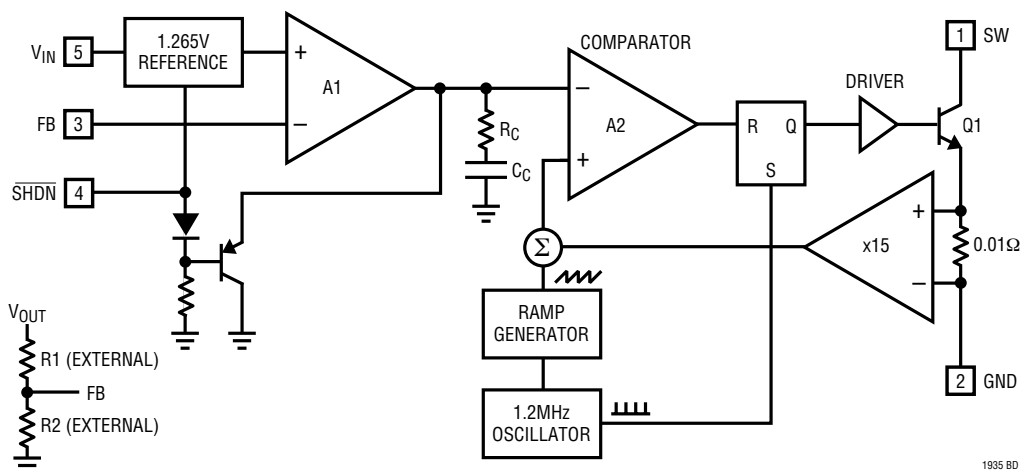

Figure 2. Block Diagram

OPERATION

The LT1935 uses a constant frequency, current mode control scheme to provide excellent line and load regulation. Operation can be best understood by referring to the Block Diagram in Figure 2. At the start of each oscillator cycle, the SR latch is set, turning on the power switch Q1. A voltage proportional to the switch current is added to a stabilizing ramp and the resulting sum is fed into the positive terminal of the PWM comparator, A2. When this voltage exceeds the level at the negative input of A2, the SR latch is reset, turning off the power switch. The level at the negative input of A2 is set by error amplifier A1, and

is simply an amplified version of the difference between the feedback voltage and the reference voltage of 1.265V. In this manner, the error amplifier sets the correct peak current level to keep the output in regulation. If the error amplifier's output increases, more current is delivered to the output; if it decreases, less current is delivered. A clamp on the output of A1 (not shown) limits the switch current to 3A. A1's output is also clamped to the voltage on the SHDN pin, providing a soft-start function by controlling the peak switch current during start-up.

APPLICATIONS INFORMATION

Inductor Selection

Use inductors that are intended for high frequency power applications. The saturation current rating should be at least 2A. The RMS current rating, which is usually based on heating of the inductor, should be higher than the average current in the inductor in your application. For best efficiency, the DC resistance should be less than 100mΩ.

A good first choice for the inductor value results in a ripple current that is 1/3 of the maximum switch current:

$$L = 3 (V_{IN}/V_{OUT}) (V_{OUT} - V_{IN}) / (I_{MAX} \cdot f)$$

I_{MAX} is the maximum switch current of 2A and f is the switching frequency. At lower duty cycles (less than 70%), this value can be lowered somewhat in order to use a physically smaller inductor.

Table 1 lists several inductor manufacturers, along with part numbers for inductors that are a good match to the LT1935.

Table 1. Inductor Suppliers

Supplier	Model Prefix
Sumida	CDRH4D18, CDRH4D28, CDRH5D18, CDRH5D28, CR43
Coiltronics/Cooper	SD10, SD12, SD18, SD20
Würth Elektronik	WE-PD2S, WE-PD3S, WE-PD4S
Coilcraft	MSS5131, MSS6132, D01608

Diode Selection

Use a Schottky rectifier with a 1A or higher current rating, such as the On Semiconductor MBRM120. Its 20V reverse voltage rating is adequate for most applications. Higher output voltages may require a 30V or 40V diode.

Capacitor Selection

Use capacitors with low ESR (equivalent series resistance). In most cases, multilayer ceramic capacitors are the best choice. They offer high performance (very low ESR) in a small package. Use only X5R or X7R types; they maintain their capacitance over temperature and applied voltage. Other suitable capacitor types include low-ESR tantalum capacitors that are specified for power applications, and newer types of capacitors such as Sanyo's POSCAP and Panasonic's SP CAP.

Use a 4.7μF ceramic capacitor to bypass the input of the LT1935. Be aware that the switching regulators require a low impedance input supply. Additional bulk capacitance may be required if the LT1935 circuit is more than a few inches away from the power source. If there are low ESR capacitors nearby, the input bypass capacitor can be reduced to 2.2μF.

The output capacitor supports the output under transient loads and stabilizes the control loop of the LT1935. Look at the typical application circuits as a starting point to choose a value. Generally, a higher output capacitance is required at higher load currents and lower input voltages.

Figure 3 shows transient response of the circuit in Figure 1. The load is stepped from 200mA to 400mA and back to 200mA. The transient performance can be improved by increasing the output capacitance, but may require a phase lead capacitor between the output and the FB pin. Figure 4 shows the transient response with the output capacitor increased to 20μF. Figure 5 shows the additional improvement resulting from the phase lead capacitor.

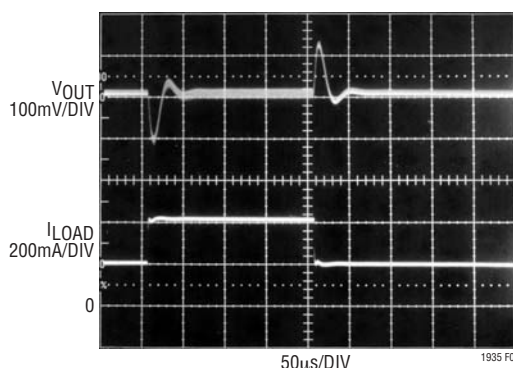

Figure 3. Transient Response of the Circuit in Figure 1, $C_{OUT} = 10\mu F$

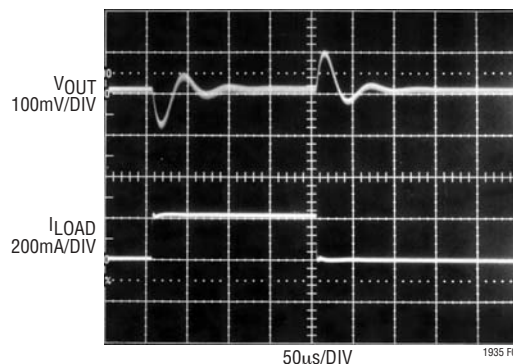

Figure 4. Transient Response with $C_{OUT} = 20\mu F$

APPLICATIONS INFORMATION

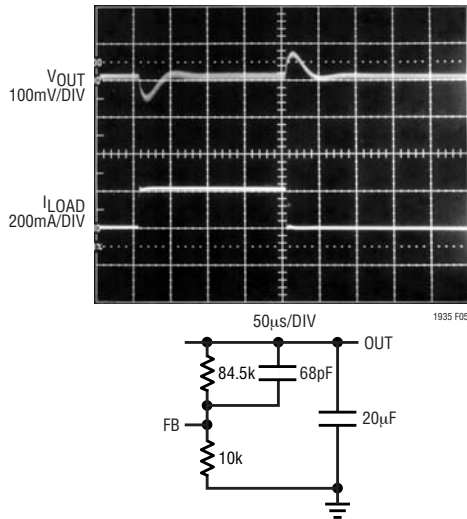

Figure 5. Transient Response with a 68pF Phase-Lead Capacitor

Soft Start

The $\overline{\text{SHDN}}$ pin can be used to soft start the LT1935, reducing the maximum input current during start up. The $\overline{\text{SHDN}}$ pin is driven through an external RC filter to create a ramp at this pin. Figure 6 shows the start-up waveforms with and without the soft start circuit. Without soft start, the input current peaks at $\sim 3\text{A}$. With soft start, the peak current is reduced to 1A. By choosing a large RC time constant, the peak start-up current can be reduced to the current that is required to regulate the output, with no overshoot. Choose the value of the resistor so that it can supply $100\mu\text{A}$ when the $\overline{\text{SHDN}}$ pin reaches 1.8V.

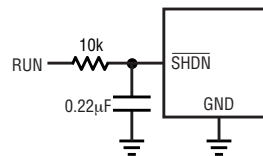
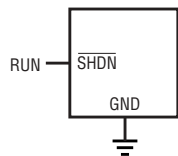
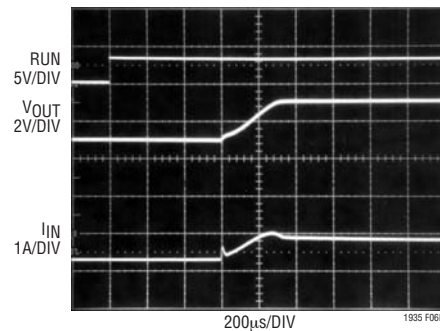
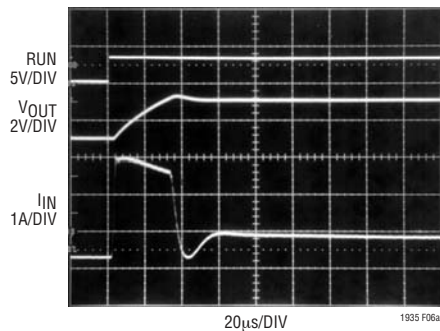

Figure 6. Adding a Resistor and Capacitor to the $\overline{\text{SHDN}}$ Pin Reduces the Peak Input Current During Start-Up. $V_{\text{IN}} = 3.3\text{V}$, $V_{\text{OUT}} = 5\text{V}$, $C_2 = 20\mu\text{F}$, Output Load = 10Ω .

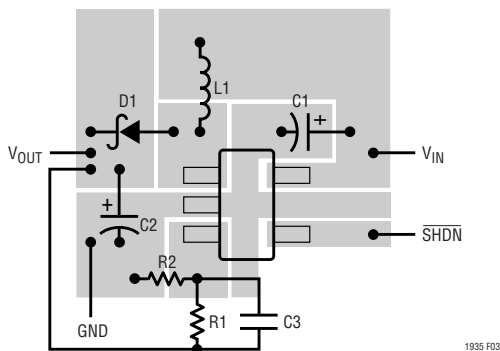
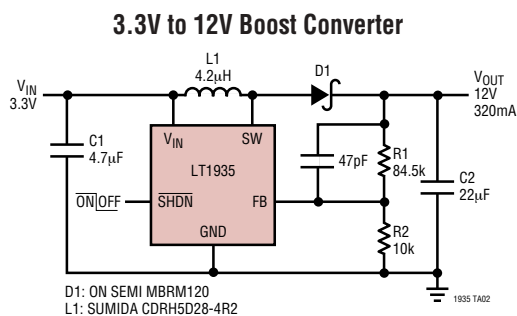
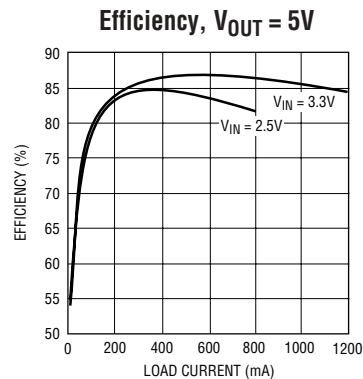
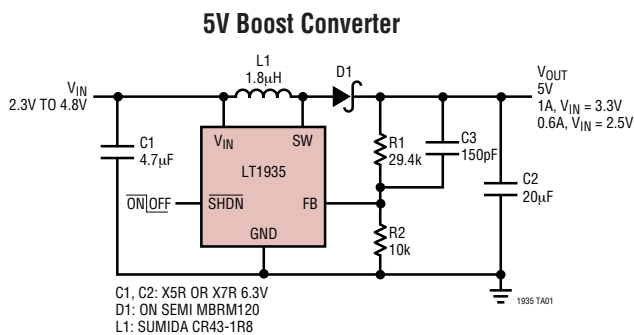

Figure 7. Suggested Layout

Layout Hints

The high speed operation of the LT1935 demands careful attention to board layout. You will not get advertised performance with careless layout. Figure 7 shows the recommended component placement. Make the ground pin copper area large. This helps to lower the die temperature.

TYPICAL APPLICATIONS



PACKAGE DESCRIPTION

S5 Package
5-Lead Plastic TSOT-23
 (Reference LTC DWG # 05-08-1635)

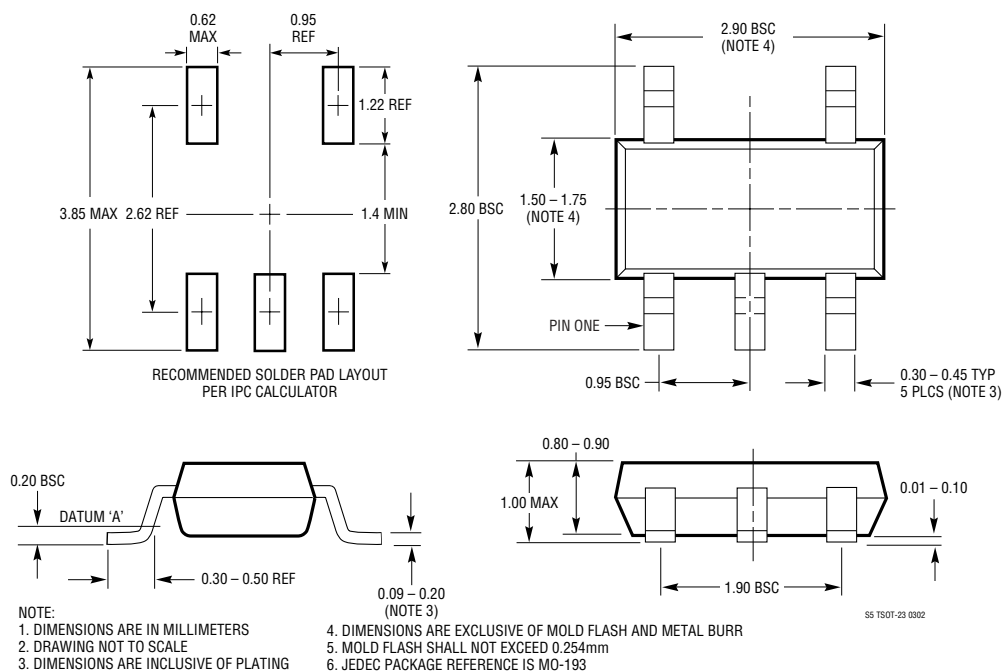

TYPICAL APPLICATIONS

8V, 16V and -8V TFT LCD Power Supply

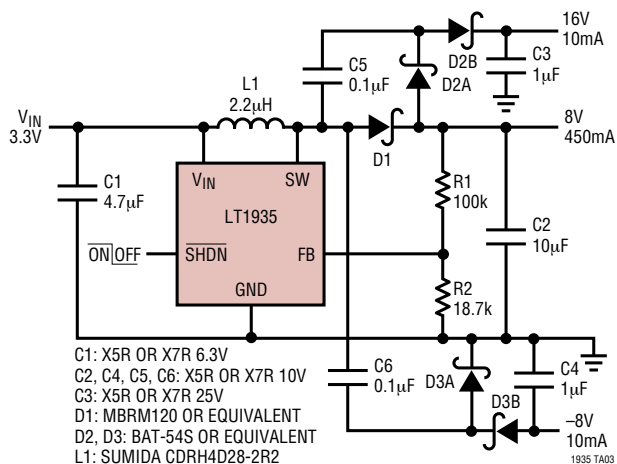

5V SEPIC Converter

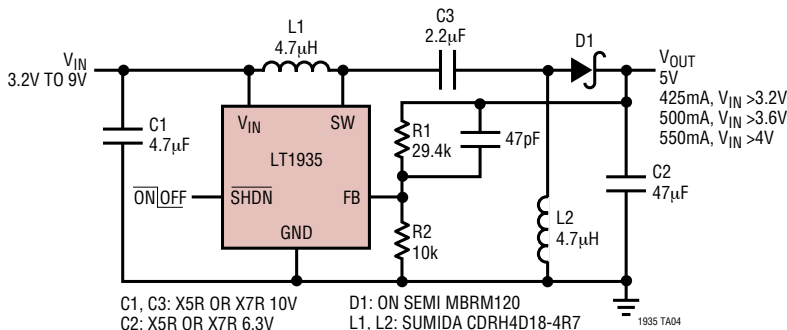

RELATED PARTS

PART NUMBER	DESCRIPTION	COMMENTS
LT1618	1.5A (I_{SW}), 1.25MHz, High Efficiency Step-Up DC/DC Converter	V_{IN} : 1.6V to 18V, $V_{OUT(MAX)}$: 35V, I_Q : 1.8mA, I_{SD} : <1µA, MS, DFN Packages
LT1930/LT1930A	1A (I_{SW}), 1.2MHz/2.2MHz, High Efficiency Step-Up DC/DC Converter	V_{IN} : 2.6V to 16V, $V_{OUT(MAX)}$: 34V, I_Q : 4.2mA/5.5mA I_{SD} : <1µA, ThinSOT Package
LT1943	Quad Output, 2.6A Buck, 2.6A Boost, 0.3A Boost, 0.4A Inverter 1.2MHz TFT DC/DC Converter	V_{IN} : 4.5V to 22V, $V_{OUT(MAX)}$: 40V, I_Q : 10mA, I_{SD} : <35µA, TSSOP-28E Package
LT1946/LT1946A	1.5A (I_{SW}), 1.2MHz/2.7MHz, High Efficiency Step-Up DC/DC Converter	V_{IN} : 2.45V to 16V, $V_{OUT(MAX)}$: 34V, I_Q : 3.2mA, I_{SD} : <1µA, MS8 Package
LTC3400/LTC3400B	600mA (I_{SW}), 1.2MHz, Synchronous Step-Up DC/DC Converter	V_{IN} : 0.85V to 5V, $V_{OUT(MAX)}$: 5V, I_Q : 19µA/300µA I_{SD} : <1µA, ThinSOT Package
LTC3401/LT3402	1A/2A(I_{SW}), 3MHz, Synchronous Step-Up DC/DC Converter	V_{IN} : 0.5V to 5V, $V_{OUT(MAX)}$: 6V, I_Q : 38µA, I_{SD} : <1µA, MS Package
LTC3425	5A (I_{SW}), 8MHz, Multi-Phase Synchronous Step-Up DC/DC Converter	V_{IN} : 0.5V to 4.5V, $V_{OUT(MAX)}$: 5.25V, I_Q : 12µA, I_{SD} : <1µA, QFN Package
LT3436	3A (I_{SW}), 1MHz, 34V Step-Up DC/DC Converter	V_{IN} : 3V to 25V, $V_{OUT(MAX)}$: 34V, I_Q : 0.9mA, I_{SD} : <6µA, TSSOP-16E Package
LT3467/LT3467A	1.1A (I_{SW}), 1.3MHz/2.1MHz, High Efficiency Step-Up DC/DC Converter	V_{IN} : 2.6V to 16V, $V_{OUT(MAX)}$: 40V, I_Q : 1.2mA, I_{SD} : <1µA, ThinSOT Package