

SMD Type Transistors

PNP Medium Power Transistor
BCP69

■ Features

- High current.
- Three current gain selections.
- 1.4 W total power dissipation.

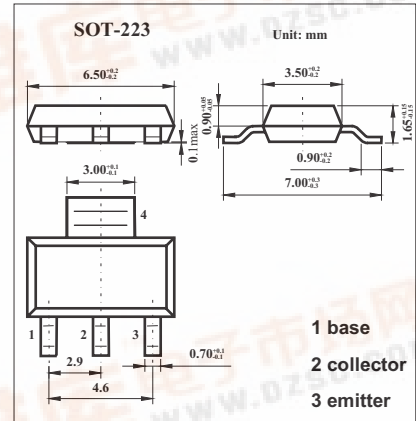

■ Absolute Maximum Ratings Ta = 25°C

Parameter	Symbol	Rating	Unit
Collector-base voltage	V _{CB0}	-32	V
Collector-emitter voltage	V _{CE0}	-20	V
Emitter-base voltage	V _{EB0}	-5	V
Collector current (DC)	I _C	-1	A
Peak collector current	I _{CM}	-2	A
Peak base current	I _{BM}	-200	mA
Total power dissipation	P _{tot}	* 1	0.625 W
		* 2	1 W
		* 3	1.4 W
Storage temperature	T _{stg}	-65 to +150	°C
Junction temperature	T _j	150	°C
Operating ambient temperature	T _{amb}	-65 to +150	°C
Thermal resistance from junction to ambient *	R _{th(j-a)}	* 1	200 K/W
		* 2	125 K/W
		* 3	89 K/W
Thermal resistance from junction to solder point	R _{th(j-s)}	15	K/W

*1 Device mounted on a FR4 PCB; single-sided copper; tinplated; standard footprint for SOT223.

*2 Device mounted on a FR4 PCB; single-sided copper; tinplated; 1 cm² collector mounting pad.

*3 Device mounted on a FR4 PCB; single-sided copper; tinplated; 6 cm² collector mounting pad.

BCP69■ Electrical Characteristics $T_a = 25^\circ\text{C}$

Parameter	Symbol	Testconditions	Min	Typ	Max	Unit
Collector cutoff current	I _{CBO}	I _E = 0 A; V _{CB} = -25 V			-100	nA
		I _E = 0 A; V _{CB} = -25 V; T _j = 150 °C			-10	μA
Emitter cutoff current	I _{EBO}	I _C = 0 A; V _{EB} = -5 V			-100	nA
DC current gain	BCP69	V _{CE} = -10 V; I _C = -5 mA	50			
		V _{CE} = -1 V; I _C = -500 mA	85		375	
	hFE	V _{CE} = -1 V; I _C = -1 A	60			
		BCP69-16		100		250
		BCP69-16/IN		140		230
		BCP69-25		160		375
Collector-emitter saturation voltage	V _{CEsat}	I _C = -1 A; I _B = -100 mA;			-500	mV
Base-emitter voltage	V _{BE}	V _{CE} = -10 V; I _C = -5 mA			-700	mV
		V _{CE} = -1 V; I _C = -1 A			-1	V
Collector capacitance	C _c	I _E = I _E = 0 A; V _{CB} = -10 V; f = 1 MHz		28		pF
Transition frequency	f _T	I _C = -50 mA; V _{CE} = -5 V; f = 100 MHz	40	140		MHz

■ hFE Classification

TYPE	BCP69	BCP69-16	BCP69-16/IN	BCP69-25
Marking	BCP69	BCP69/16	69-16N	BCP69/25