



1.1MHz, 1A Switch PWM DC/DC Converter

June 2000

NOT RECOMMENDED FOR NEW DESIGNS
Contact Linear Technology for Potential Replacement

FEATURES

- 1A, 0.5Ω, 30V Internal Switch
- 1.1MHz Fixed Frequency Operation
- Operates with V_{IN} as Low as 1.5V
- Low-Battery Detector Stays Active in Shutdown
- Low V_{CESAT} Switch: 410mV at 800mA
- Pin-for-Pin Compatible with the LT1317B
- Uses Ceramic Capacitors
- Small 8-Lead MSOP Package

APPLICATIONS

- LCD Bias Supplies
- GPS Receivers
- Battery Backup
- Portable Electronic Equipment
- Diagnostic Medical Instrumentation

DESCRIPTION

The LT[®]1949-1 is a fixed frequency step-up DC/DC converter with a 1A, 0.5Ω internal switch. Capable of generating 10V at 175mA from a 3.3V input, the LT1949-1 is ideal for generating bias voltages for large screen LCD panels. Constant frequency 1.1MHz operation results in a low noise output that is easy to filter and the 30V switch rating allows output voltage up to 28V using a single inductor. The high switching frequency allows the use of ceramic output capacitors. An external compensation pin gives the user flexibility in optimizing loop compensation, allowing small, low ESR ceramic capacitors to be used at the output. The 8-lead MSOP package ensures a low profile overall solution.

The LT1949-1 includes a low-battery detector that stays alive when the device goes into shutdown. Quiescent current in shutdown is 50μA, while operating current is 8mA.

LT, LTC and LT are registered trademarks of Linear Technology Corporation.

TYPICAL APPLICATION

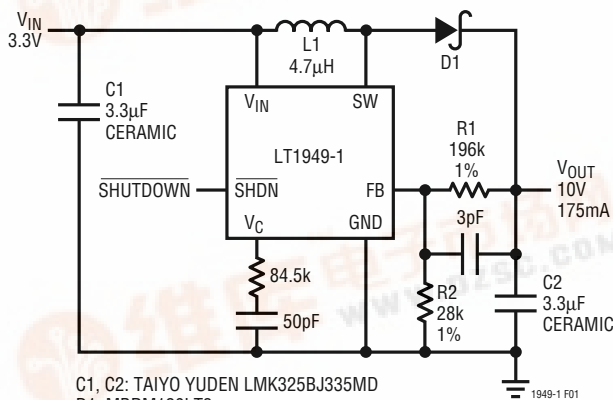

C1, C2: TAIYO YUDEN LMK325BJ335MD
D1: MBRM120LT3
L1: SUMIDA CLQ4D10-4R7

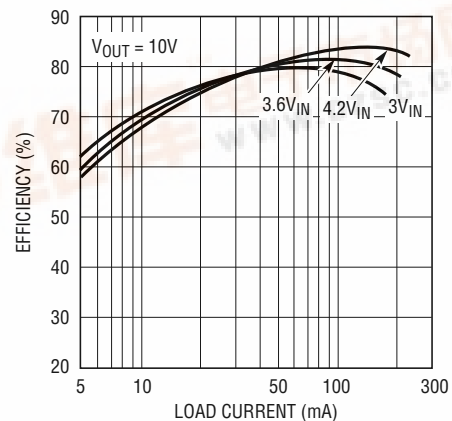

1949-1 F02

Figure 1. 3.3V to 10V/175mA DC/DC Converter

Figure 2. 3.3V to 10V Converter Efficiency



LT1949-1

ABSOLUTE MAXIMUM RATINGS

(Note 1)

V_{IN} , LBO Voltage	12V
SW Voltage	-0.4V to 30V
FB Voltage	$V_{IN} + 0.3V$
V_C Voltage	2V
LBI Voltage	$0V \leq V_{LBI} \leq 1V$
SHDN Voltage	6V
Junction Temperature	125°C
Operating Temperature Range (Note 2) ...	-40°C to 85°C
Storage Temperature	-65°C to 150°C
Lead Temperature (Soldering, 10sec)	300°C

PACKAGE/ORDER INFORMATION

	ORDER PART NUMBER
	LT1949-1EMS8
	MS8 PART MARKING
	LTQX

Consult factory for Industrial and Military grade parts.

ELECTRICAL CHARACTERISTICS

The ● denotes the specifications which apply over the full operating temperature range, otherwise specifications are at $T_A = 25^\circ\text{C}$. $V_{IN} = 2V$, $V_{SHDN} = 2V$ unless otherwise noted.

SYMBOL	PARAMETER	CONDITIONS	MIN	TYP	MAX	UNITS	
I_Q	Quiescent Current	$V_{SHDN} = 0V$	●	8	14	mA	
			●	50	80	μA	
V_{FB}	Feedback Voltage		●	1.22	1.24	1.26	V
			●	1.20	1.24	1.26	V
I_B	FB Pin Bias Current (Note 3)		●	24	150	nA	
			●	1.7	12	V	
g_m	Error Amp Transconductance	$\Delta I = 5\mu\text{A}$	●	140	280	480	μmhos
A_V	Error Amp Voltage Gain		●	700			V/V
			●	80	85		%
f_{OSC}	Switching Frequency	$V_{IN} = 2.5V$, Duty Cycle = 30%	●	0.85	1.1	1.35	MHz
			●	0.015	0.1		μA
	Shutdown Pin Current	$V_{SHDN} = V_{IN}$ $V_{SHDN} = 0V$	●	-5	-14	μA	
			●	190	200	210	mV
	LBI Threshold Voltage		●	180	200	220	mV
			●	0.15	0.25		V
	LBO Output Low	$I_{SINK} = 10\mu\text{A}$	●	20	100	nA	
	LBO Leakage Current	$V_{LBI} = 250\text{mV}$, $V_{LBO} = 5V$	●	30	120	nA	
	LBI Input Bias Current (Note 5)	$V_{LBI} = 150\text{mV}$	●	2000		V/V	
	Low-Battery Detector Gain	1M Ω Pull-Up		0.01	3	μA	
	Switch Leakage Current	$V_{SW} = 5V$	●	410	400	mV	
	Switch V_{CESAT}	$I_{SW} = 800\text{mA}$ $I_{SW} = 500\text{mA}$	●	0.08		%/V	
	Reference Line Regulation	$1.8V \leq V_{IN} \leq 12V$				V	
	SHDN Input Voltage High		●	1.4	6	V	
	SHDN Input Voltage Low		●		0.4	V	

Note 1: Absolute Maximum Ratings are those values beyond which the life of a device may be impaired.

Note 2: The LT1949-1E is guaranteed to meet performance specifications from 0°C to 70°C. Specifications over the -40°C to 85°C operating temperature range are assured by design, characterization and correlation with statistical process controls.

Note 3: Bias current flows into FB pin.

Note 4: Switch current limit guaranteed by design and/or correlation to static tests. Duty cycle affects current limit due to ramp generator.

Note 5: Bias current flows out of LBI pin.

TYPICAL PERFORMANCE CHARACTERISTICS

Oscillator Frequency

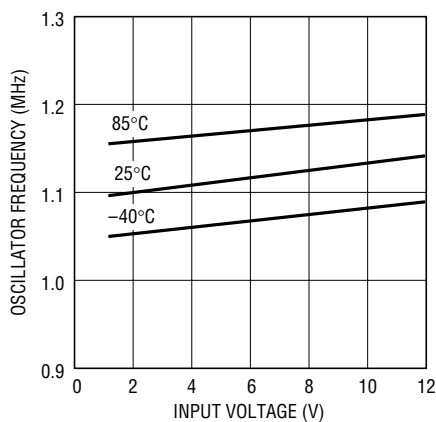

1949-1 G01

Switch Current Limit

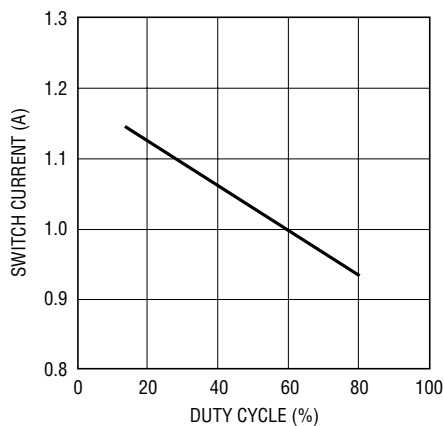

1949-1 G02

Switch Current Limit, Duty Cycle = 30%

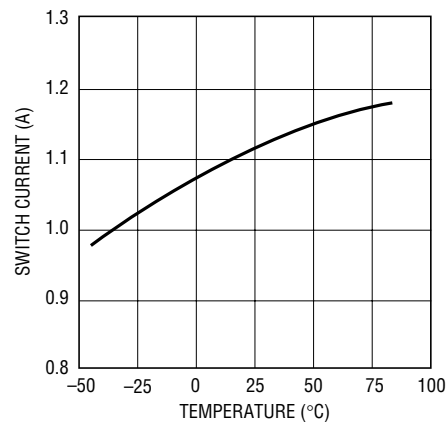

1949-1 G03

Switch Voltage Drop (V_{CESAT})

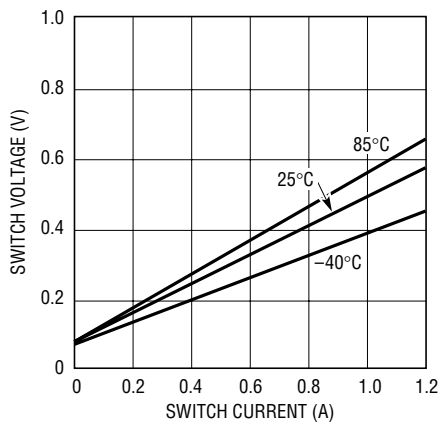

1949-1 G04

Feedback Voltage

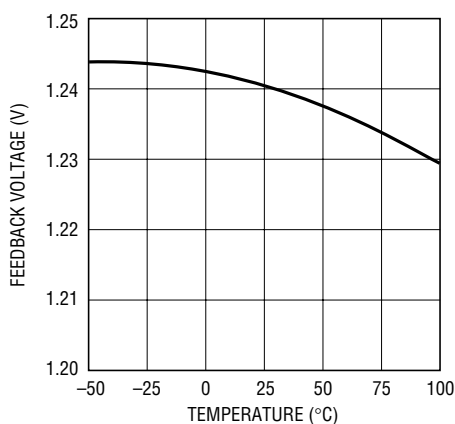

1949-1 G05

Quiescent Current, $\overline{SHDN} = 2V$

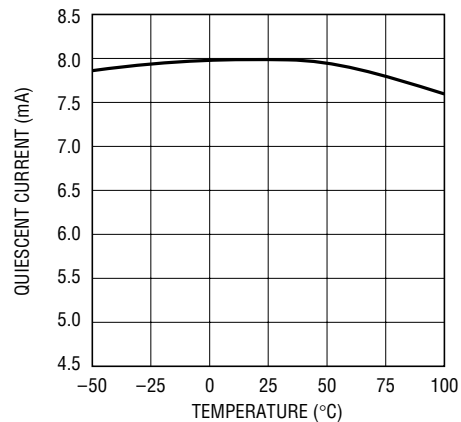

1949-1 G06

Quiescent Current, $\overline{SHDN} = 0V$

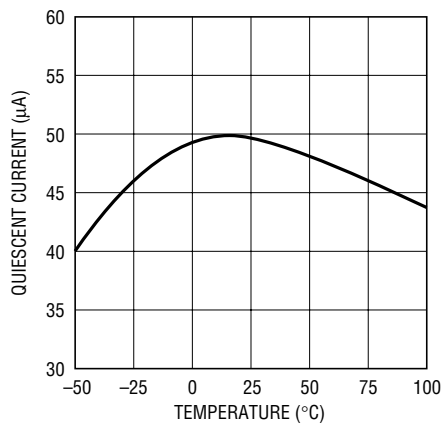

1949-1 G07

FB Pin Bias Current

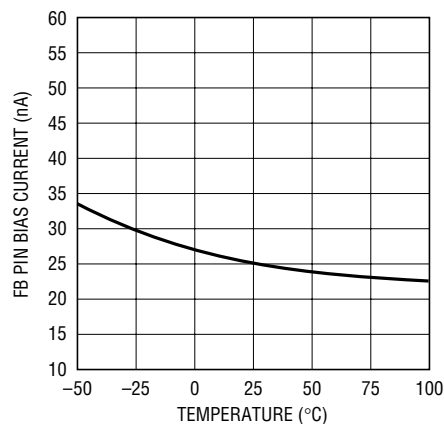

1949-1 G08

SHDN Pin Current

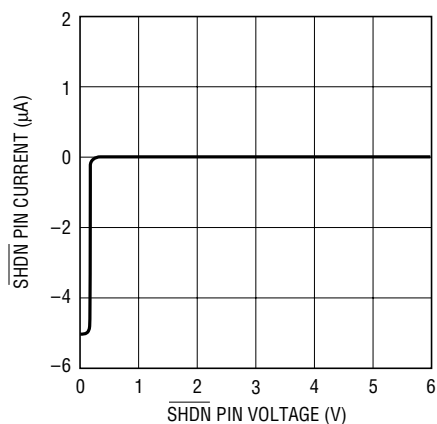

1949-1 G09

TYPICAL PERFORMANCE CHARACTERISTICS

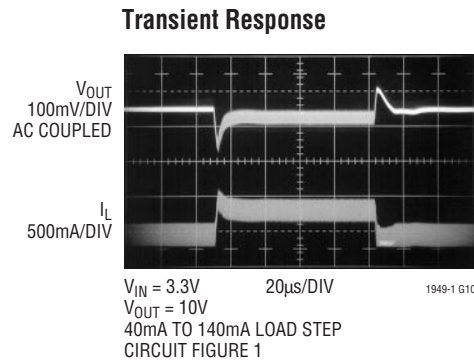

PIN FUNCTIONS

V_C (Pin 1): Compensation Pin for Error Amplifier. Connect a series RC network from this pin to ground. Typical values for compensation are a 30k/330pF combination when using ceramic output capacitors. Minimize trace area at V_C .

FB (Pin 2): Feedback Pin. Reference voltage is 1.24V. Connect resistor divider tap here. Minimize trace area at FB. Set V_{OUT} according to: $V_{OUT} = 1.24V(1 + R1/R2)$.

\overline{SHDN} (Pin 3): Shutdown. Pull this pin low for shutdown mode (only the low-battery detector remains active). Leave this pin floating or tie to a voltage between 1.4V and 6V to enable the device. \overline{SHDN} pin is logic level and need only meet the logic specification (1.4V for high, 0.4V for low).

GND (Pin 4): Ground. Connect directly to local ground plane.

SW (Pin 5): Switch Pin. Connect inductor/diode here. Minimize trace area at this pin to keep EMI down.

V_{IN} (Pin 6): Supply Pin. Must be bypassed close to the pin.

LBI (Pin 7): Low-Battery Detector Input. 200mV reference. Voltage on LBI must stay between ground and 700mV. Low-battery detector remains active in shutdown mode.

LBO (Pin 8): Low-Battery Detector Output. Open collector, can sink 10 μ A. A 1M Ω pull-up is recommended.

BLOCK DIAGRAM

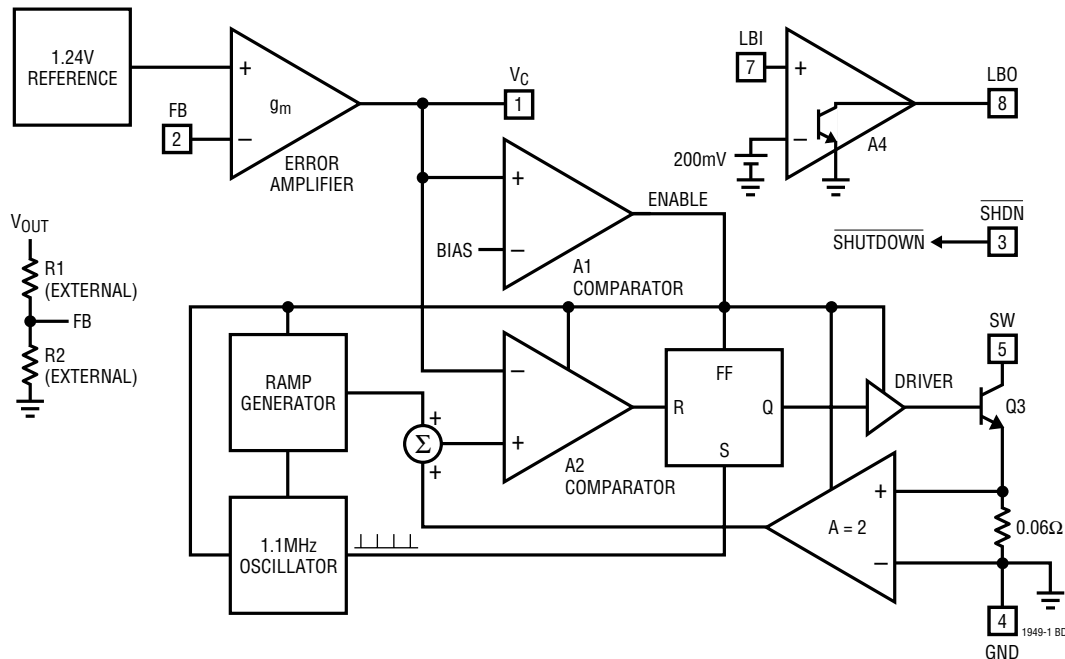

Figure 3. LT1949-1 Block Diagram

OPERATION

The LT1949-1 is a current mode, fixed frequency step-up DC/DC converter with an internal 1A NPN power transistor. Operation can best be understood by referring to the Block Diagram.

At the beginning of each oscillator cycle, the flip-flop is set and the switch is turned on. Current in the switch ramps up until the voltage at A2's positive input reaches the V_C pin voltage, causing A2's output to change state and the switch to be turned off. The signal at A2's positive input is a summation of a signal representing switch current and a ramp generator (introduced to avoid subharmonic oscillations at duty factors greater than 50%). If the load increases, V_{OUT} (and FB) will drop slightly and the error amplifier will drive V_C to a higher voltage, causing current in the switch to increase. In this way, the error amplifier drives the V_C pin to the voltage necessary to satisfy the load. Frequency compensation is provided by an external series RC network connected between the V_C pin and ground.

Layout Hints

The LT1949-1 switches current at high speed, mandating careful attention to layout for proper performance. *You will not get advertised performance with careless layouts.* Figure 4 shows recommended component placement for a boost (step-up) converter. Follow this closely in your PC layout. Note the direct path of the switching loops. Input capacitor C1 *must* be placed close (<5mm) to the IC package. As little as 10mm of wire or PC trace from C_{IN} to V_{IN} will cause problems such as inability to regulate or oscillation.

The ground terminal of output capacitor C2 should tie close to Pin 4 of the LT1949-1. Doing this reduces di/dt in the ground copper which keeps high frequency spikes to a minimum. The DC/DC converter ground should tie to the PC board ground plane at one place only, to avoid introducing di/dt in the ground plane.

OPERATION

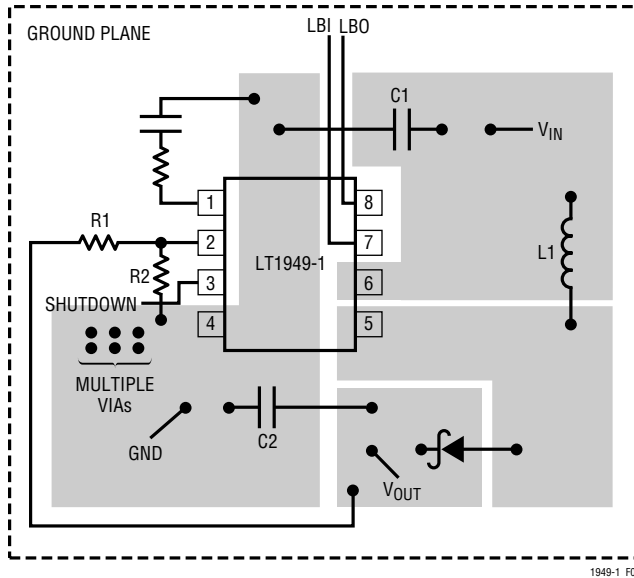

Figure 4. Recommended Component Placement for Boost Converter. Note Direct High Current Paths Using Wide PC Traces. Minimize Trace Area at Pin 1 (V_C) and Pin 2 (FB). Use Multiple Vias to Tie Pin 4 Copper to Ground Plane. Use Vias at One Location Only to Avoid Introducing Switching Currents into the Ground Plane

APPLICATIONS INFORMATION

Low-Battery Detector

The LT1949-1's low-battery detector is a simple PNP input gain stage with an open collector NPN output. The negative input of the gain stage is tied internally to a 200mV $\pm 5\%$ reference. The positive input is the LBI pin. Arrangement as a low-battery detector is straightforward.

Figure 5 details hookup. R1 and R2 need only be low enough in value so that the bias current of the LBI pin doesn't cause large errors. For R2, 49.9k is adequate. The 200mV reference can also be accessed as shown in Figure 6. The low-battery detector remains active in shutdown.

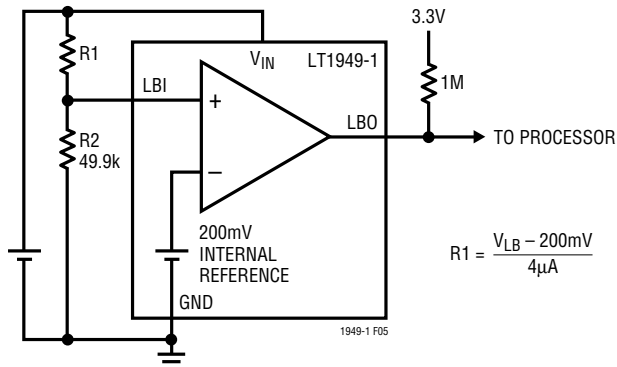

Figure 5. Setting Low-Battery Detector Trip Point

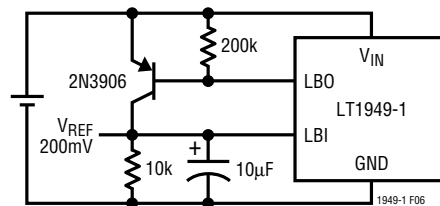
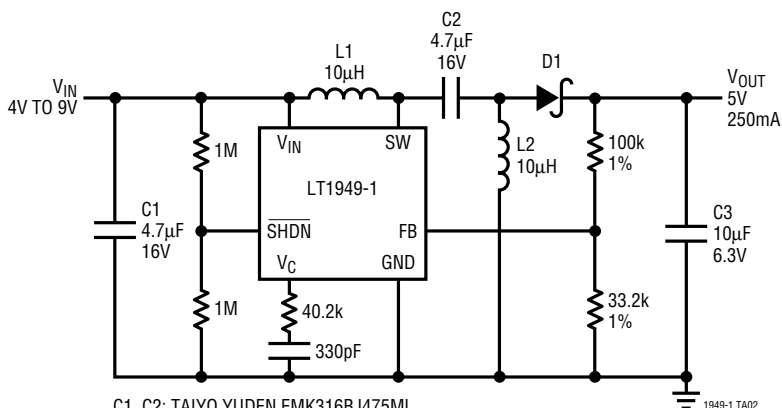

Figure 6. Accessing 200mV Reference

TYPICAL APPLICATION

4 Cell to 5V SEPIC Converter



C1, C2: TAIYO YUDEN EMK316BJ475ML
 C3: TAIYO YUDEN JMK316BJ106ML
 D1: MOTOROLA MBRM120LT3
 L1, L2: SUMIDA CR32-100KC

PACKAGE DESCRIPTION

Dimensions in inches (millimeters) unless otherwise noted.

MS8 Package 8-Lead Plastic MSOP (LTC DWG # 05-08-1660)

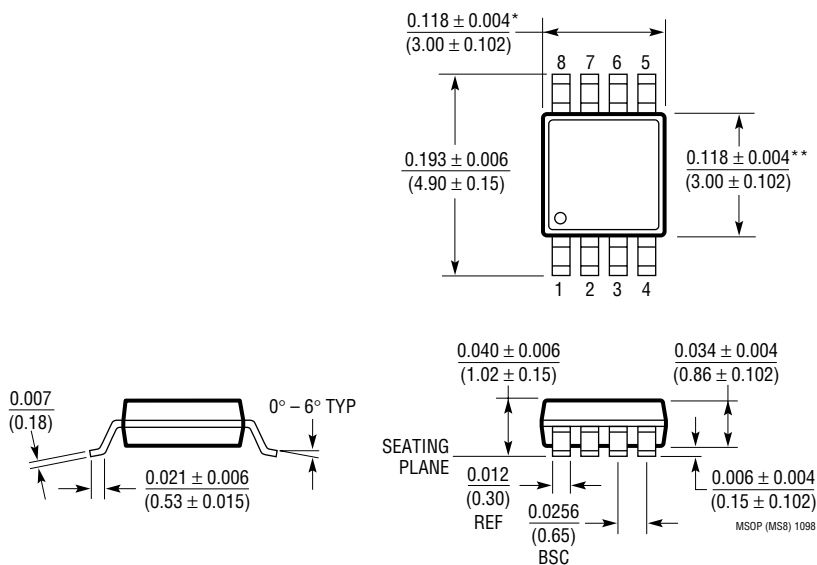

* DIMENSION DOES NOT INCLUDE MOLD FLASH, PROTRUSIONS OR GATE BURRS. MOLD FLASH, PROTRUSIONS OR GATE BURRS SHALL NOT EXCEED 0.006* (0.152mm) PER SIDE

** DIMENSION DOES NOT INCLUDE INTERLEAD FLASH OR PROTRUSIONS. INTERLEAD FLASH OR PROTRUSIONS SHALL NOT EXCEED 0.006* (0.152mm) PER SIDE

TYPICAL APPLICATION

Low Profile Triple Output LCD Bias Generator

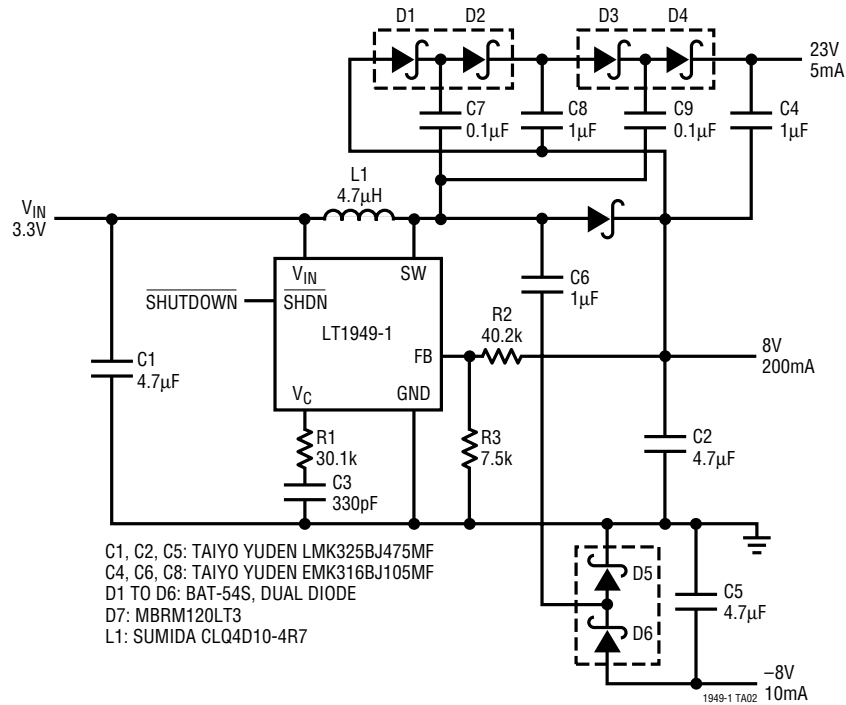

RELATED PARTS

PART NUMBER	DESCRIPTION	COMMENTS
LT1302	High Output Current Micropower DC/DC Converter	5V/600mA from 2V, 2A Internal Switch, 200µA I _Q
LT1304	2-Cell Micropower DC/DC Converter	Low-Battery Detector Active in Shutdown
LT1307B	Single Cell Micropower 600kHz PWM DC/DC Converter	3.3V at 75mA from 1 Cell, MSOP Package
LT1308B	2A 600kHz PWM DC/DC Converter	36V Switch, Fixed Frequency Operation, SO-8 and TSSOP Packages
LT1317B	Micropower, 600kHz PWM DC/DC Converter	2 Cells to 3.3V at 200mA, MSOP Package
LT1377	Monolithic 1MHz, 1.5A Switching Regulator	Regulates Positive or Negative Outputs, Ext Synchronization
LT1613	Single Cell 1.4MHz PWM DC/DC Converter	3.3V to 5V at 200mA, SOT-23 Package
LT1615	Micropower Boost Converter in SOT-23	I _Q = 20µA, <1µA in Shutdown, V _{OUT} Up to 34V
LT1930	1.2MHz Boost Converter in SOT-23	1A, 36V Internal Switching, V _{IN} = 2.6V to 16V
LT1949	600kHz, 1A Switch PWM DC/DC Converter	1A, 0.5Ω, 30V Internal Switch, 8-Lead MSOP and SO Packages