

SMD Type Transistors

Silicon PNP Epitaxia
2SA1385-Z

Features

- Low $V_{CE(sat)}$: $V_{CE(sat)} = -0.18$ V TYP.

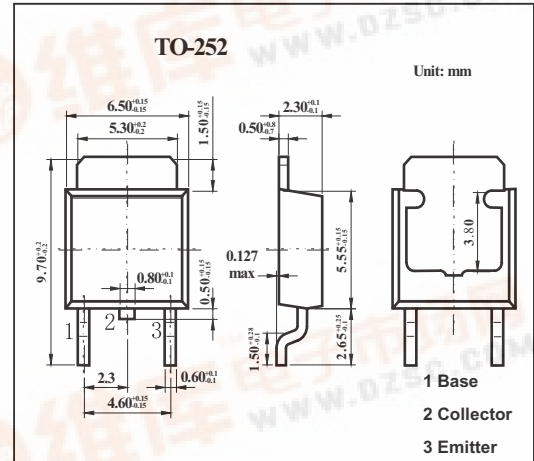

Absolute Maximum Ratings $T_a = 25^\circ\text{C}$

Parameter	Symbol	Rating	Unit
Collector-base voltage	V_{CB0}	-60	V
Collector-emitter voltage	V_{CE0}	-60	V
Emitter-base voltage	V_{EB0}	-7	V
Collector current	I_C	-5	A
Collector current pulse *	I_{CP}	-7	A
Total power dissipation	P_T	10	W
Junction temperature	T_j	150	$^\circ\text{C}$
Storage temperature	T_{stg}	-55 to +150	$^\circ\text{C}$

* $PW \leq 10\text{ms}$, duty cycle $\leq 50\%$.

Electrical Characteristics $T_a = 25^\circ\text{C}$

Parameter	Symbol	Testconditions	Min	Typ	Max	Unit
Collector cut-off current	I_{CBO}	$V_{CB} = -50$ V, $I_E = 0$			-10	μA
Emitter cut-off current	I_{EBO}	$V_{EB} = -7$ V, $I_C = 0$			-10	μA
DC current gain *	h_{FE}	$V_{CE} = -1$ V, $I_C = -2$ A	100	200	400	
Collector-emitter saturation voltage *	$V_{CE(sat)}$	$I_C = -2$ A, $I_B = -0.2$ A		-0.18	-0.3	V
Base-emitter saturation voltage *	$V_{BE(sat)}$	$I_C = -2$ A, $I_B = -0.2$ A			-1.2	V
Gain bandwidth product	f_T	$V_{CE} = -10$ V, $I_C = -0.5$ A		140		MHz
Turn-on time	t_{on}	$I_C = -2$ A, $I_{B1} = -I_{B2} = -0.2$ A, $R_L = 50\Omega$, $V_{CC} = -10$ V		0.08	1.0	μs
Storage time	t_{stg}			0.55	2.5	μs
Fall time	t_f			0.18	1.0	μs

* $PW \leq 350\mu\text{s}$, duty cycle $\leq 2\%$.

hFE Classification

Marking	M	L	K
	100~200	160~320	200~400

