

SMD Type Transistors

Silicon Transistor
2SA1400-Z

Features

- High Voltage: $V_{CE0} = -400V$
- High speed: $t_r \leq 1.0\mu s$

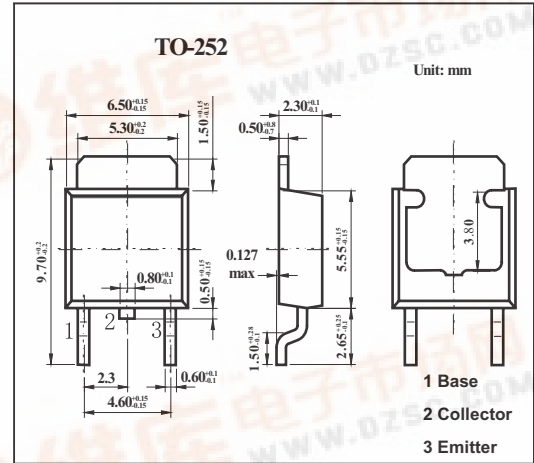

Absolute Maximum Ratings $T_a = 25^\circ C$

Parameter	Symbol	Rating	Unit
Collector to Base Voltage	V_{CB0}	-400	V
Collector to Emitter Voltage	V_{CE0}	-400	V
Emitter to Base Voltage	V_{EB0}	-7	V
Collector Current (DC)	I_C	-0.5	A
Collector Current (Pulse) *1	I_C	-1	A
Total power Dissipation ($T_a = 25^\circ C$) *2	P_T	2	W
Junction Temperature	T_j	150	$^\circ C$
Storage Temperature	T_{stg}	-55 to 150	$^\circ C$

*1 $p_w \leq 300\mu s, Duty Cycle \leq 10\%$

*2 When mounted on ceramic substrate of $7.5cm^2 \times 0.7mm$

Electrical Characteristics $T_a = 25^\circ C$

Parameter	Symbol	Test conditions	Min	Typ	Max	Unit
Collector Cutoff Current	I_{CB0}	$V_{CB} = -400V, I_E = 0$			-100	μA
Emitter Cutoff Current	I_{EB0}	$V_{EB} = -5V, I_C = 0$			-10	V
DC Current Gain*	h_{FE}	$V_{CE} = -5V, I_C = -50mA$	30		200	
Collector Saturation Voltage *	$V_{CE(sat)}$	$I_C = -100mA, I_B = -10mA$			-1	V
Base Saturation Voltage *	$V_{BE(sat)}$	$I_C = -100mA, I_B = -10mA$			-1.2	V
Turn-on Time	t_{on}	$I_C = -100mA, R_L = 1.5K\Omega$			1	μs
Storage Time	t_{stg}	$I_{B1} = -I_{B2} = -10mA, V_{CC} = -150V$			5	
Fall time	t_f	$PW \leq 50\mu s, Duty Cycle \leq 2\%$			1	

* $PW \leq 350\mu s, Duty Cycle \leq 2\%$

hFE Classification

Marking	N	M	L	K
h_{FE}	30 to 60	40 to 80	60 to 120	100 to 200

