

SMD Type Transistors

NPN Silicon Epitaxial Transistor  
2SD1899-Z

■ Features

- Low  $V_{CE(sat)}$ .
- High  $h_{FE}$ .

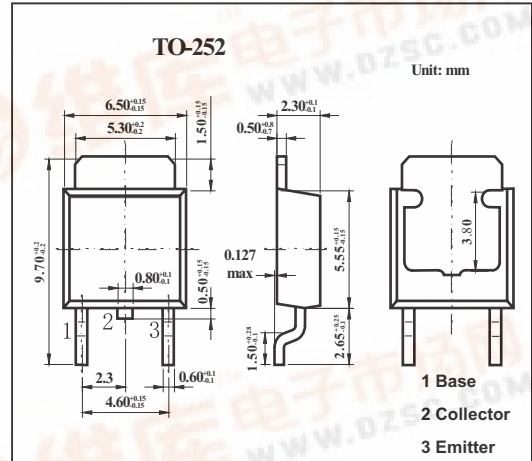

■ Absolute Maximum Ratings  $T_a = 25^\circ\text{C}$

Parameter	Symbol	Rating	Unit
Collector-base voltage	$V_{CBO}$	60	V
Collector-emitter voltage	$V_{CEO}$	60	V
Emitter-base voltage	$V_{EBO}$	7	V
Collector current (DC)	$I_C$	3	A
Collector Current (pulse) *1	$I_{CP}$	5	A
Base current	$I_B$	0.5	A
Total power dissipation $T_a = 25^\circ\text{C}$	$P_T$ *2	2	W
Total power dissipation $T_c = 25^\circ\text{C}$	$P_T$	10	W
Junction temperature	$T_j$	150	$^\circ\text{C}$
Storage temperature	$T_{stg}$	-55 to +150	$^\circ\text{C}$

\*1 Pulse Test  $PW \leq 10\text{ms}$ , Duty Cycle  $\leq 50\%$ .

\*2 Mounted on ceramic substrate of  $7.5\text{mm}^2 \times 0.7\text{mm}$



## 2SD1899-Z

## ■ Electrical Characteristics Ta = 25°C

Parameter	Symbol	Testconditons	Min	Typ	Max	Unit
Collector cutoff current	IcBO	V <sub>CB</sub> = 60 V, I <sub>E</sub> = 0			10	μs
Emitter cutoff current	I <sub>EBO</sub>	V <sub>EB</sub> = 7 V, I <sub>C</sub> = 0			10	μA
DC current gain *	h <sub>FE</sub>	V <sub>CE</sub> = 2V, I <sub>C</sub> = 0.2 A	60			
		V <sub>CE</sub> = 2V, I <sub>C</sub> = 0.6 A	100		400	
		V <sub>CE</sub> = 2V, I <sub>C</sub> = 2.0 A	50			
Collector saturation voltage *	V <sub>CE(sat)</sub>	I <sub>C</sub> = 1.5 A, I <sub>B</sub> = 0.15 A		0.14	0.25	V
Base saturation voltage *	V <sub>BE(sat)</sub>	I <sub>C</sub> = 1.5 A, I <sub>B</sub> = 0.15 A		0.93	1.2	V
Gain bandwidth product	f <sub>T</sub>	V <sub>CE</sub> = 5 V, I <sub>E</sub> = -1.5 A		120		MHz
Output capacitance	C <sub>ob</sub>	V <sub>CB</sub> = 10 V, I <sub>E</sub> = 0, f = 1.0 MHz		30		pF
Turn-on time	t <sub>on</sub>	I <sub>C</sub> = 1 A, V <sub>CC</sub> = 10 V I <sub>B1</sub> = -I <sub>B2</sub> = 0.1 A		0.15	0.5	μs
Storage time	t <sub>stg</sub>			0.75	2	μs
Fall time	t <sub>f</sub>		R <sub>L</sub> = 10Ω		0.2	0.5

\* Pulsed: PW ≤ 350 μs, duty cycle ≤ 2%

## ■ hFE Classification

Marking	M	L	K
hFE	100~200	160~320	200~400