

SMD Type Diodes

Silicon Epitaxial Planar Diode

1SV310

■ Features

- High Capacitance Ratio: $C_{1V}/C_{4V}=2.1$ (Typ.)
- Low Series Resistance: $r_s=0.28 \Omega$ (Typ.)

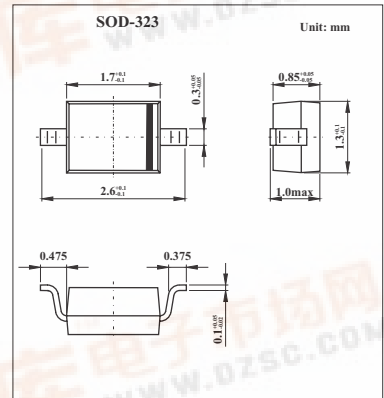

■ Absolute Maximum Ratings $T_a = 25^\circ C$

Parameter	Symbol	Value	Unit
Reverse Voltage	V_R	10	V
Junction Temperature	T_j	125	$^\circ C$
Storage Temperature Range	T_{stg}	-55 to +125	$^\circ C$

■ Electrical Characteristics $T_a = 25^\circ C$

Parameter	Symbol	Conditions	Min	Typ	Max	Unit
Reverse Voltage	V_R	$I_R = 1 \mu A$	10			V
Reverse Current	I_R	$V_R = 10 V$			3	nA
Capacitance	C_{1V}	$f = 1 MHz; V_R = 1 V$	9.7		11.1	pF
	C_{4V}	$f = 1 MHz; V_R = 4 V$	4.45		5.45	
Capacitance Ratio	C_{1V}/C_{4V}		1.8	2.1		
Series Resistance	r_s	$V_R = 1V, f = 470 MHz$		0.28	0.4	Ω

■ Marking

Marking	V1
---------	----