

SMD Type Transistors

High Voltage Switching Transistor  
2SC5161

■ Features

- Low  $V_{CE(sat)}$ .  
 $V_{CE(sat)} = 0.15V$  (Typ.),  $I_C / I_B = 1A / 0.2A$
- High breakdown voltage.  $V_{CEO} = 400V$
- Fast switching.  $t_r = 1.0\mu s$ ,  $I_C = 0.8A$
- NPN silicon transistor

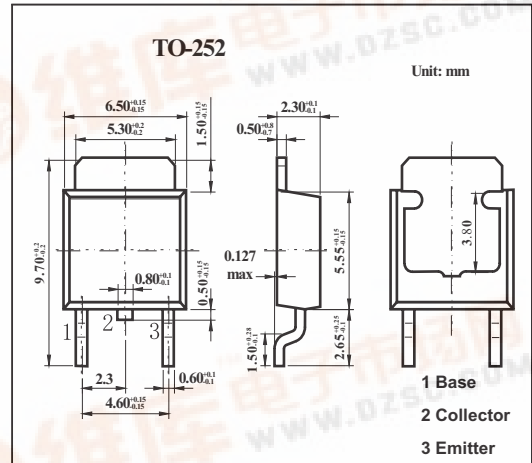

■ Absolute Maximum Ratings  $T_a = 25^\circ C$

Parameter	Symbol	Rating	Unit
Collector to base voltage	$V_{CBO}$	400	V
Collector to emitter voltage	$V_{CES}$	400	V
Emitter to base voltage	$V_{EBO}$	7	V
Peak collector current *	$I_{CP}$	4	A(Puse)
Collector current	$I_C$	2	A(DC)
Collector power dissipation	$P_C$	$T_c = 25^\circ C$	10
		$T_a = 25^\circ C$	1
Junction temperature	$T_j$	150	$^\circ C$
Storage temperature	$T_{stg}$	-55 to +150	$^\circ C$

\* Single pulse  $p_w = 10ms$

## 2SC5161

## ■ Electrical Characteristics Ta = 25°C

Parameter	Symbol	Testconditons	Min	Typ	Max	Unit
Collector-base breakdown voltage	BVCBO	Ic=50μA	400			V
collector-emitter breakdown voltage	BVCEO	Ic=1mA	400			V
collector-emitter voltage	VCEO(SUS)	Ic=1.0A, IB1=0.1A, L=1mH	400			V
Emitter-base breakdown voltage	BVEBO	IE=50μA	7			V
colleotr cutoff current	ICBO	VCB=400V			10	μA
Emitter cutoff current	IEBO	VEB=7V			10	μA
Collector to emitter saturation voltage	VCE(sat)	Ic/IB=1A/0.2A			1	V
Base to emitter saturation voltage	VBE(sat)	Ic/IB=1A/0.2A			1.5	V
DC current transfer ratio	hFE	VCE=5V, Ic=0.1A	25		50	
Transition frequency	fr	VCE=10V, IE=-0.1A, f=5MHz		10		MHz
Output capacitance	cob	VCB=10V, IE=0A, f=1MHz		30		pF
Turn-on time	ton	Ic=0.8A, RL=250Ω			1	μs
Storage time	tstg	IB1=-IB2=0.08A			2.5	μs
Fall time	tr	VCC=200V			1	μs

## ■ hFE Classification

Item	B
hFE	25 to 50