

SMD Type Transistors

PNP Silicon Epitaxial Transistor
2SA812

■ Features

- High DC Current Gain: $hFE = 200$ TYP. ($V_{CE} = -6.0$ V, $I_C = -1.0$ mA)
- High Voltage: $V_{CEO} = -50$ V

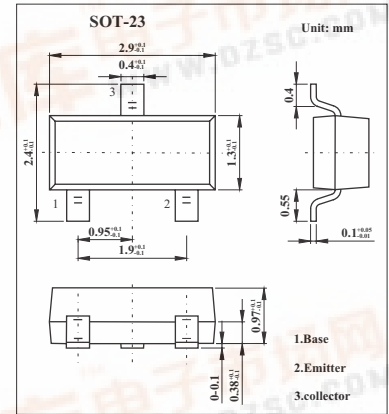

■ Absolute Maximum Ratings $T_a = 25^\circ C$

Parameter	Symbol	Rating	Unit
Collector to base voltage	V_{CBO}	-60	V
Collector to emitter voltage	V_{CEO}	-50	V
Emitter to base voltage	V_{EBO}	-5.0	V
Collector current (DC)	I_C	-100	mA
power dissipation	P_C	200	mW
Junction temperature	T_j	150	$^\circ C$
Storage temperature range	T_{stg}	-55 to +150	$^\circ C$

■ Electrical Characteristics $T_a = 25^\circ C$

Parameter	Symbol	Testconditons	Min	Typ	Max	Unit
Collector cutoff current	I_{CBO}	$V_{CB} = -60$ V, $I_E = 0$ A			-0.1	μA
Emitter cutoff current	I_{EBO}	$V_{EB} = -5.0$ V, $I_C = 0$ A			-0.1	μA
DC current gain *	hFE	$V_{CE} = -6.0$ V, $I_C = -1.0$ mA	90	200	600	
Collector saturation voltage	$V_{CE(sat)}$	$I_C = -100$ mA, $I_B = -10$ mA		-0.18	-0.3	V
Base to emitter voltage	V_{BE}	$V_{CE} = 6.0$ V, $I_C = -1.0$ mA	-0.58	-0.62	-0.68	V
Output capacitance	C_{ob}	$V_{CE} = -10$ V, $I_E = 0$ A, $f = 1.0$ MHz		4.5		pF
Transition frequency	f_T	$V_{CE} = -6.0$ V, $I_E = 10$ mA		180		MHz

* Pulsed: $PW \leq 350 \mu s$, Duty Cycle $\leq 2\%$

■ hFE Classification

Marking	M4	M5	M6	M7
hFE	90~180	135~270	200~400	300~600



2SA812

■ Typical Characteristics

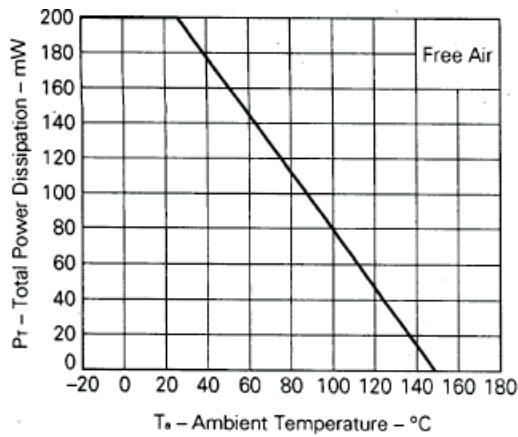

Fig.1 Total Power Dissipation vs. Ambient Temperature

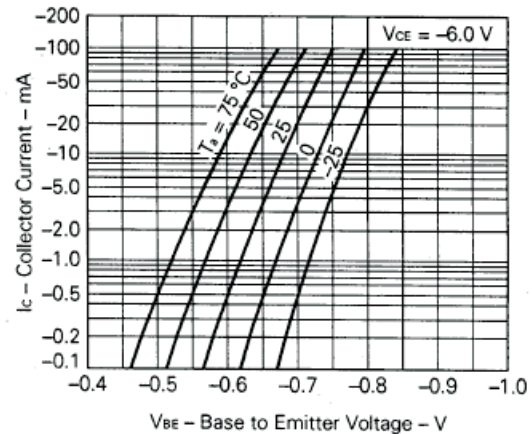

Fig.2 Collector Current vs. Base to Emitter Voltage

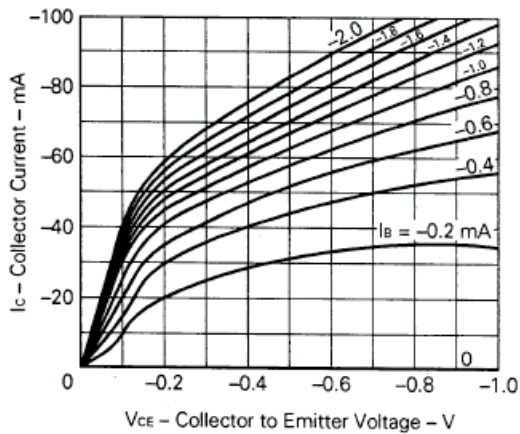

Fig.3 Collector Current vs. Collector to Emitter Voltage

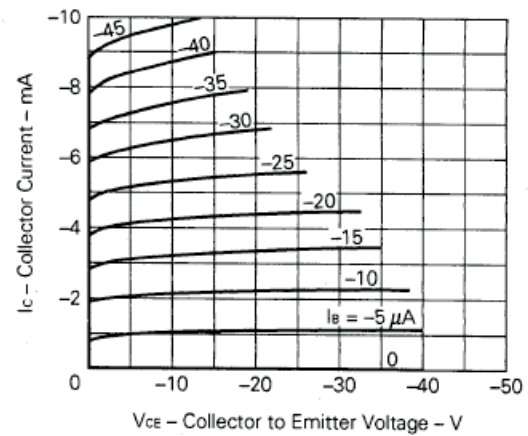

Fig.4 Collector Current vs. Collector to Emitter Voltage

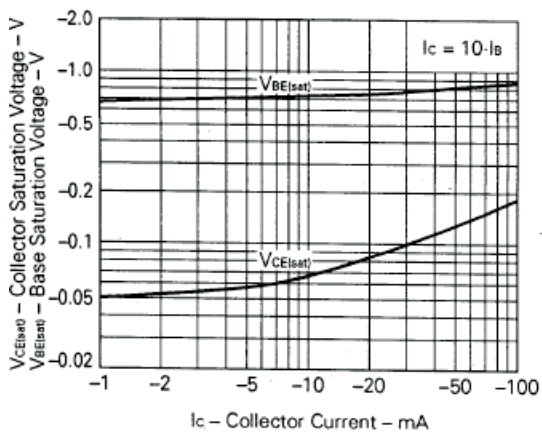

Fig.5 Base and Collector Saturation Voltage vs. Collector Current

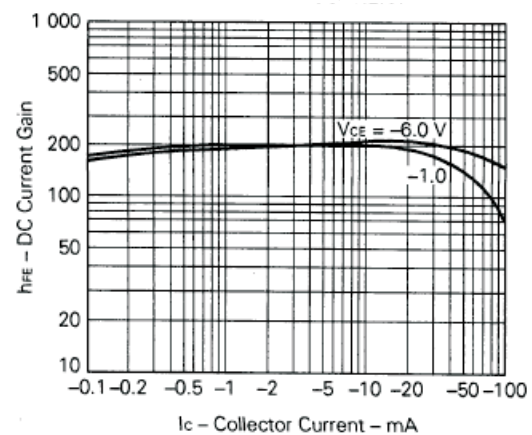

Fig.6 DC Current Gain vs. Collector Current