

SMD Type MOSFET

MOS Field Effect Transistor
2SK3900

■ Features

- Low On-state resistance
 $R_{DS(on)1} = 8.0m\Omega \text{ MAX. (} V_{GS} = 10 \text{ V, } I_D = 41\text{A)}$
 $R_{DS(on)2} = 10 \text{ m}\Omega \text{ MAX. (} V_{GS} = 4.5 \text{ V, } I_D = 41 \text{ A)}$
- Low C_{iss} : $C_{iss} = 3500 \text{ pF TYP.}$

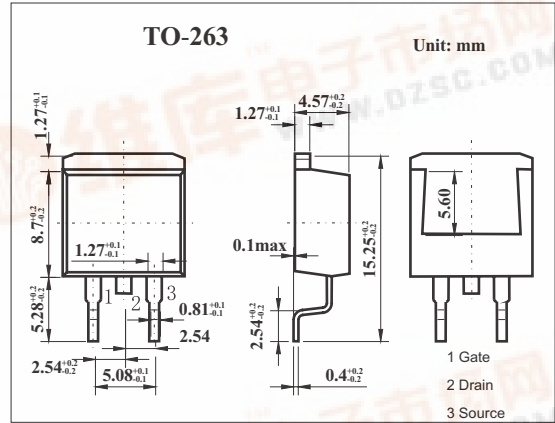

■ Absolute Maximum Ratings $T_a = 25^\circ\text{C}$

Parameter	Symbol	Rating	Unit
Drain to source voltage	V_{DS}	60	V
Gate to source voltage	V_{GS}	± 20	V
Drain current	I_D	± 82	A
	I_{dp}^*	± 246	A
Power dissipation	P_D	$T_A=25^\circ\text{C}$	1.5
		$T_C=25^\circ\text{C}$	104
Channel temperature	T_{ch}	150	$^\circ\text{C}$
Storage temperature	T_{stg}	-55 to +150	$^\circ\text{C}$

* $PW \leq 10 \mu\text{s}$, Duty Cycle $\leq 1\%$

■ Electrical Characteristics $T_a = 25^\circ\text{C}$

Parameter	Symbol	Testconditions	Min	Typ	Max	Unit
Drain cut-off current	I_{DSS}	$V_{DS}=60\text{V}, V_{GS}=0$			10	μA
Gate leakage current	I_{GSS}	$V_{GS} = \pm 20\text{V}, V_{DS}=0$			± 10	μA
Gate cut off voltage	$V_{GS(off)}$	$V_{DS}=10\text{V}, I_D=1\text{mA}$	1.5	2.0	2.5	V
Forward transfer admittance	$ Y_{fs} $	$V_{DS}=10\text{V}, I_D=41\text{A}$	28.1	56		S
Drain to source on-state resistance	$R_{DS(on)1}$	$V_{GS}=10\text{V}, I_D=41\text{A}$		6.3	8.0	$\text{m}\Omega$
	$R_{DS(on)2}$	$V_{GS}=4.5\text{V}, I_D=41\text{A}$		7.4	10	$\text{m}\Omega$
Input capacitance	C_{iss}			3500		pF
Output capacitance	C_{oss}	$V_{DS}=10\text{V}, V_{GS}=0, f=1\text{MHz}$		660		pF
Reverse transfer capacitance	C_{rss}			240		pF
Turn-on delay time	t_{on}			18		ns
Rise time	t_r	$I_D=41\text{A}, V_{GS(on)}=10\text{V}, R_G=0\Omega, V_{DD}=30\text{V}$		11		ns
Turn-off delay time	t_{off}			62		ns
Fall time	t_f			5.5		ns
Total Gate Charge	Q_G		$V_{DD} = 48\text{V}$		65.5	
Gate to Source Charge	Q_{GS}	$V_{GS} = 10 \text{ V}$		11.5		nC
Gate to Drain Charge	Q_{GD}	$I_D = 82\text{A}$		16.5		nC

