

SMD Type Transistors

Silicon PNP Epitaxial Planar Type
2SB1643

Features

- High collector to emitter V_{CE0} .
- High collector power dissipation P_c .

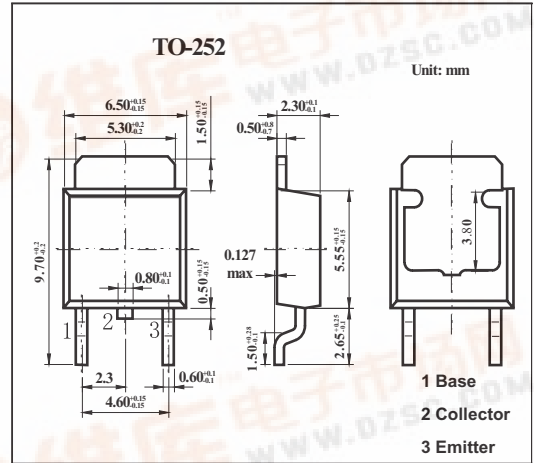

Absolute Maximum Ratings $T_a = 25^\circ\text{C}$

Parameter	Symbol	Rating	Unit
Collector-base voltage	V_{CB0}	-60	V
Collector-emitter voltage	V_{CE0}	-60	V
Emitter-base voltage	V_{EB0}	-6	V
Collector current	I_c	-3	A
Peak collector current	I_{CP}	-6	A
Base current	I_B	-1	A
Collector power dissipation	P_c	$T_c = 25^\circ\text{C}$	40
		$T_a = 25^\circ\text{C}$	1.3
Junction temperature	T_j	150	$^\circ\text{C}$
Storage temperature	T_{stg}	-55 to +150	$^\circ\text{C}$

Electrical Characteristics $T_a = 25^\circ\text{C}$

Parameter	Symbol	Test conditions	Min	Typ	Max	Unit
Collector-base cutoff current	I_{CBO}	$V_{CB} = -60\text{ V}, I_E = 0$			-100	μA
Collector-emitter cutoff current	I_{CEO}	$V_{EB} = -40\text{ V}, I_c = 0$			-100	μA
Emitter-base cutoff current	I_{EBO}	$V_{EB} = -6\text{ V}, I_c = 0$			-100	μA
Collector-emitter voltage	V_{CE0}	$I_c = -25\text{ mA}, I_B = 0$	-60			V
Forward current transfer ratio	h_{FE}	$V_{CE} = -4\text{ V}, I_c = -0.5\text{ A}$	300		700	
Collector-emitter saturation voltage	$V_{CE(sat)}$	$I_c = -2\text{ A}, I_B = -0.05\text{ A}$			-1	V
Transition frequency	f_T	$V_{CE} = -12\text{ V}, I_c = -0.2\text{ A}, f = 10\text{ MHz}$		30		MHz

h_{FE} Classification

Rank	Q	P
h_{FE}	300~500	400~700

