

SMD Type

Transistors

NPN Silicon Planar Medium Power High Gain Transistor
FZT789A

■ Features

- Low equivalent on-resistance; $R_{CE(sat)}$ 93mΩ at 3A.
- Gain of 300 at $I_C=2$ Amps and Very low saturation voltage.

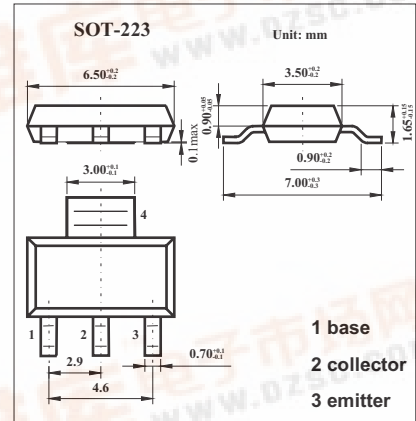

■ Absolute Maximum Ratings $T_a = 25^\circ\text{C}$

Parameter	Symbol	Rating	Unit
Collector-base voltage	V_{CB0}	-25	V
Collector-emitter voltage	V_{CE0}	-25	V
Emitter-base voltage	V_{EB0}	-5	V
Continuous collector current	I_{CM}	-6	A
Peak pulse current	I_C	-3	A
Power dissipation	P_{tot}	2	W
Operating and storage temperature range	T_j, T_{stg}	-55 to +150	$^\circ\text{C}$

FZT789A

■ Electrical Characteristics Ta = 25°C

Parameter	Symbol	Testconditions	Min	Typ	Max	Unit
Breakdown Voltages	V _{(BR)CBO}	I _C =-100μA	-25	-40		V
Breakdown Voltages *	V _{(BR)CEO}	I _C =-10mA	-25	-35		V
Breakdown Voltages	V _{(BR)EBO}	I _E =-100μA	-5	-8.5		V
Collector Cut-Off Current	I _{CBO}	V _{CB} =-15V V _{CB} =-15V, Ta = 100°C			-0.1 10	μA
Emitter Cut-Off Current	I _{EBO}	V _{EB} =-4V			-0.1	μA
Saturation Voltages *	V _{CE(sat)}	I _C =-1A, I _B =-10mA I _C =-2A, I _B =-20mA I _C =-3A, I _B =-100mA		-0.15 -0.30 -0.30	-0.25 -0.45 -0.50	V
Saturation Voltages *	V _{BE(sat)}	I _C =-1A, I _B =-10mA		-0.8	-1.0	V
Base-Emitter Turn-On Voltage *	V _{BE(on)}	I _C =-1A, V _{CE} =-2V		-0.8		V
Static Forward Current Transfer Ratio	h _{FE}	I _C =-10mA, V _{CE} =-2V	300		800	
		I _C =-1A, V _{CE} =-2V*	250			
		I _C =-2A, V _{CE} =-2V*	200			
		I _C =-6A, V _{CE} =-2V*	100			
Transitional frequency	f _T	I _C =-50mA, V _{CE} =-5V, f=50MHz	100			MHz
Input capacitance	C _{ibo}	V _{EB} =-0.5V, f=1MHz		225		pF
Output capacitance	C _{obo}	V _{CB} =-10V, f=1MHz		25		pF
Turn-on time	t _(on)	I _C =-500mA, V _{CC} =-10V		35		ns
Turn-off time	t _(off)	I _{B1} =I _{B2} =-50mA		400		ns

* Pulse test: t_p = 300 μs; d ≤ 0.02.

■ Marking

Marking	FZT789A
---------	---------